

Education of an architect : a point of view.

An exhibition by the Cooper Union School of Art & Architecture at the Museum of Modern Art, New York City, November 1971

Date

1971

Publisher

[publisher not identified]

Exhibition URL

www.moma.org/calendar/exhibitions/2648

The Museum of Modern Art's exhibition history—from our founding in 1929 to the present—is available online. It includes exhibition catalogues, primary documents, installation views, and an index of participating artists.

EDUCATION OF AN ARCHITECT: A POINT OF VIEW. AN EXHIBITION BY THE COOPER UNION SCHOOL OF ART & ARCHITECTURE AT THE MUSEUM OF MODERN ART, NEW YORK CITY, NOVEMBER 1971. THIS BOOK AND THE EXHIBITION ARE CO-SPONSORED BY THE ARCHITECTURAL LEAGUE OF NEW YORK AND THE DEPARTMENT OF ARCHITECTURE AND DESIGN OF THE MUSEUM OF MODERN ART UNDER AN INITIATING GRANT FROM THE GRAHAM FOUNDATION FOR ADVANCED STUDIES IN THE FINE ARTS.





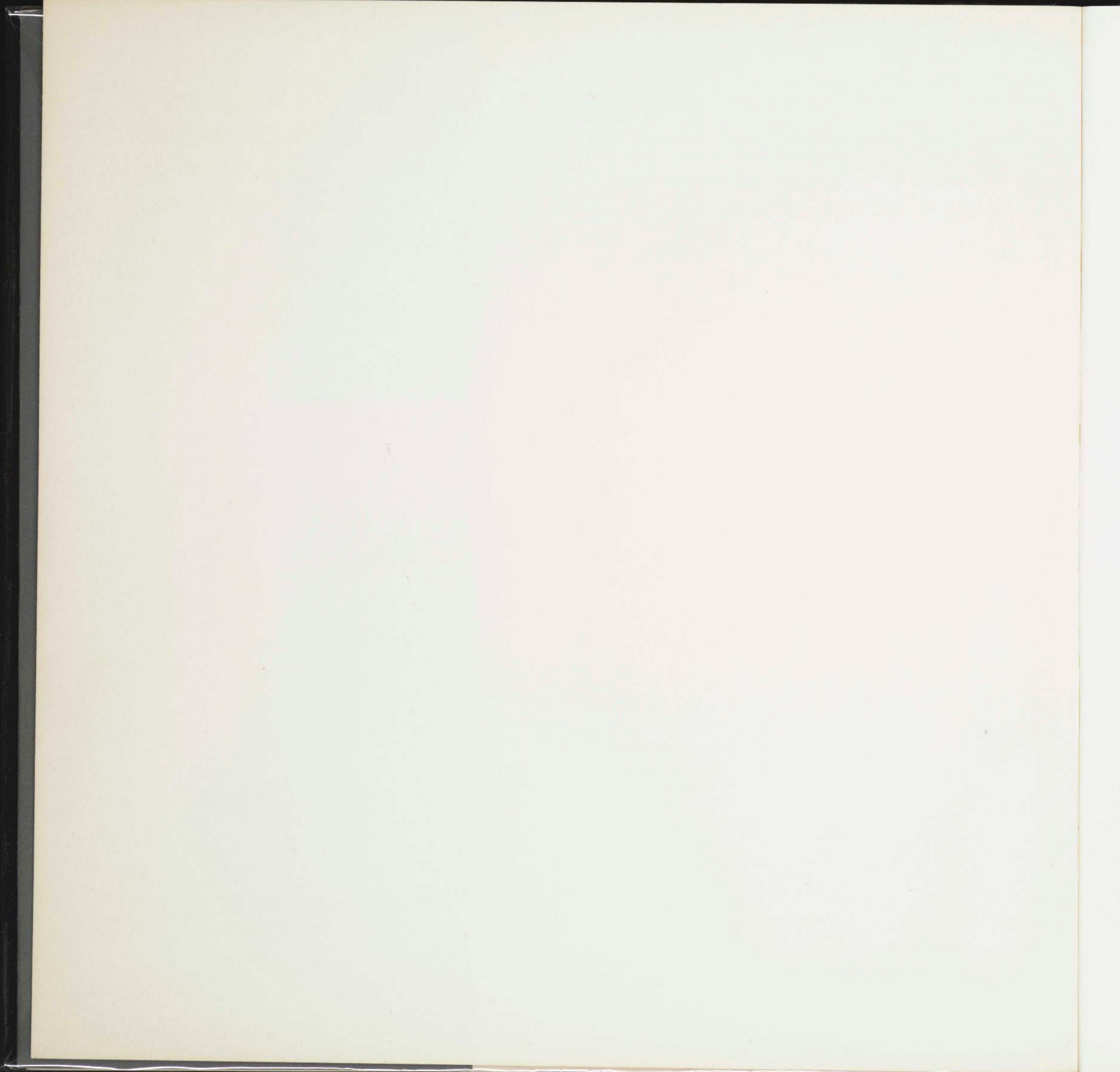

EDUCATION OF AN ARCHITECT: A POINT OF VIEW. AN EXHIBITION BY THE COOPER UNION SCHOOL OF ART & ARCHITECTURE AT THE MUSEUM OF MODERN ART, NEW YORK CITY, NOVEMBER 1971. THIS BOOK AND THE EXHIBITION ARE CO-SPONSORED BY THE ARCHITECTURAL LEAGUE OF NEW YORK AND THE DEPARTMENT OF ARCHITECTURE AND DESIGN OF THE MUSEUM OF MODERN ART UNDER AN INITIATING GRANT FROM THE GRAHAM FOUNDATION FOR ADVANCED STUDIES IN THE FINE ARTS.

ACKNOWLEDGEMENTS. May I take this opportunity to express my gratitude to the many who have contributed their time and energy, as well as financial support, to our exhibition at the Museum of Modern Art and the publication of this book. The listing of friends who gave beyond the call of duty is in alphabetical order, with three exceptions: John Entenza, Director of The Graham Foundation for Advanced Studies in the Fine Arts, whose contributions to the enhancement of our man-made world are well known to us all and cannot be enumerated within these pages. John Hejduk, Chairman of The Cooper Union Department of Architecture, whose commitment to excellence of form and ability to pass this standard on to his students are demonstrated in the work on exhibition and in the pages of this book. The Faculty of the Department of Architecture, whose point of view and commitment to architecture provide the necessary catalyst to the educational process. Paul Amatuzzo, Roger Canon, Arthur Drexler, Peter Eisenman, Carl Fischer, Ulrich Franzen, Melvyn Kaufman, Warren Piepke, George Raustiala, Arthur Rosenblatt, Kenneth Schiano, Elizabeth Shaw, Robert Slutzky, John F. White, Trustees of The Architectural League of New York, Trustees of The Cooper Union, Trustees of The Graham Foundation. *George Sadek/Dean*

TRUSTEES OF THE COOPER UNION. Clarence F. Michalis, *Chairman* / Arthur A. Houghton Jr. / Hoyt Ammidon / Robert V. Lindsay / Irwin S. Chanin / Nicholas M. Molnar / Richard R. Harshman / Bernard Levine / Albert Nerken / Frank J. Waehler / Carroll L. Wainwright, Jr.

THE SCHOOL OF ART AND ARCHITECTURE. John F. White, *President* / George Sadek, *Dean* / John Hejduk, *Chairman of the Department of Architecture* / Esmond Shaw, *Dean Emeritus*.

FOR JOHN ENTENZA.

1875

1876

1877

1878

1879

1880

1881

1882

1883

1884

1885

1886

1887

1888

1889

1890

1891

1892

1893

1894

1895

1896

1897

1898

1899

1900

1901

1902

1903

1904

1905

1906

1907

1908

1909

1910

1911

1912

1913

1914

1915

1916

1917

1918

1919

1920

INTRODUCTION The documentation, in book form as well as in an exhibition, of the work of a school of architecture is in itself a singular event. An occasion proclaiming a sound program while displaying the solid achievements of its students, accomplished during a decade of upheaval and chaos in academic as well as social values, stands out in stark contrast to the curriculum confusion and the shattered careers of so many young architects at other institutions. A look at the work of the Cooper school produces compelling evidence that this unique situation is not an inexplicable accident, but rather a situation engineered by a group of committed architect-theoreticians amply reinforced by the hard work of student architects. The concept of the curriculum structure at Cooper Union is twofold. Firstly, the formative years of the students are devoted to a series of exercises, severely limited in scope, channeling the fledgling architect's development to in-depth explorations of fundamental problems of structure and space manipulation. Secondly, the shape of the exercises is based on the visual discoveries of Cubism and Neo-plasticism, the very discoveries from which Le Corbusier and the other Paris-oriented early masters constructed their plastic and spatial language. This language was as revolutionary then as it is today, and its promise lies still unfulfilled. As Harold Rosenberg has observed, "Cubism and Futurism wrenched visual perception out of the fixities of the bucolic and the ideal, which had been the province of the Academy into the big city and its rhythms. Forms were developed to embody the simultaneity of events and the superimpositions of segments of time and place upon one another characteristic of the new pace of life. Hints were given of systems shared equally by the mind and objective reality." The student then is immediately engaged in the concrete task of fitting and sizing materials while addressing himself to visual discoveries that lie at the foundation of Modern Architecture. It is clear from the unique projects that are eventually produced that the student has acquired an understanding and love for the process of building while comprehending historical sources that nourish his first attempts at plastic and spatial creation. As a result of the non-verbal historical research, we are indebted to the Cooper Union students for their revealing studies in model form of Corbusier's pivotal designs, translating the complex forms into accessible proposals. At a fully developed level the same depth of inquiry, using a trained eye without recourse to irrelevant 'meaning', is demonstrated in the well known study by Colin Rowe and Robert Slutzky on phenomenal and literal transparency first published in *Perspecta*. The eloquence of their essay stems from its translation of visual perception into verbal information, an all too rare gift among architectural historians and teachers, but one which is characteristic of the Cooper Union approach. John Hejduk's controversial and paradoxical charge to his students to attempt the design of a building in the framework of Juan Gris' intentions demonstrates the visual and historical scholarship by which the student is surrounded. As a result it is the trained, visual sensibility which sets the student architect at the Cooper Union apart from his peers. In the context of the current situation in architecture, torn between rhetorical gestures in the area of social relevance on one hand and the anti-architecture movement employing the neo-commercial imagery of the allegedly real world on the other, the work at Cooper Union can be described as out of sequence. Nonetheless, it is the revolutionary work of the early Twenties, focused on Cubism, Neo-plasticism, Dada, and Constructivism—upholding the promise of new life-style options—with which the developments at Cooper Union have reestablished contact. This reawakened interest of the possibility of new connections between eye and mind is, of course, wholly rejected by the new conservatism in architecture as exemplified by Vincent Scully and others who are exhorting us toward reconciliation with an existing world. Only time can judge the impact of this book and its proposals, but one must salute a movement that treads where others fear to go for it may be the footprint of the future.

Ulrich Franzen

Faint, illegible text, possibly bleed-through from the reverse side of the page. The text is arranged in several columns and appears to be a formal document or report.

THE NINE-SQUARE PROBLEM. The Nine-Square problem is used as a pedagogical tool in the introduction of architecture to new students. Working within this problem the student begins to discover and understand the elements of architecture. Grid, frame, post, beam, panel, center, periphery, field, edge, line, plane, volume, extension, compression, tension, shear, etc. The student begins to probe the meaning of plan, elevation, section, and details. He learns to draw. He begins to comprehend the relationships between two-dimensional drawings, axonometric projections, and three-dimensional (model) form. The student studies and draws his scheme in plan and in axonometric, and searches out the three-dimensional implications in the model. An understanding of the elements is revealed—an idea of fabrication emerges. *John Hejduk*

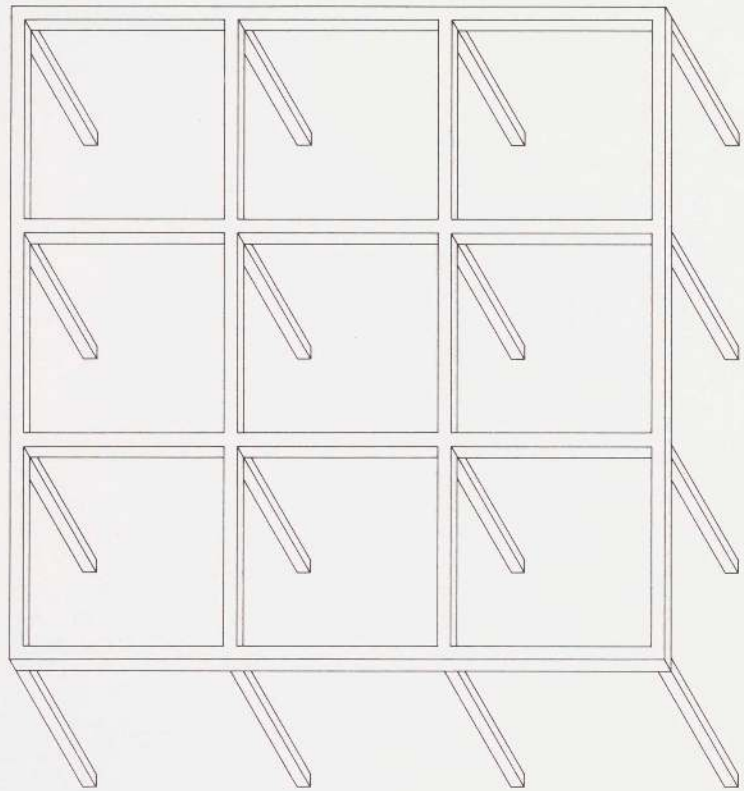

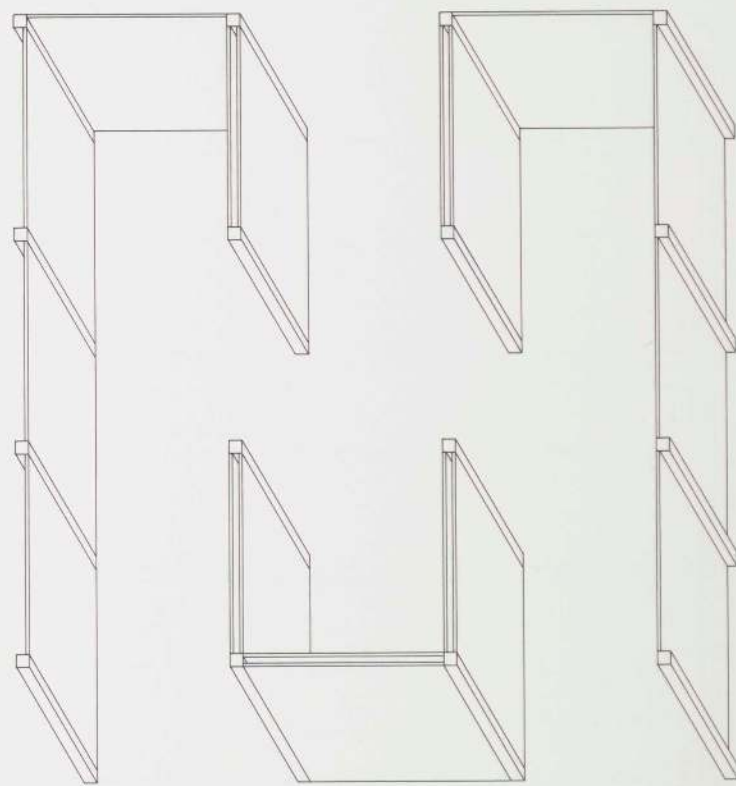
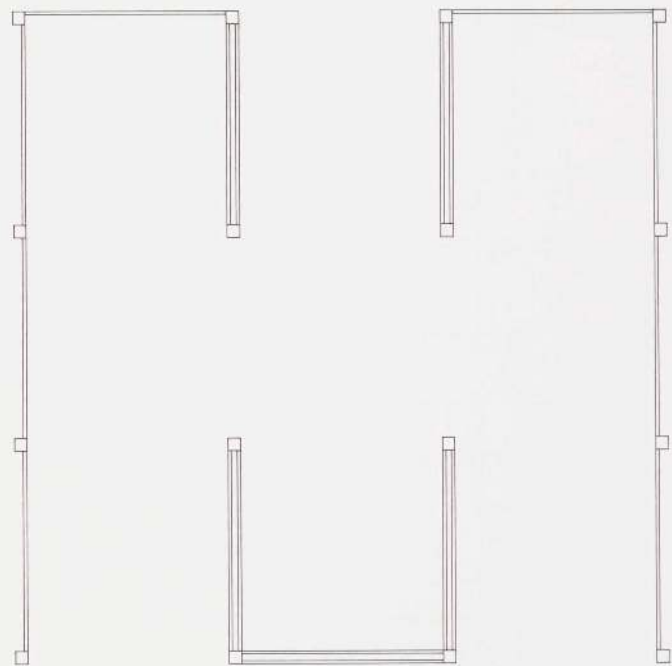

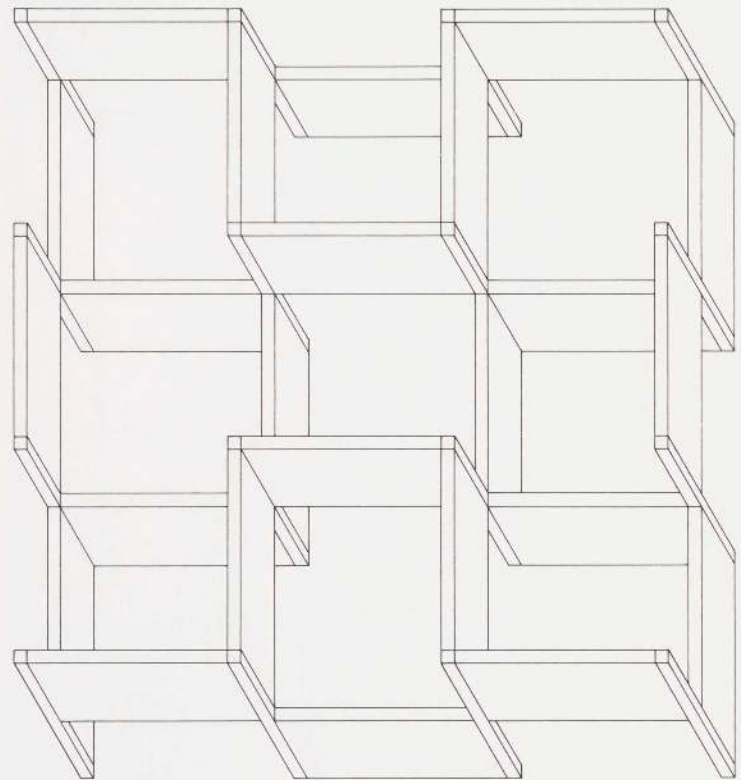
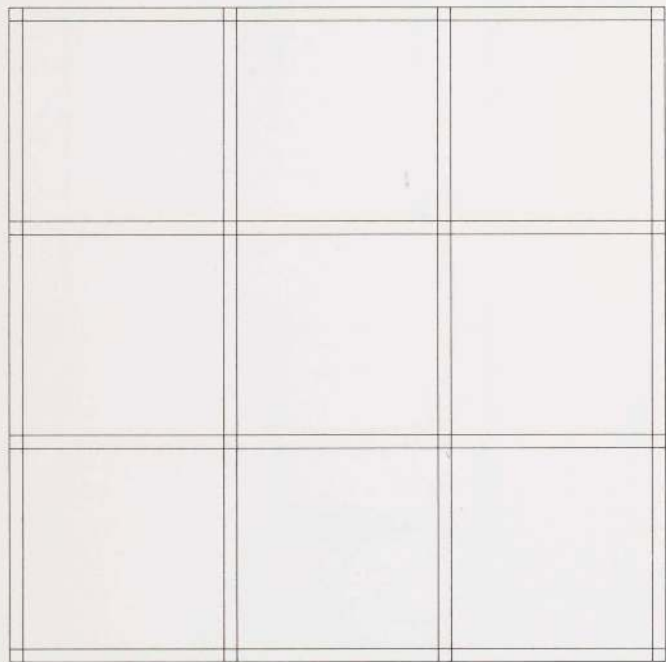

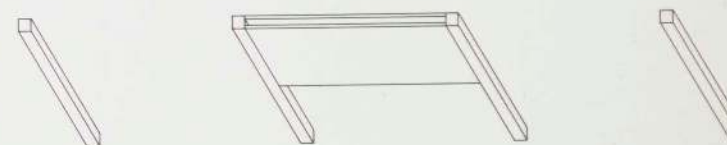
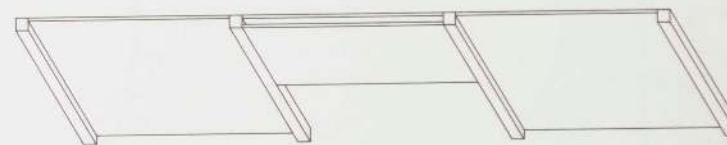
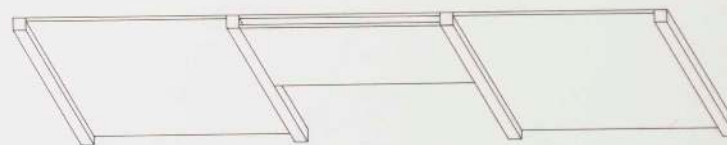
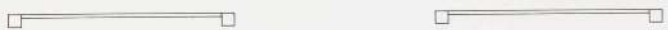

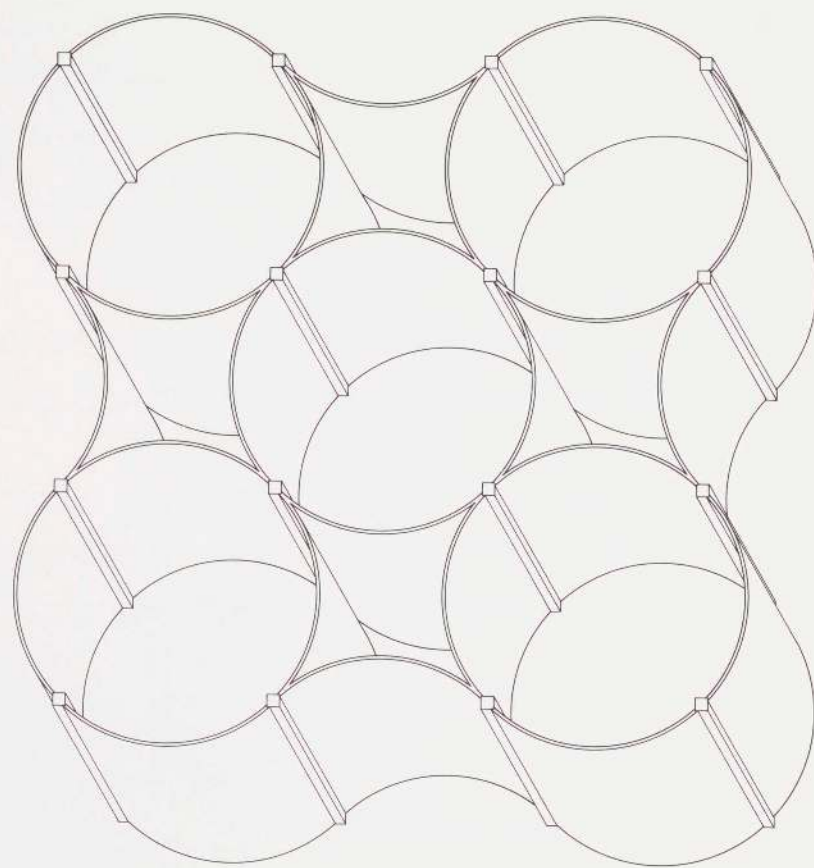
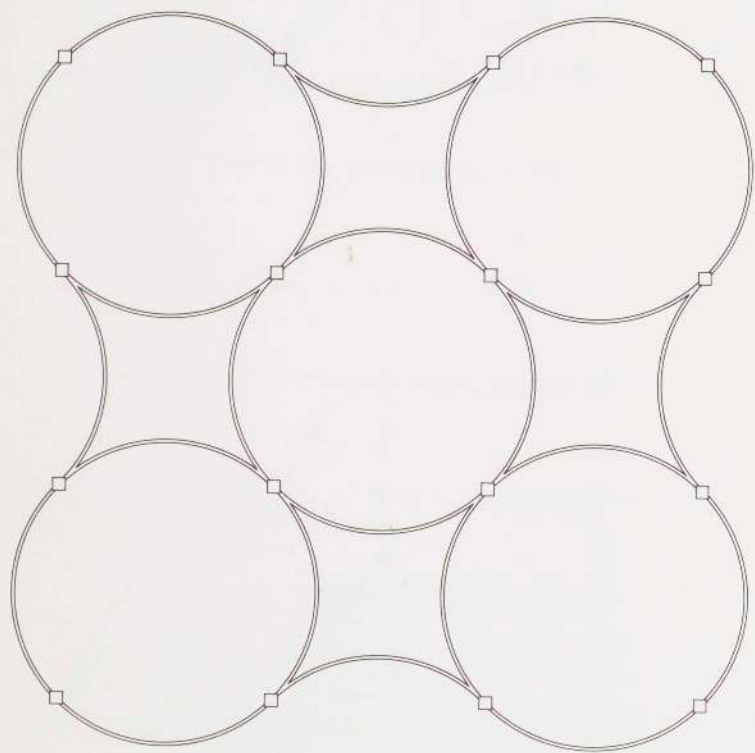

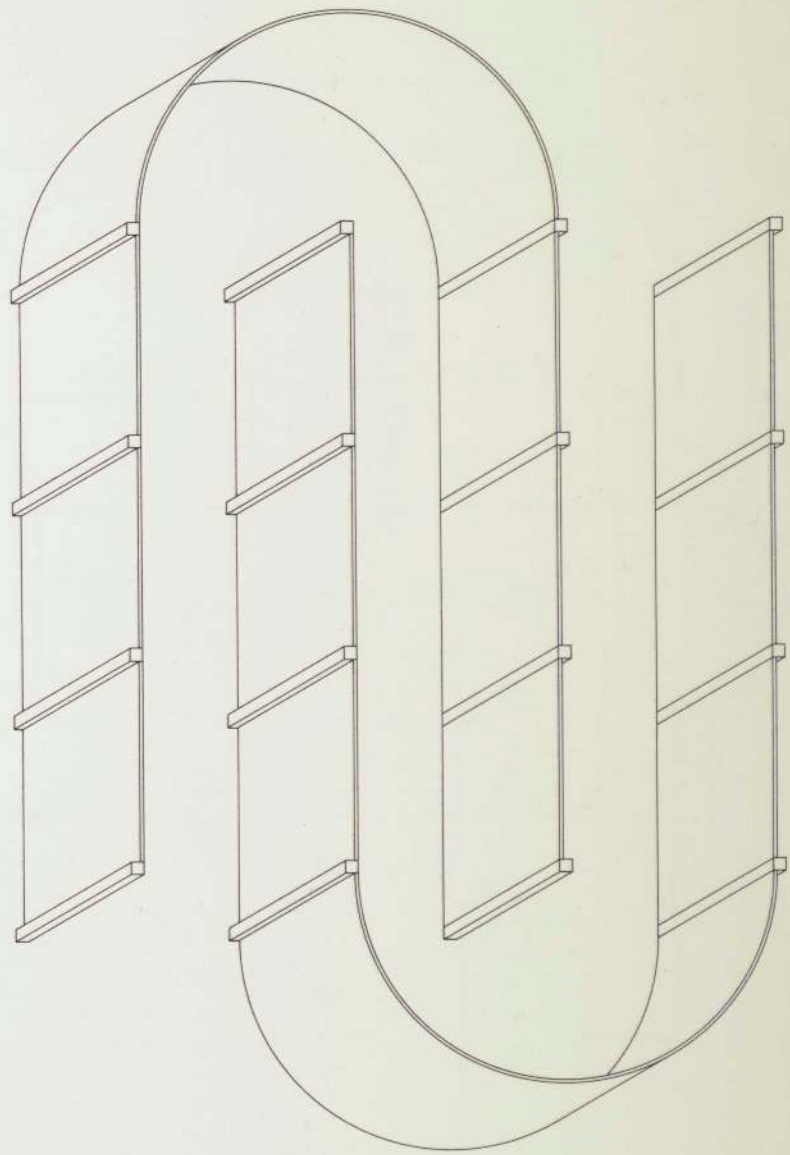
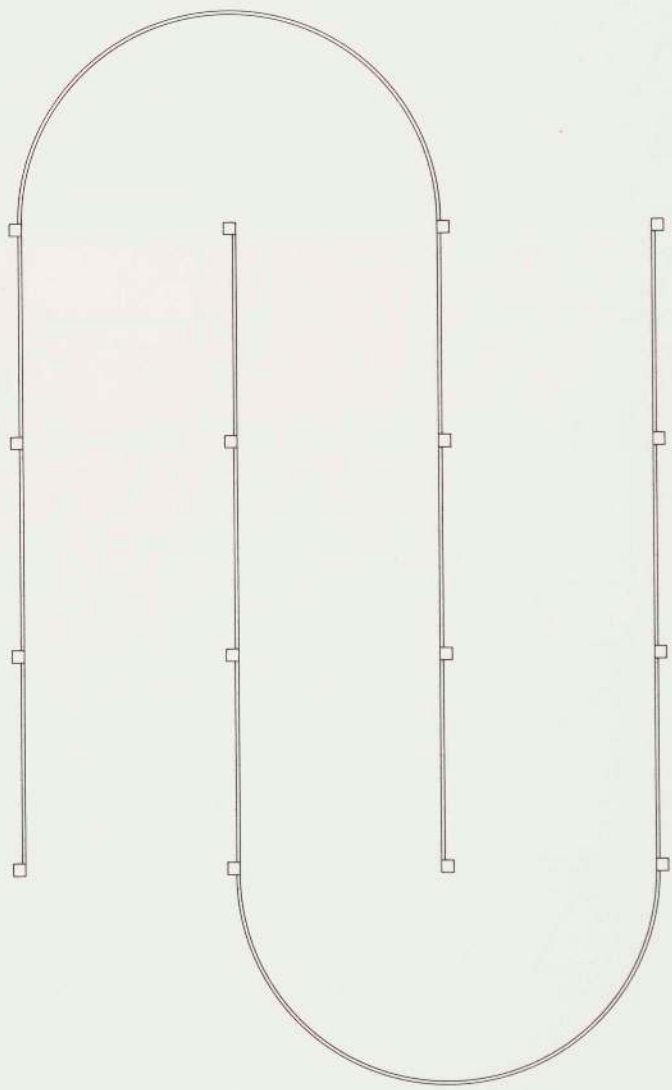

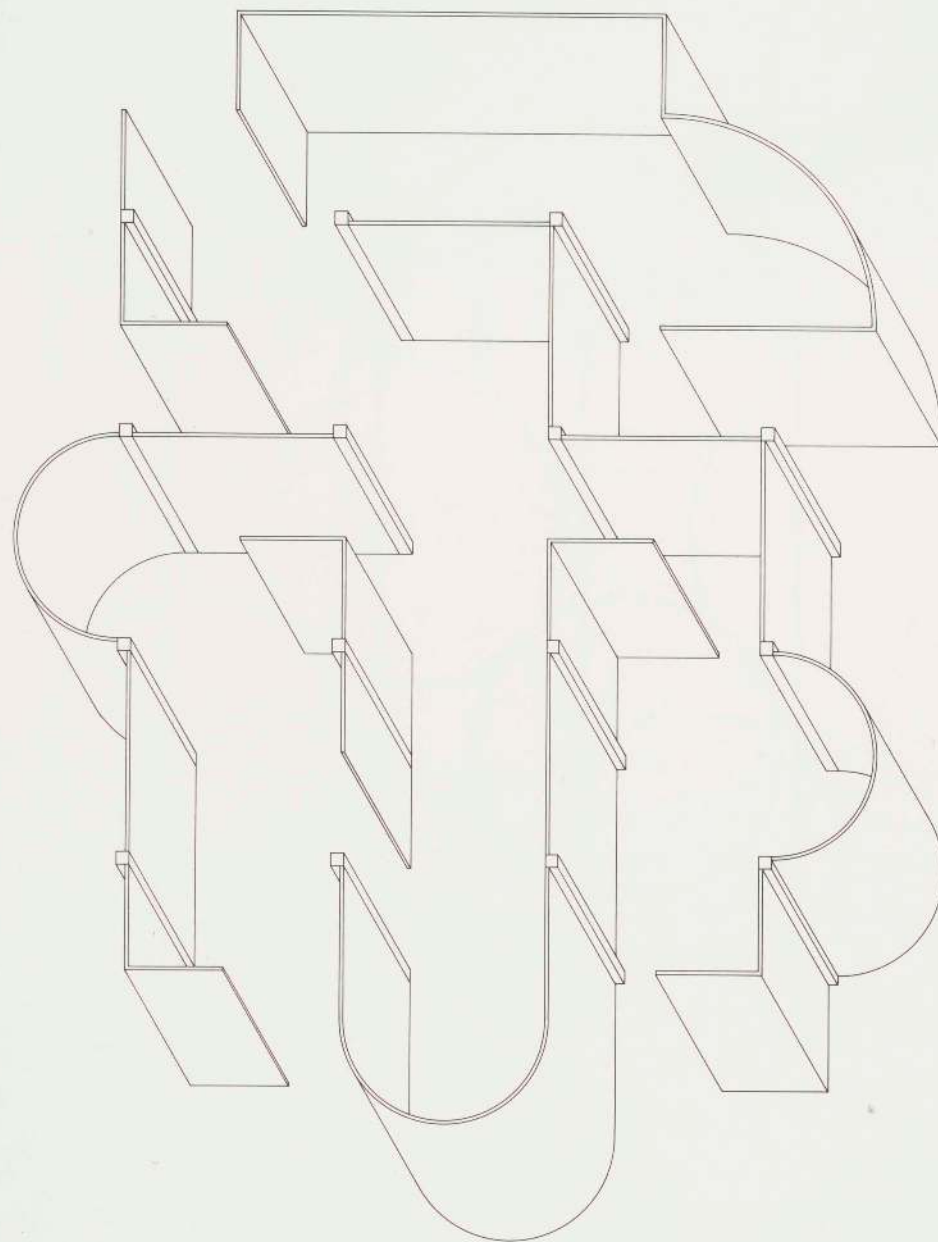
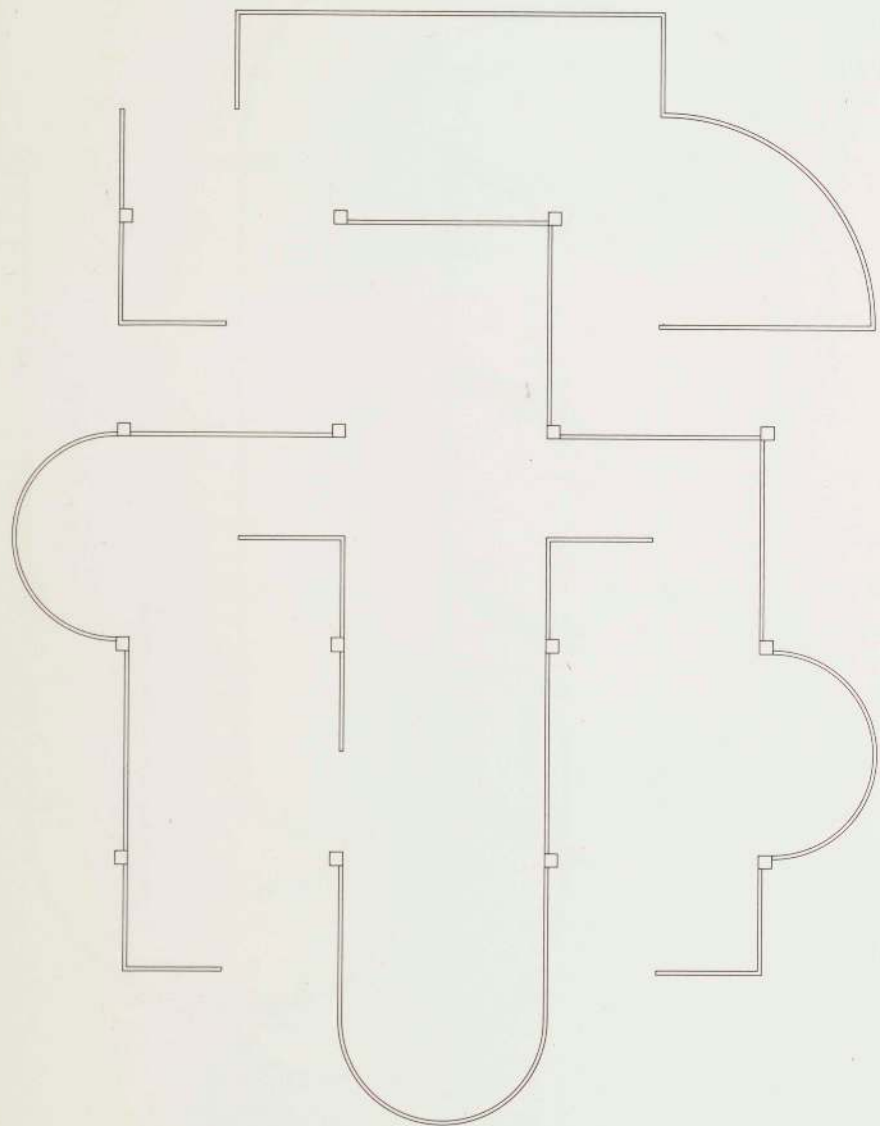

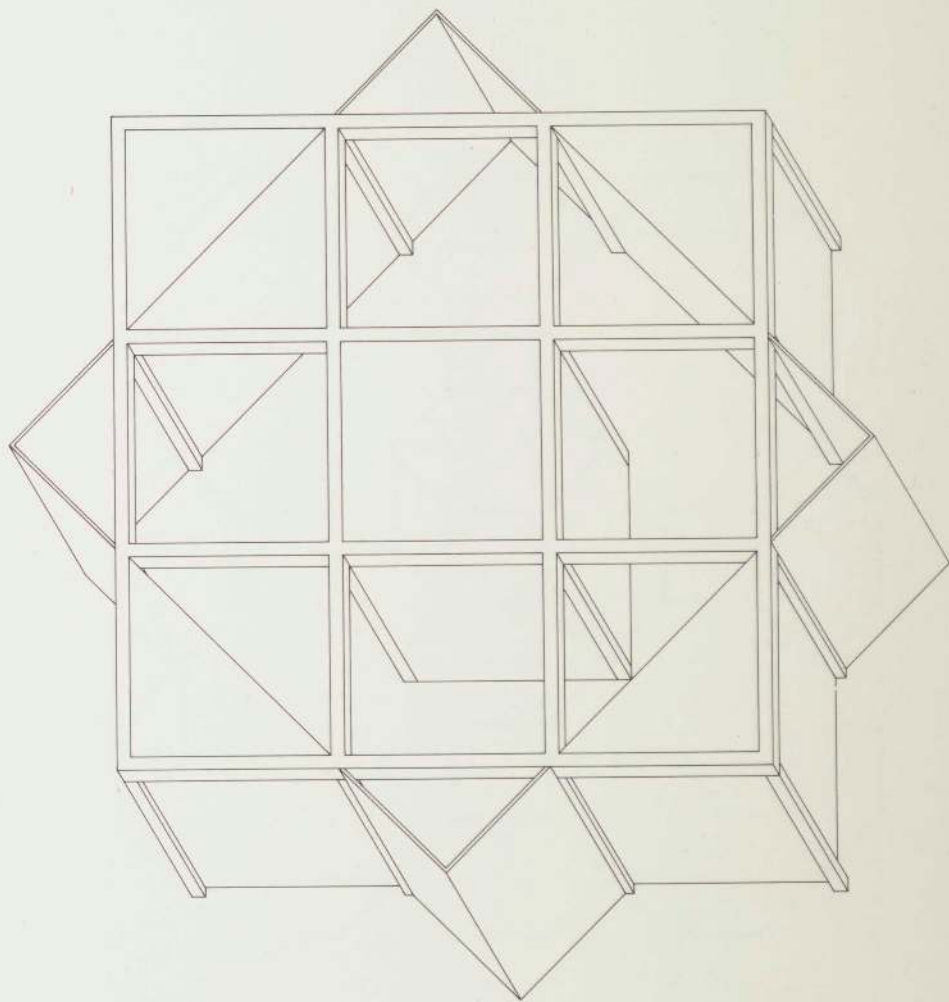
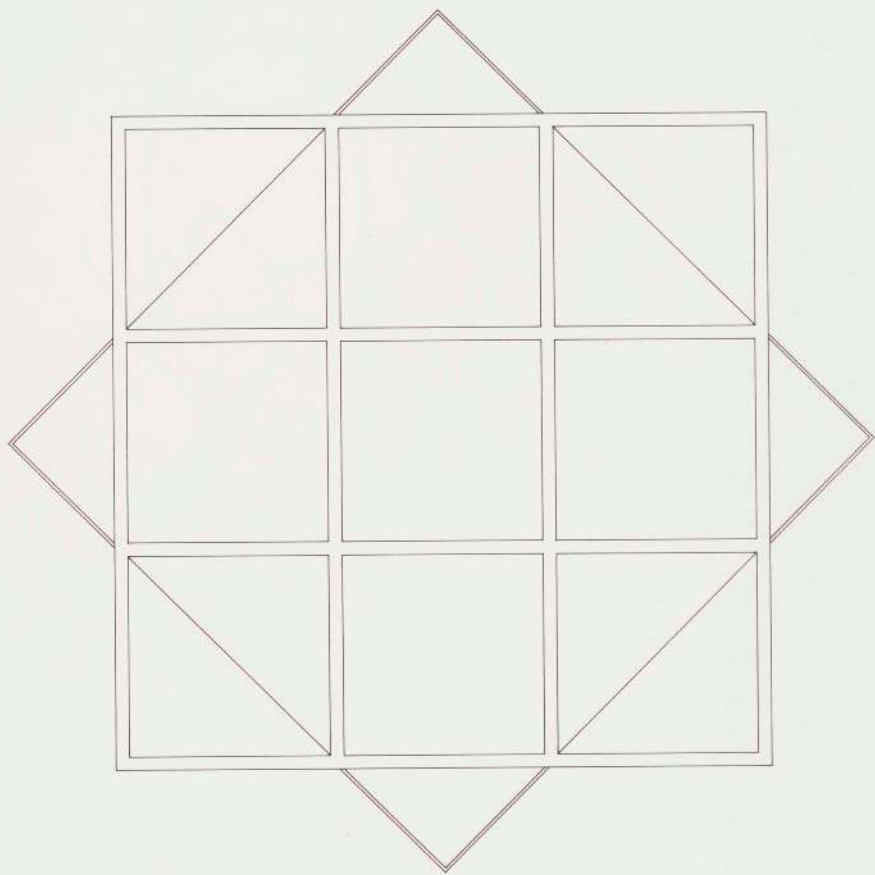

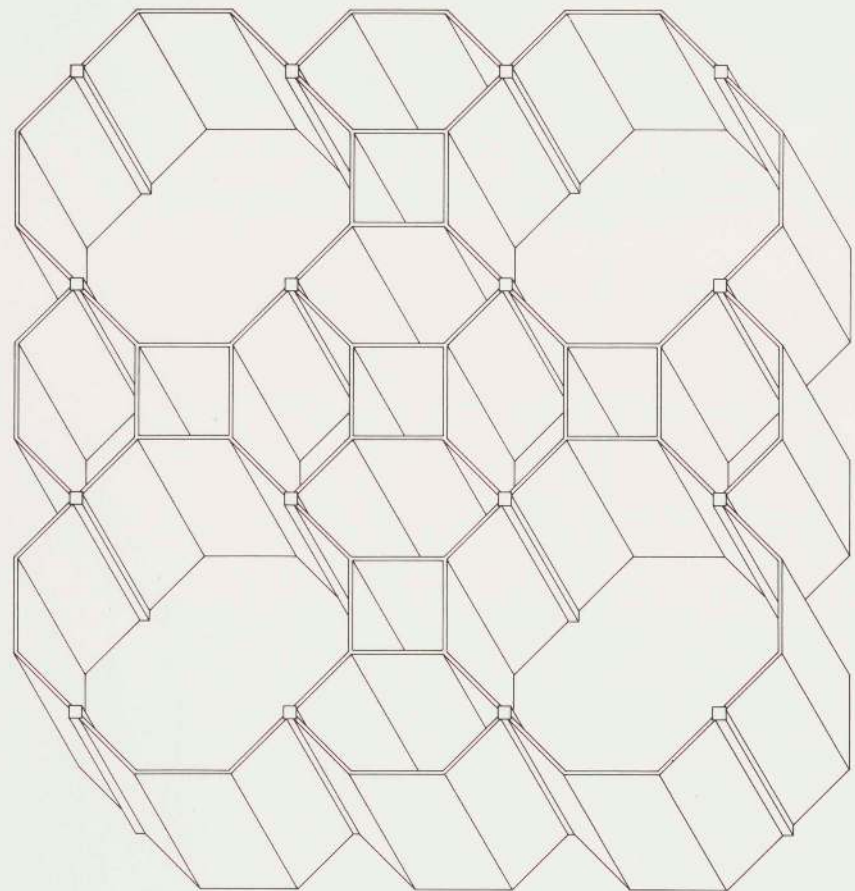
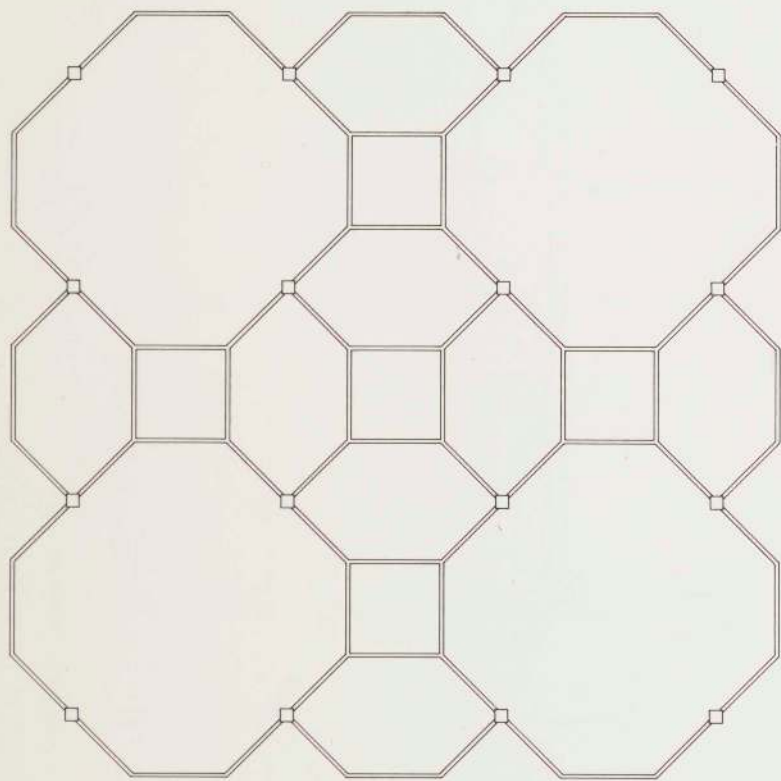

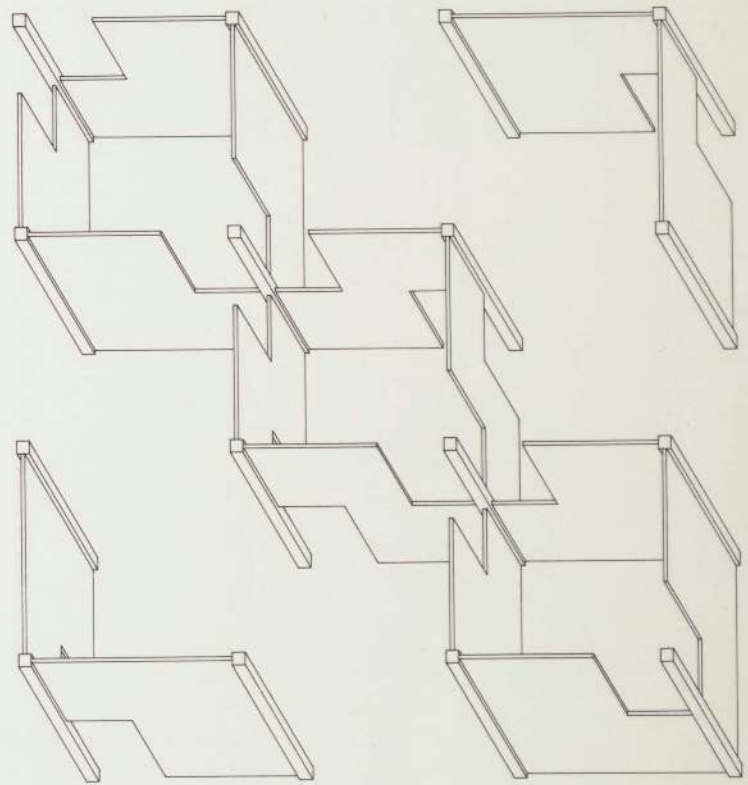
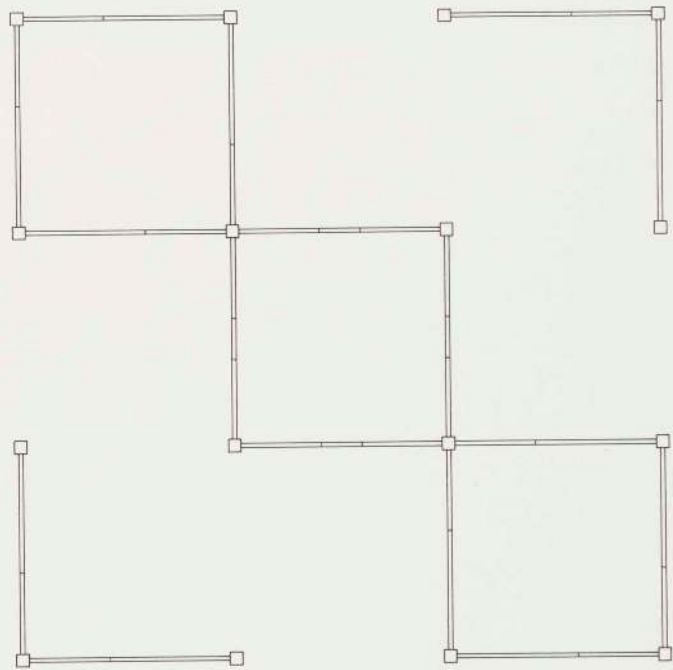

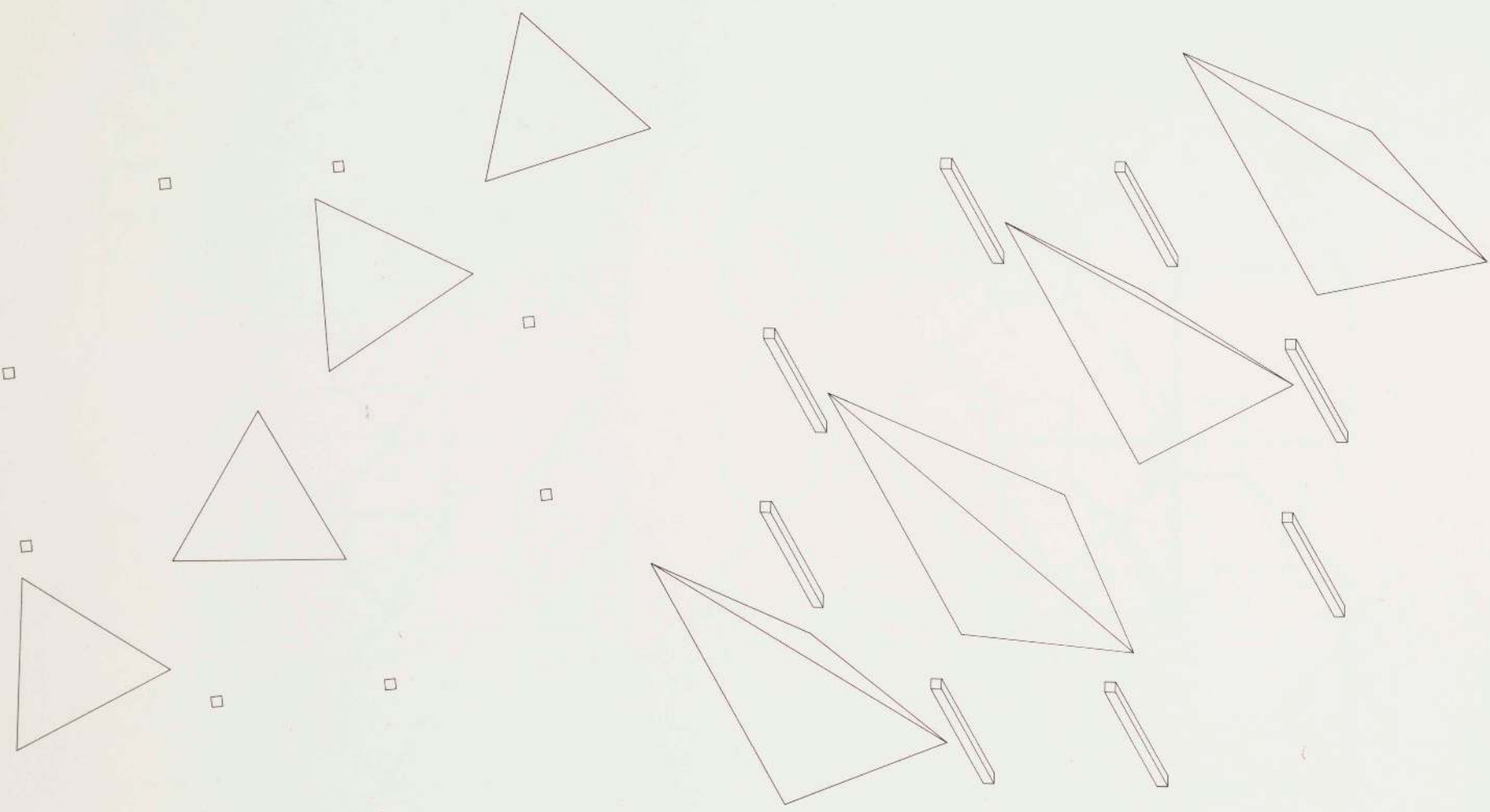

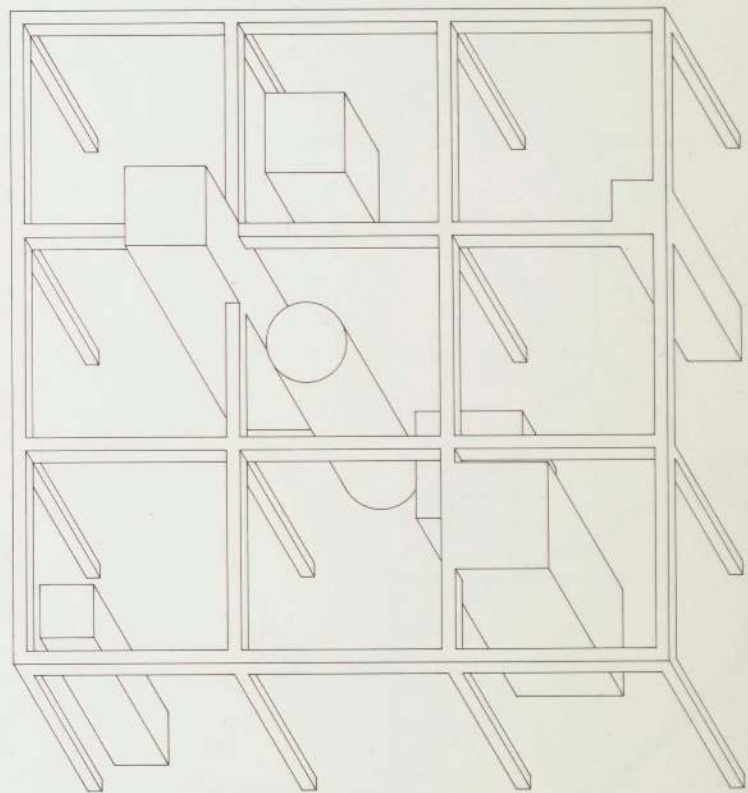
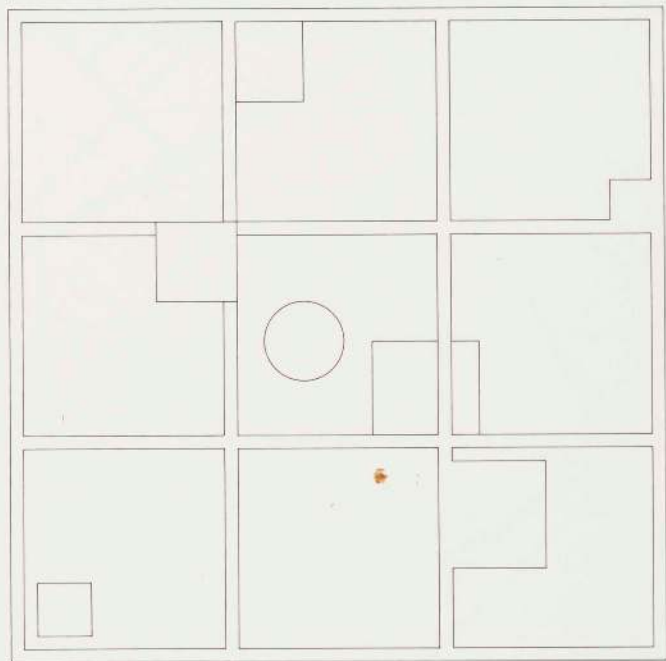

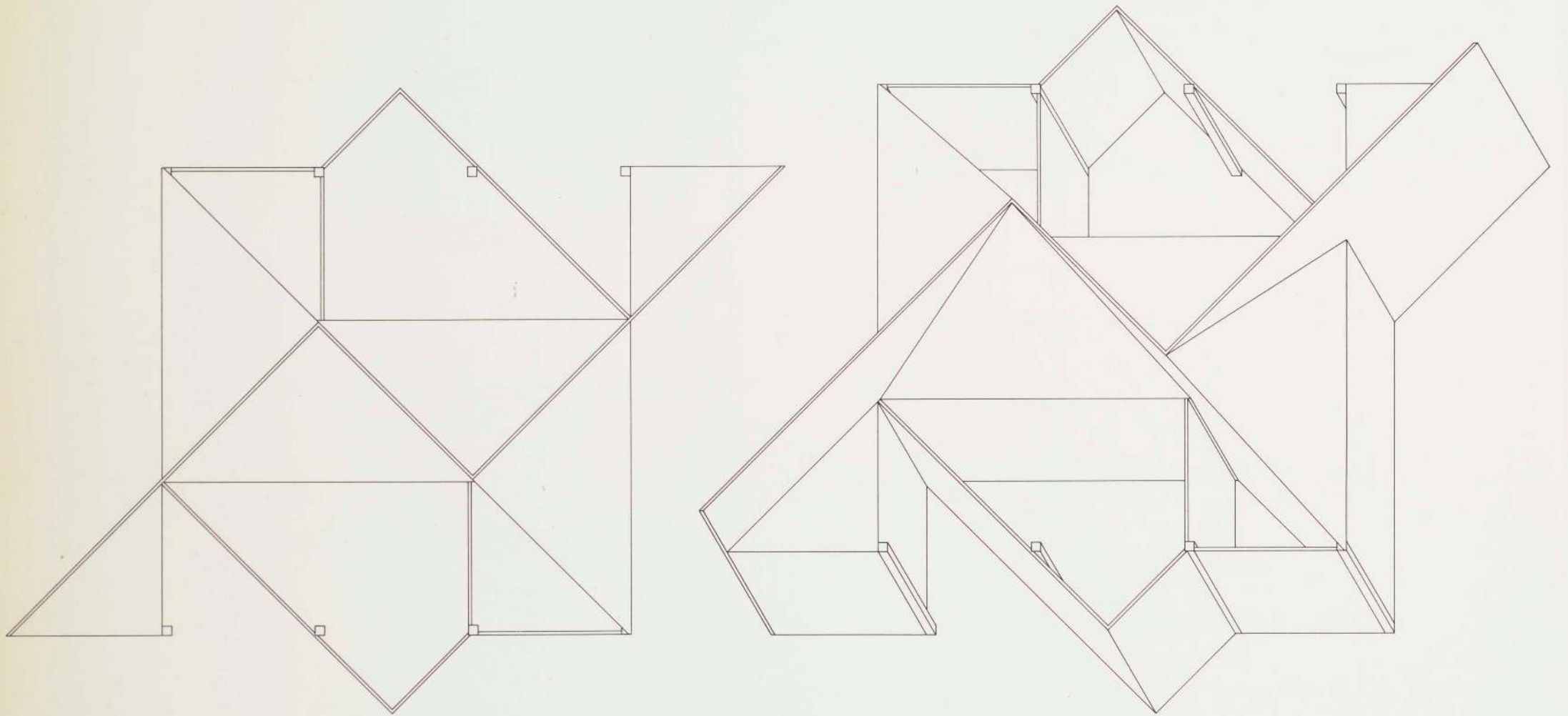

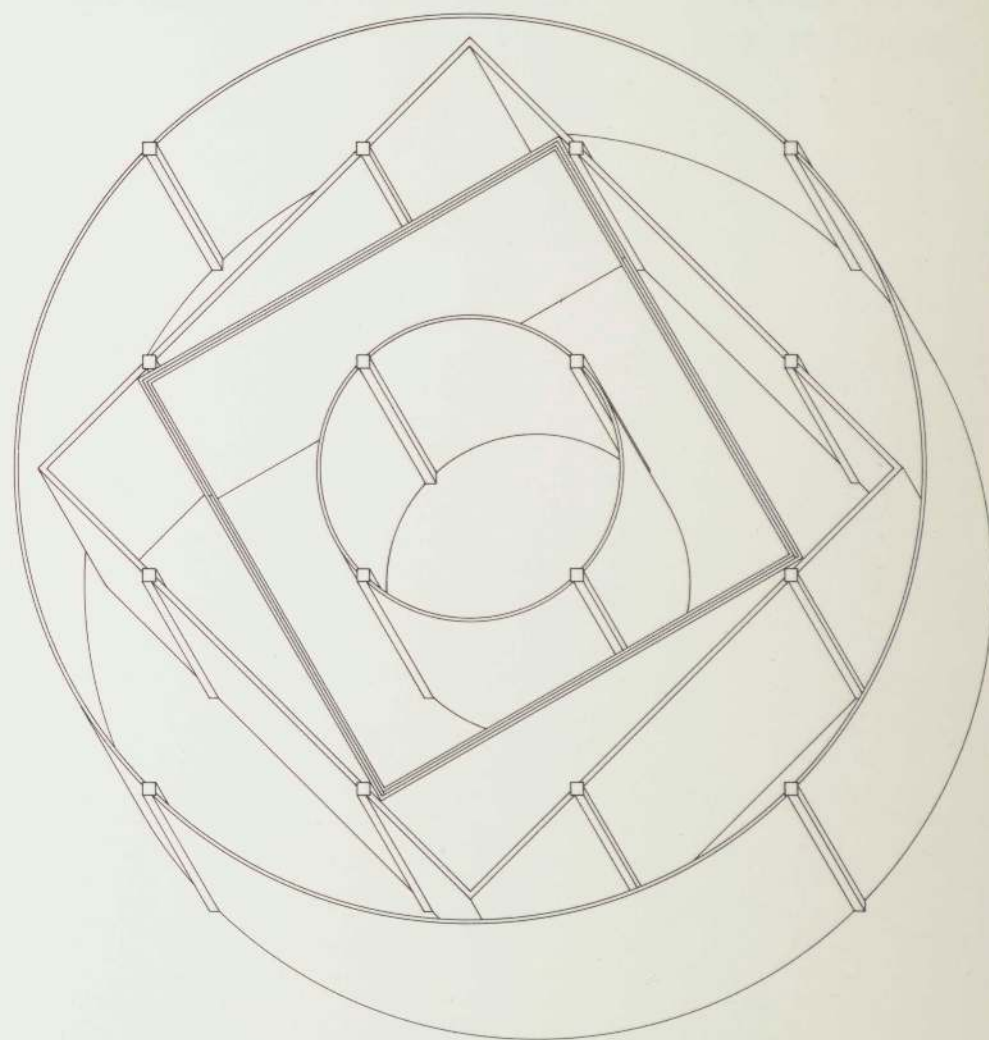
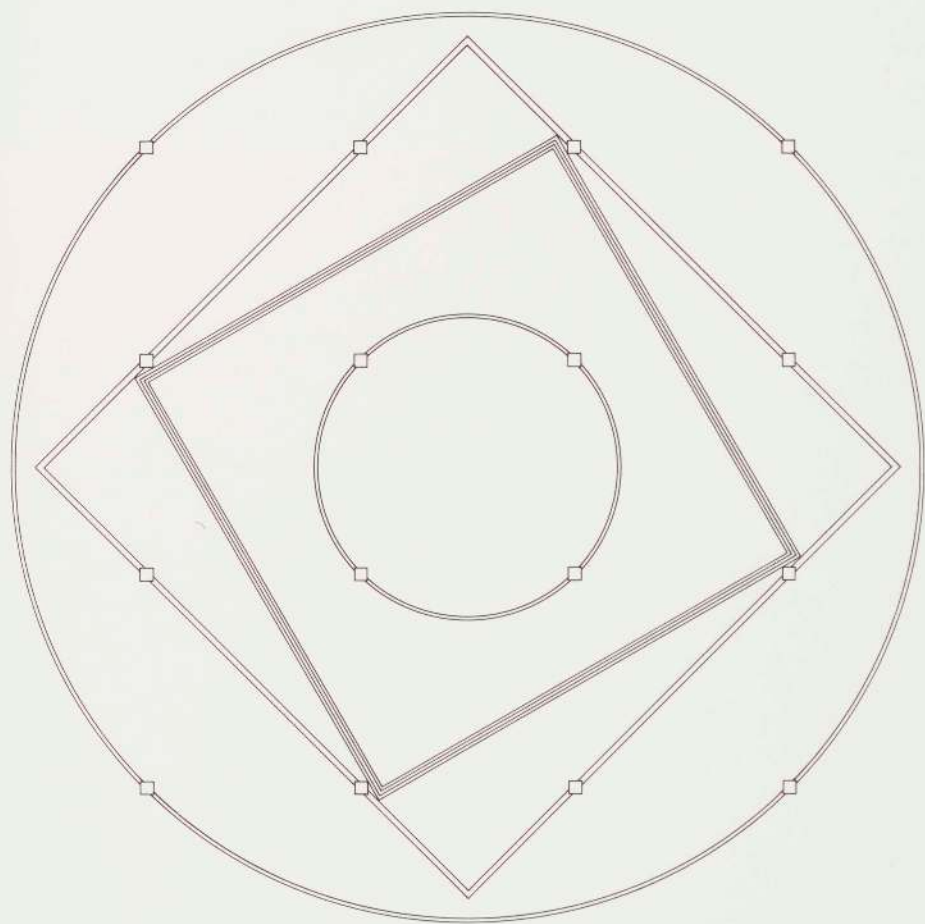

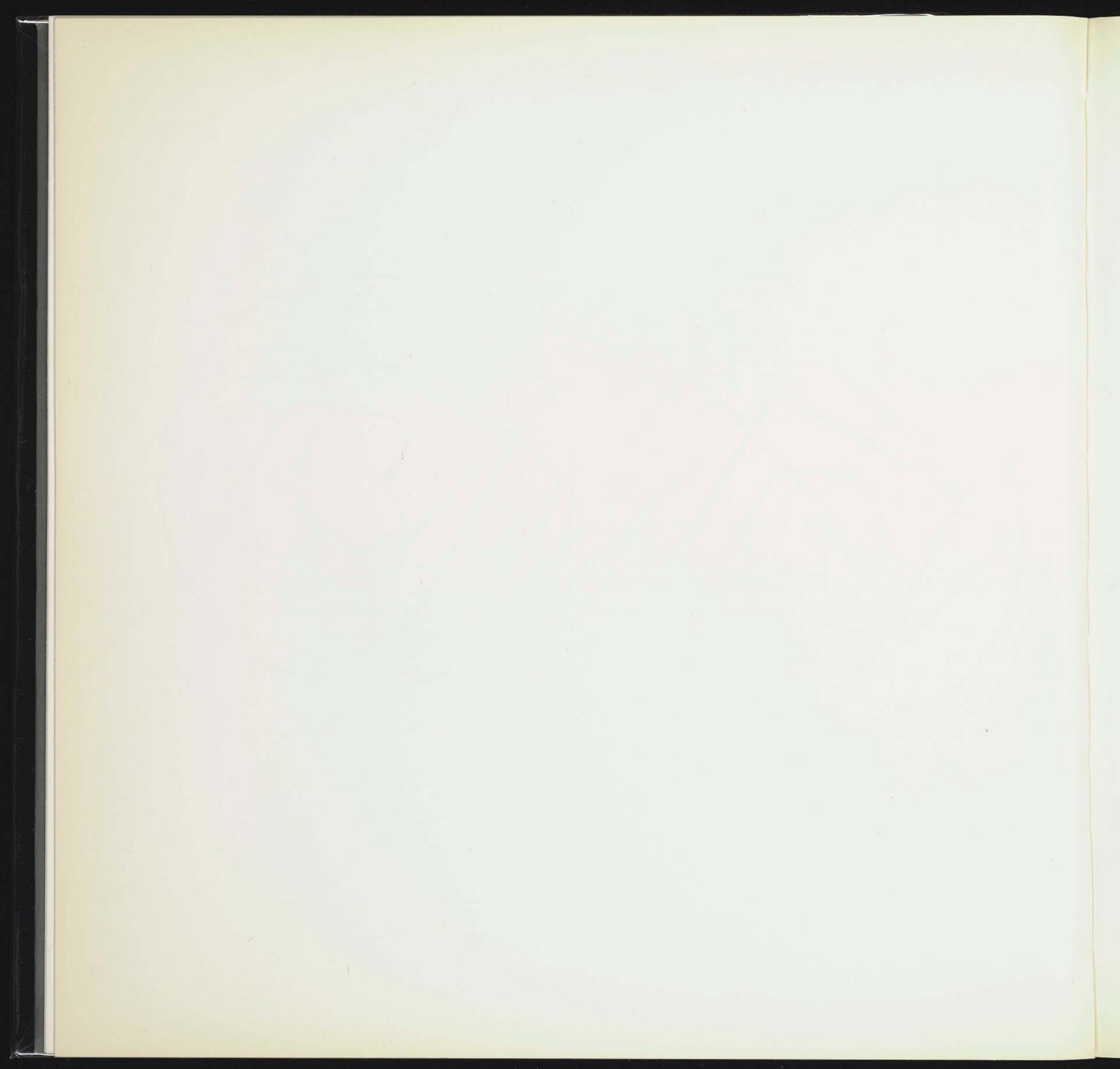

THE NINE-SQUARE PROBLEM. The Nine-Square problem enables an in-depth investigation of binary architectonic relationships—although by no means is it an end in itself. Therefore, flexible model structures are devised to allow for larger and smaller square and non-square structures both in plan and section. Special emphasis is put upon structure(s)—site interactions with their externalized and internalized pressures defined through programmatic and physical parameters. In all cases an insistence upon rules of organization is maintained with the notion that 'concept' and 'percept' not only co-exist but become in fact inseparable within any given solution. Continuous involvement effects a reversal of Gresham's Law whereby the 'good' drives out the 'bad' (aesthetically speaking) . . . concurrently demanding re-evaluation and modification of previously held architectural prejudices.

Robert Slutzky

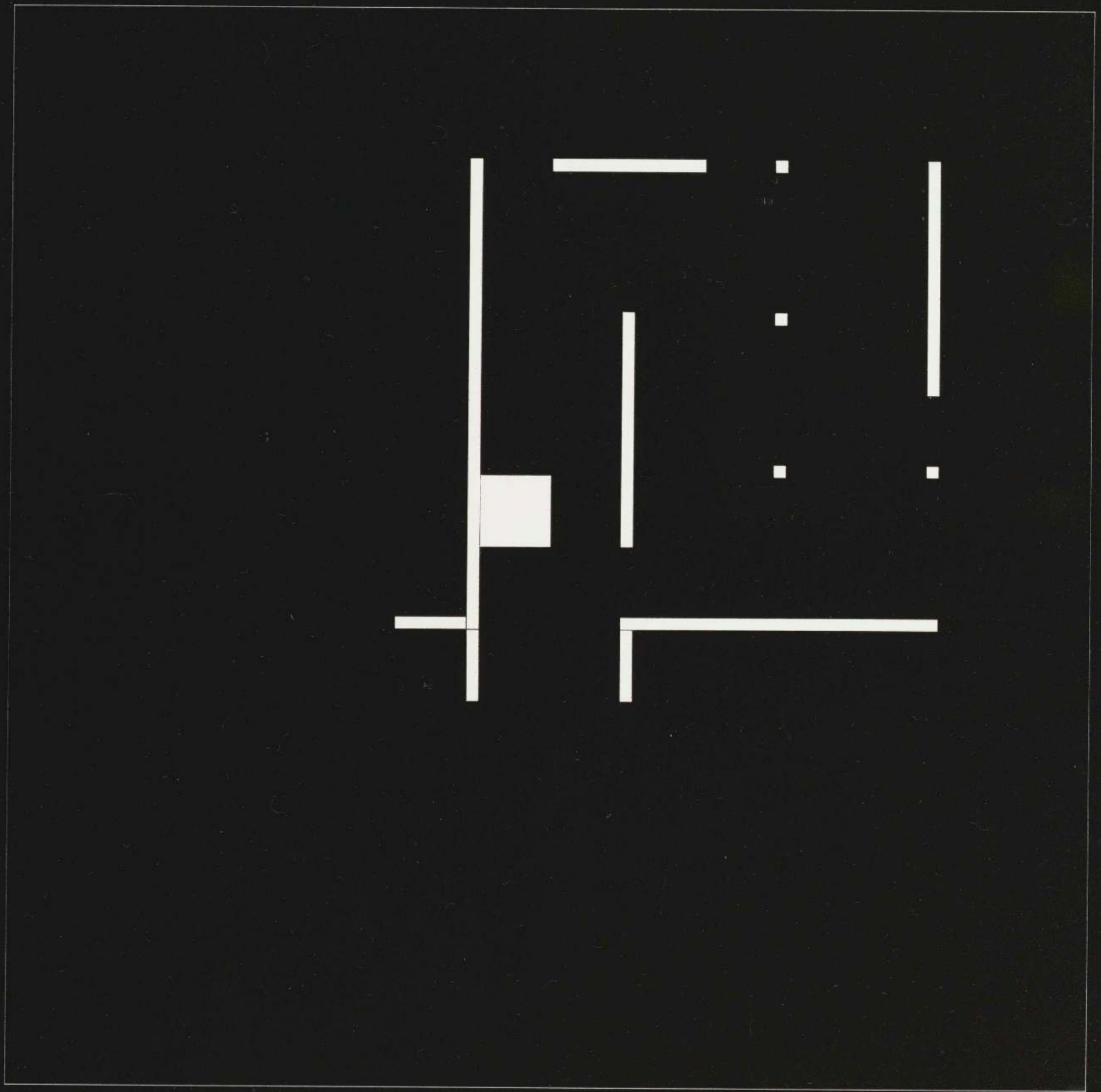

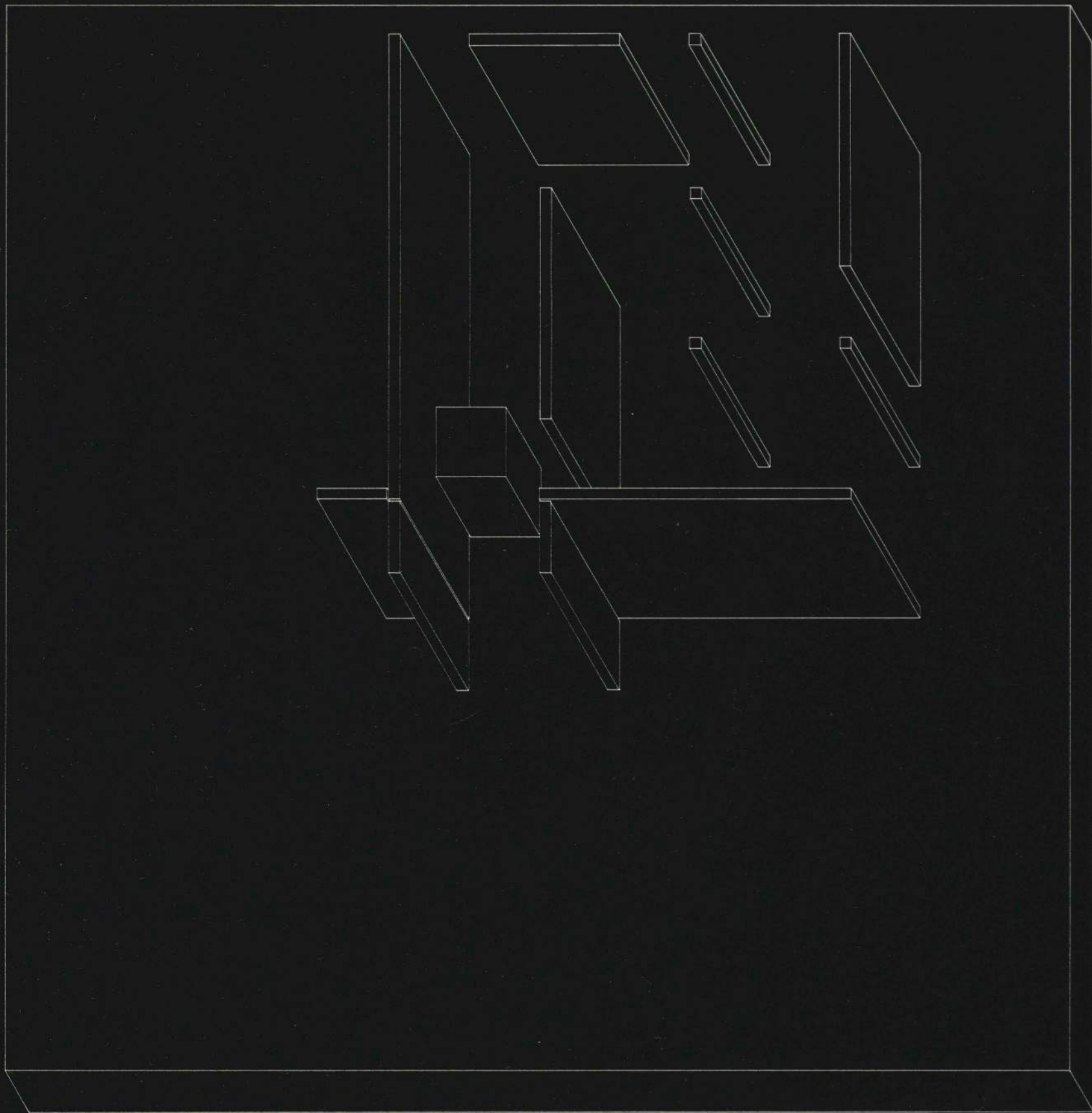

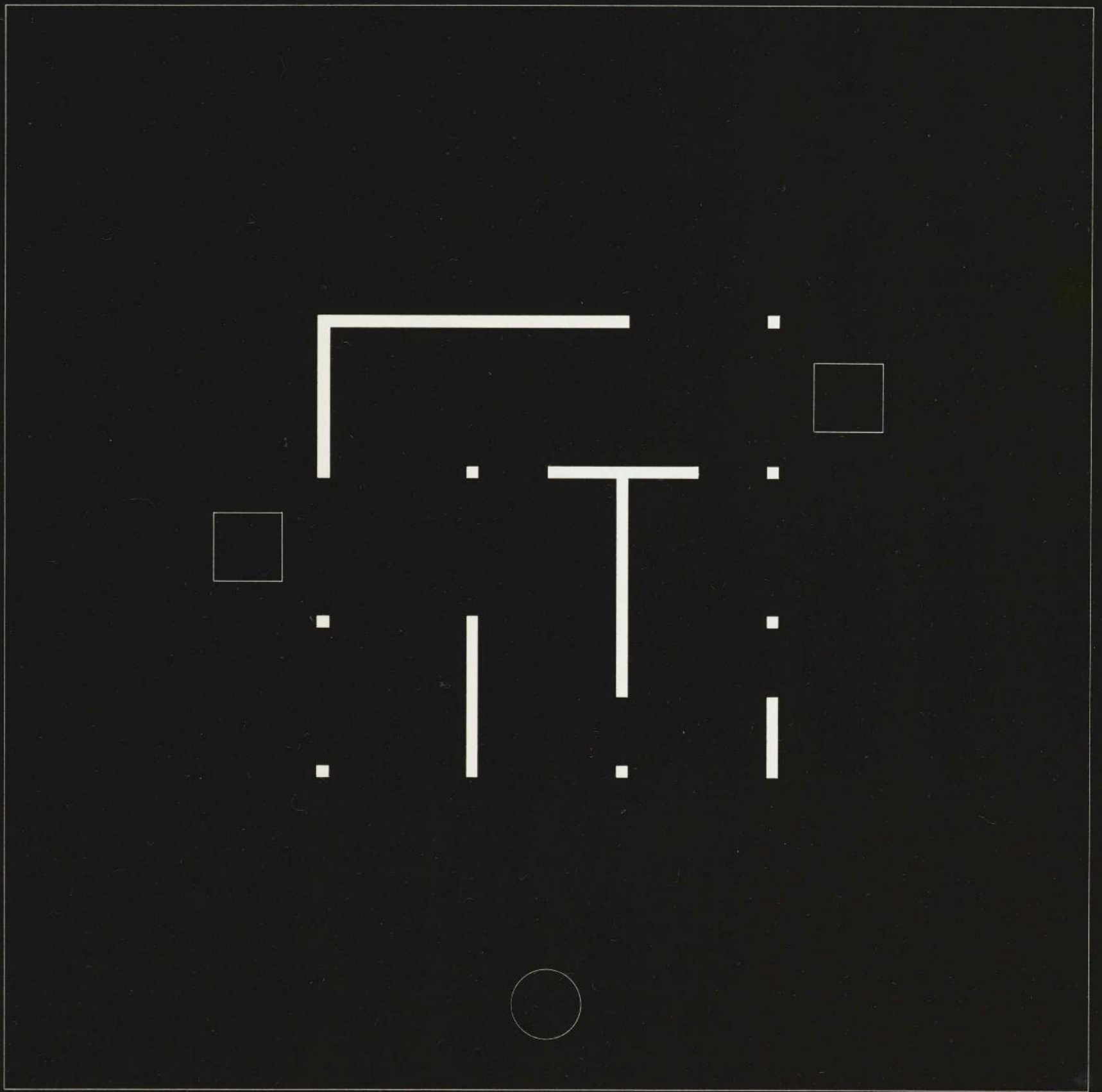

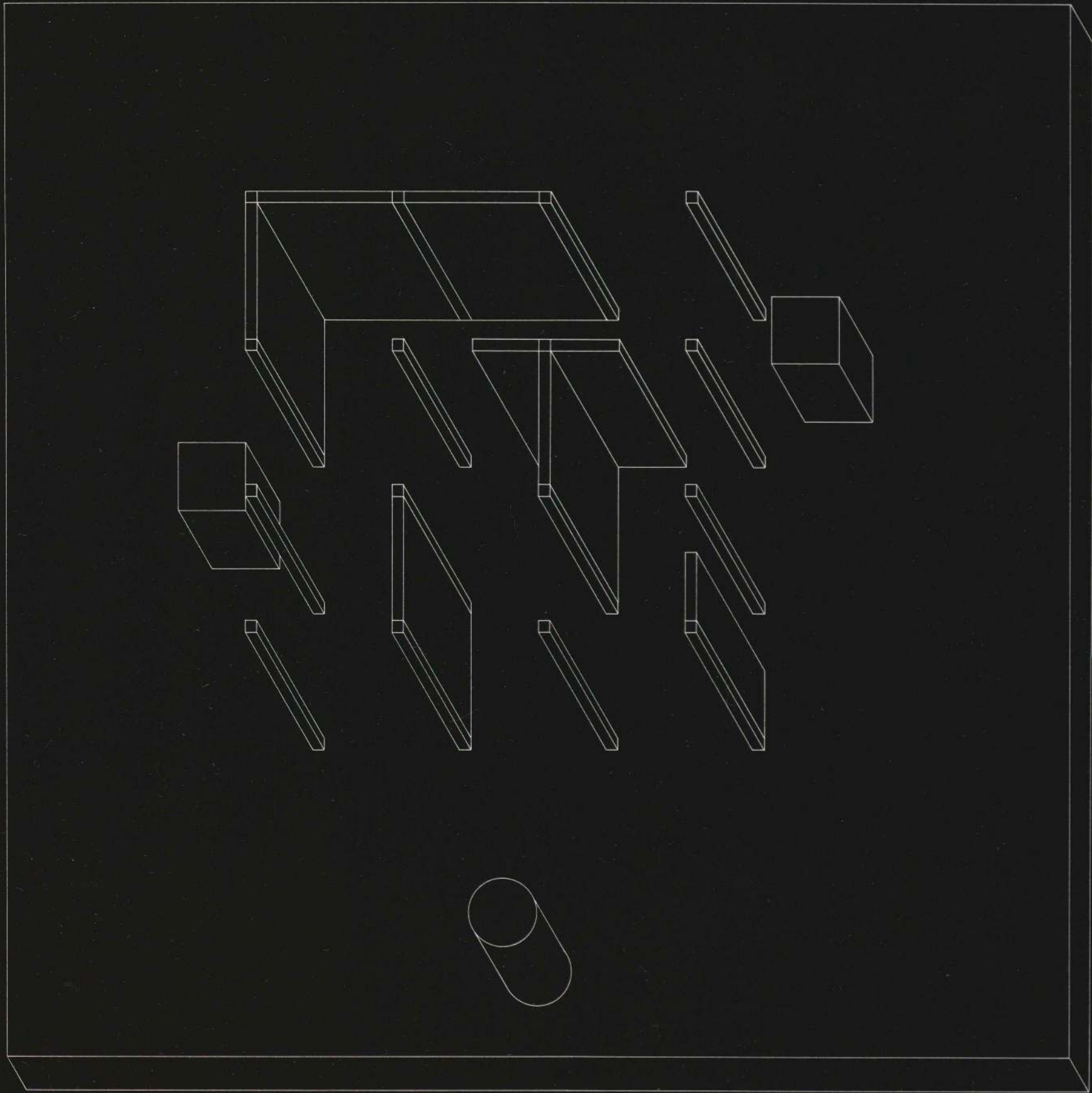

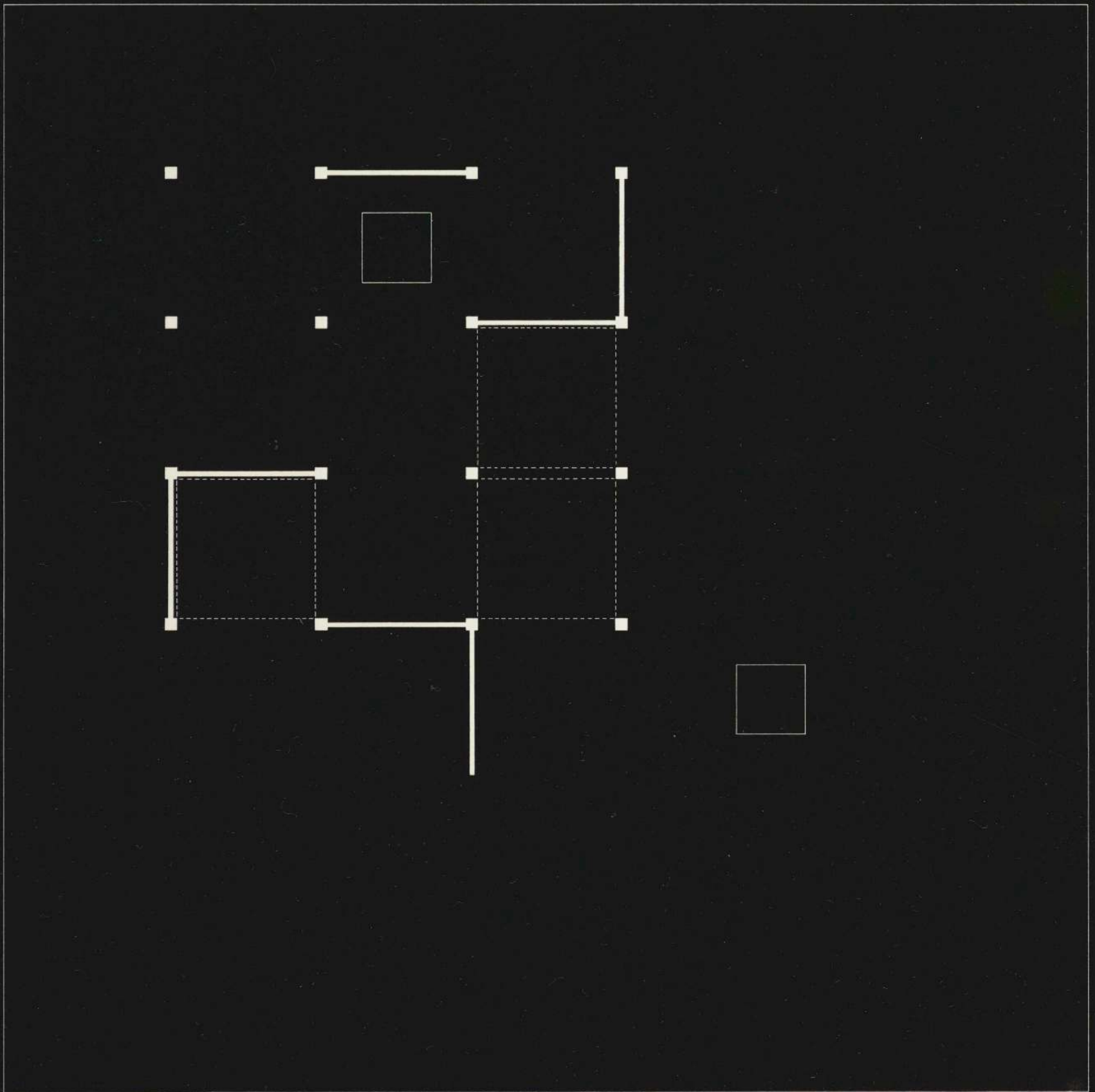

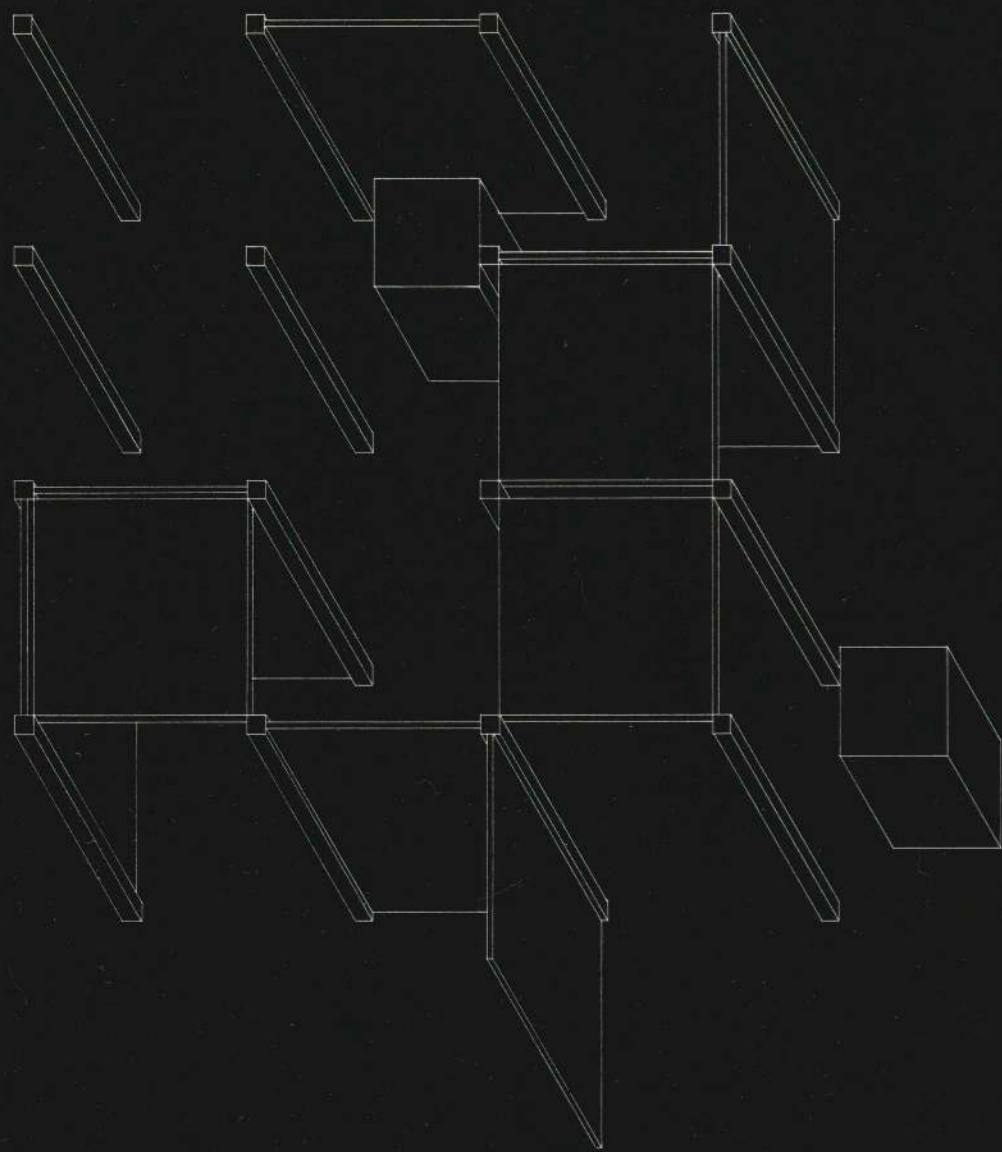

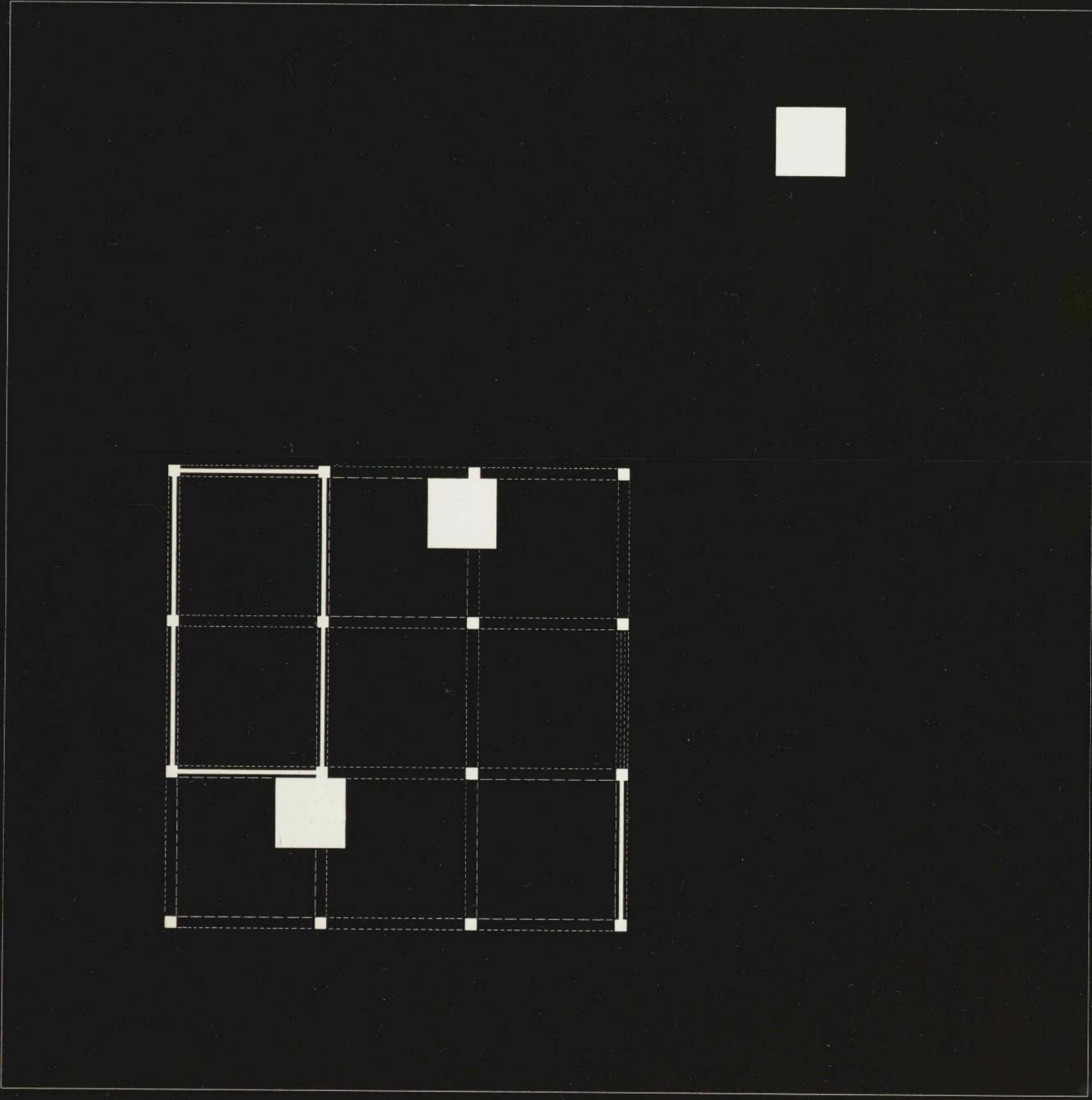

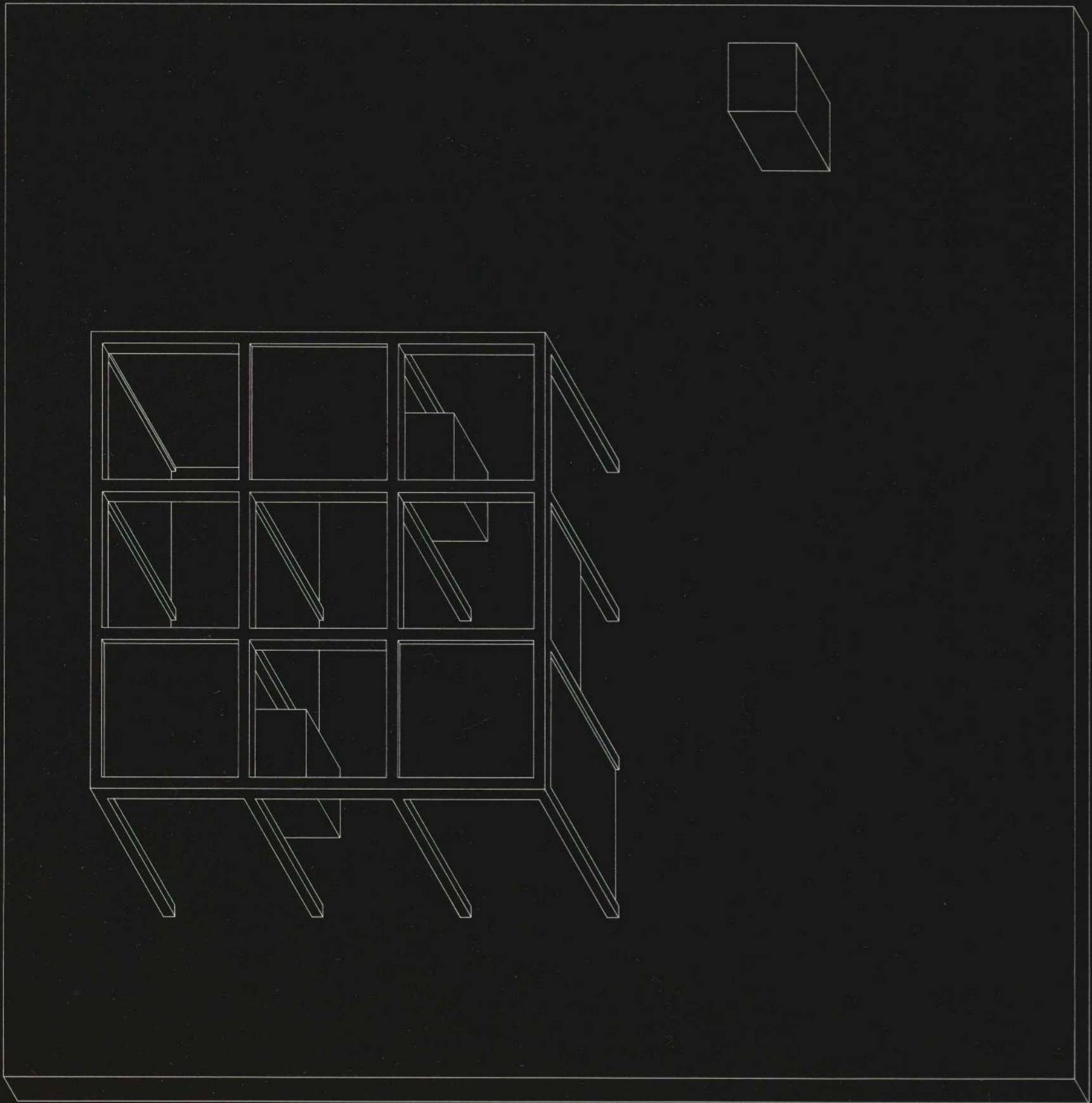

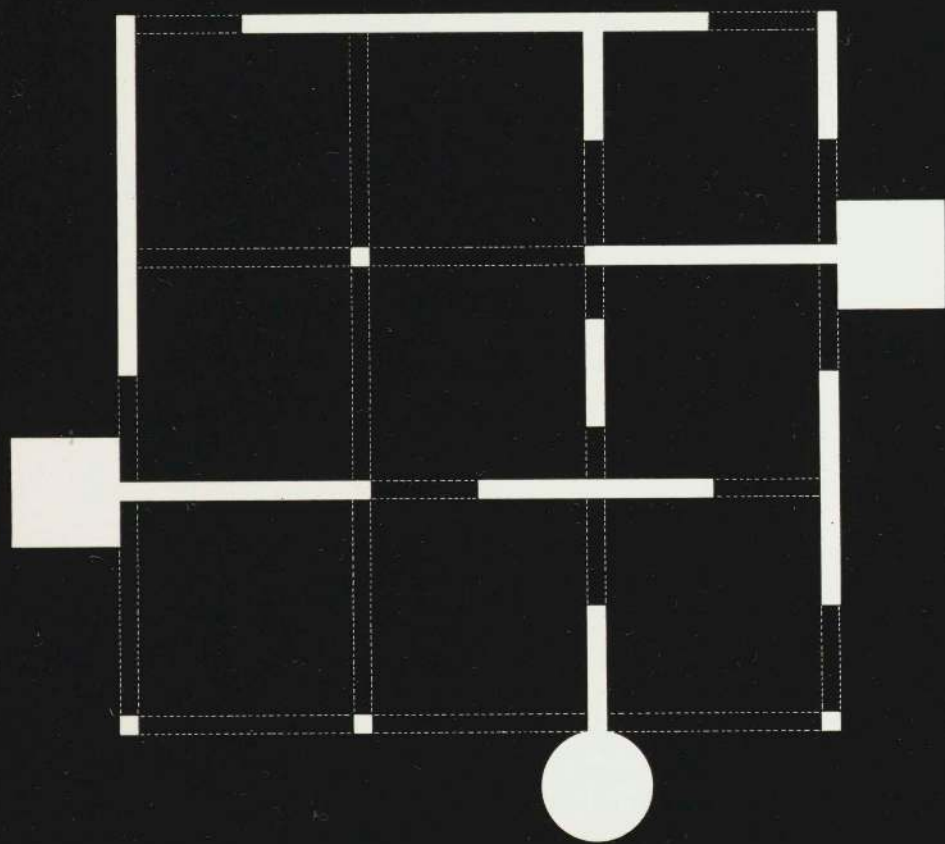

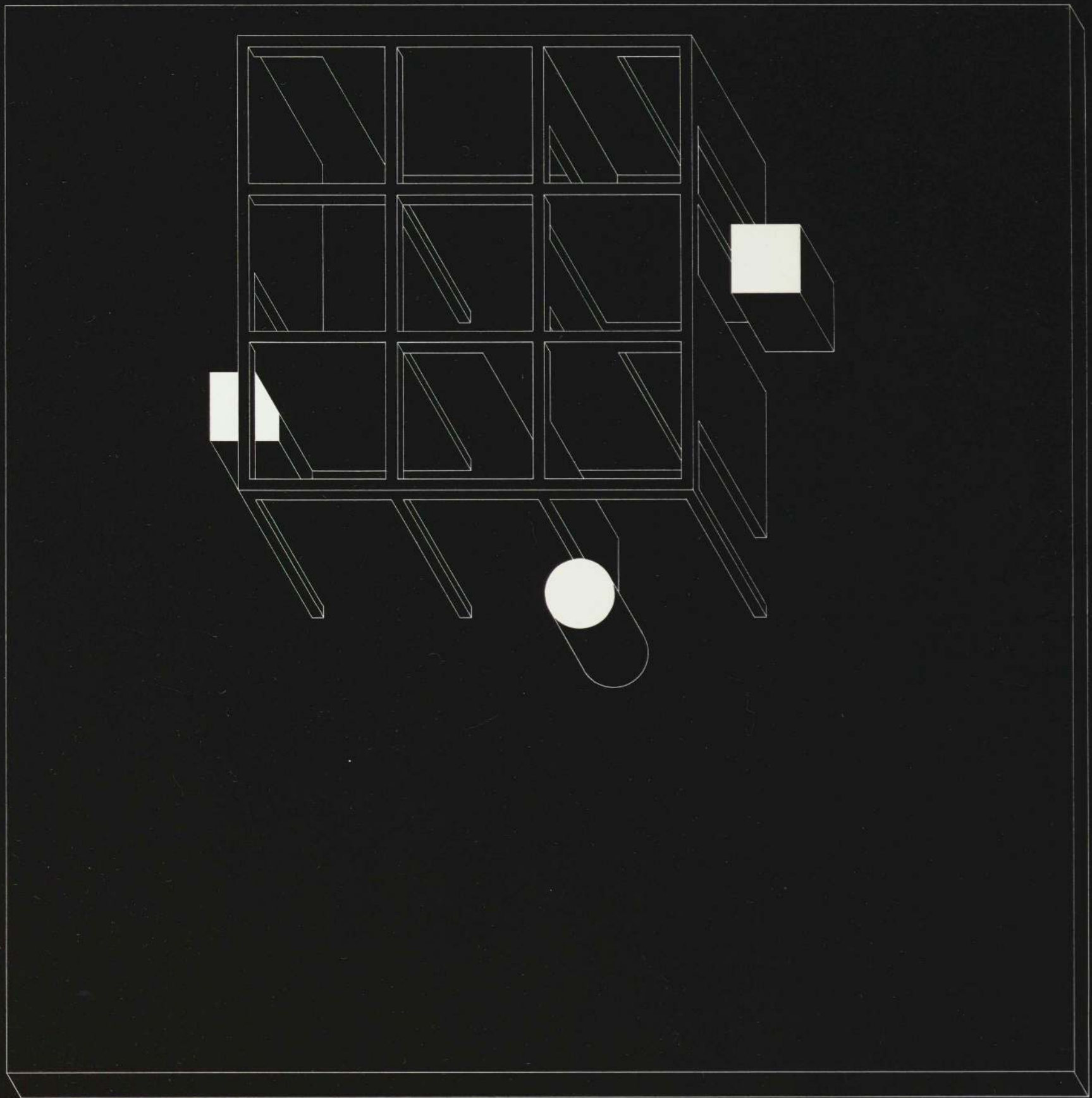



FREEHAND DRAWING. The Freehand Drawing course has as its primary objective the development of the student's basic manual graphic skills. These are to be ultimately used in formulating a personal means of visual communication. It is drawing taught as a craft and begins with an exploration of the extent and limitations of the pencil, the only tool used. Through a series of changing problems, the student develops enough manipulative control so that without the aid of a straightedge, compass, or eraser, he is soon able to draw a line that is straight, and a circle that is round. The student does not erase, or correct his drawings by going over his lines, but rather attempts to draw accurately from the very beginning. All drawing is done with a single fresh line with control over its weight and thickness. Once a reasonable degree of manual control has been achieved, the student is given various three-dimensional objects to draw. Emphasis is upon communicating the specific characteristics and spatial aspects of these objects and their voids. Finally, complex spatial problems are given which must first be solved conceptually.

Irwin Rubin

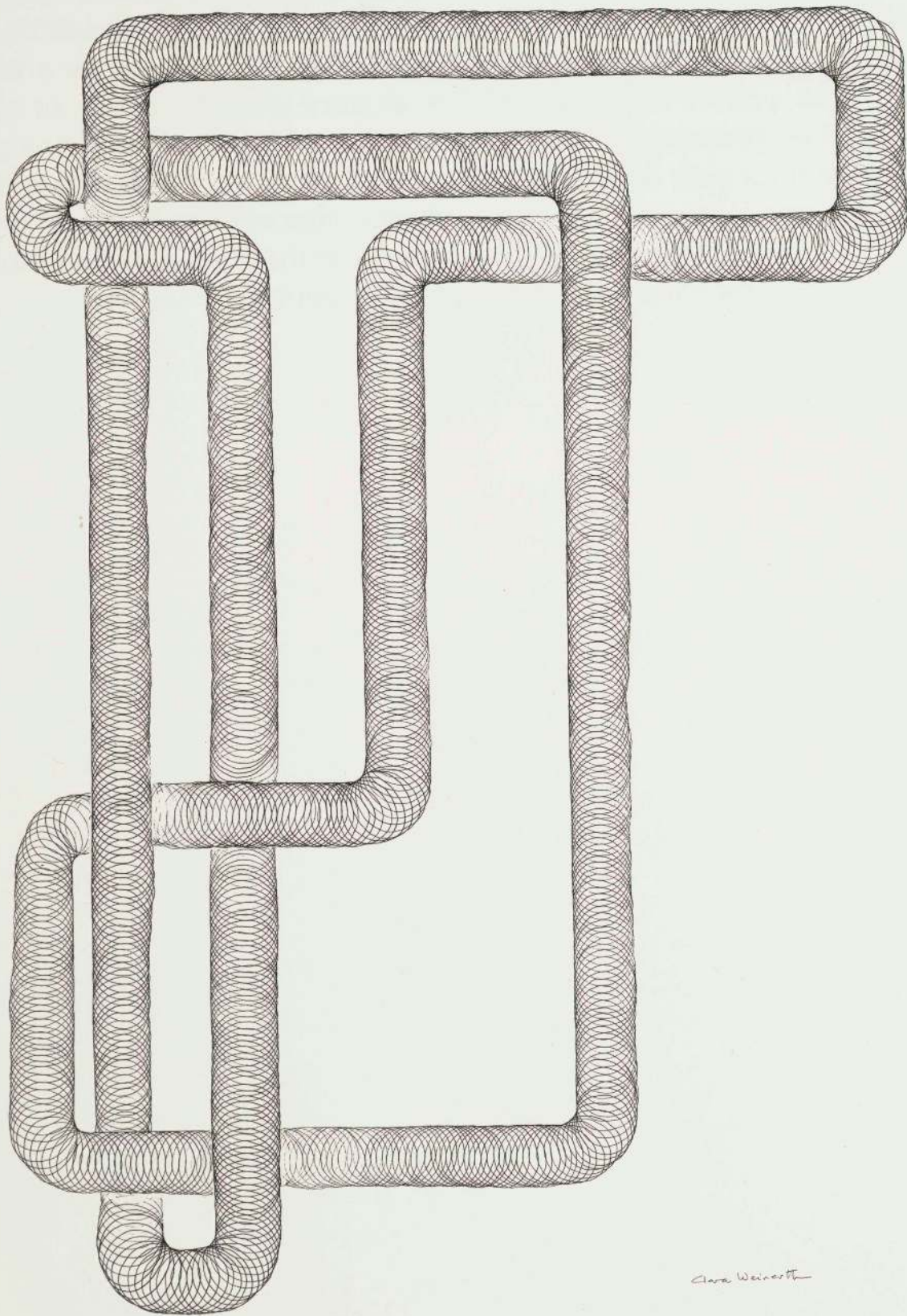

Clara Weinsth

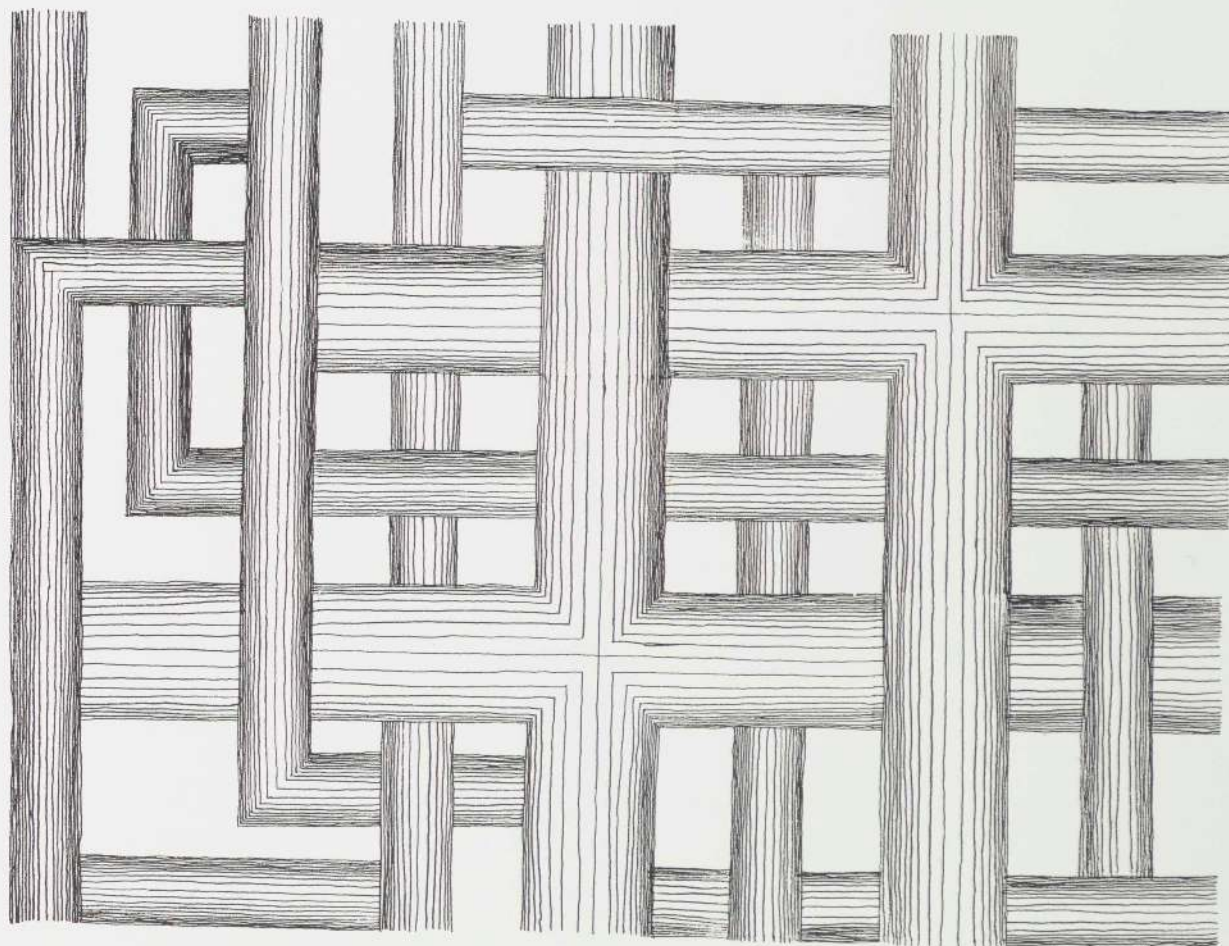

Sammy Chin



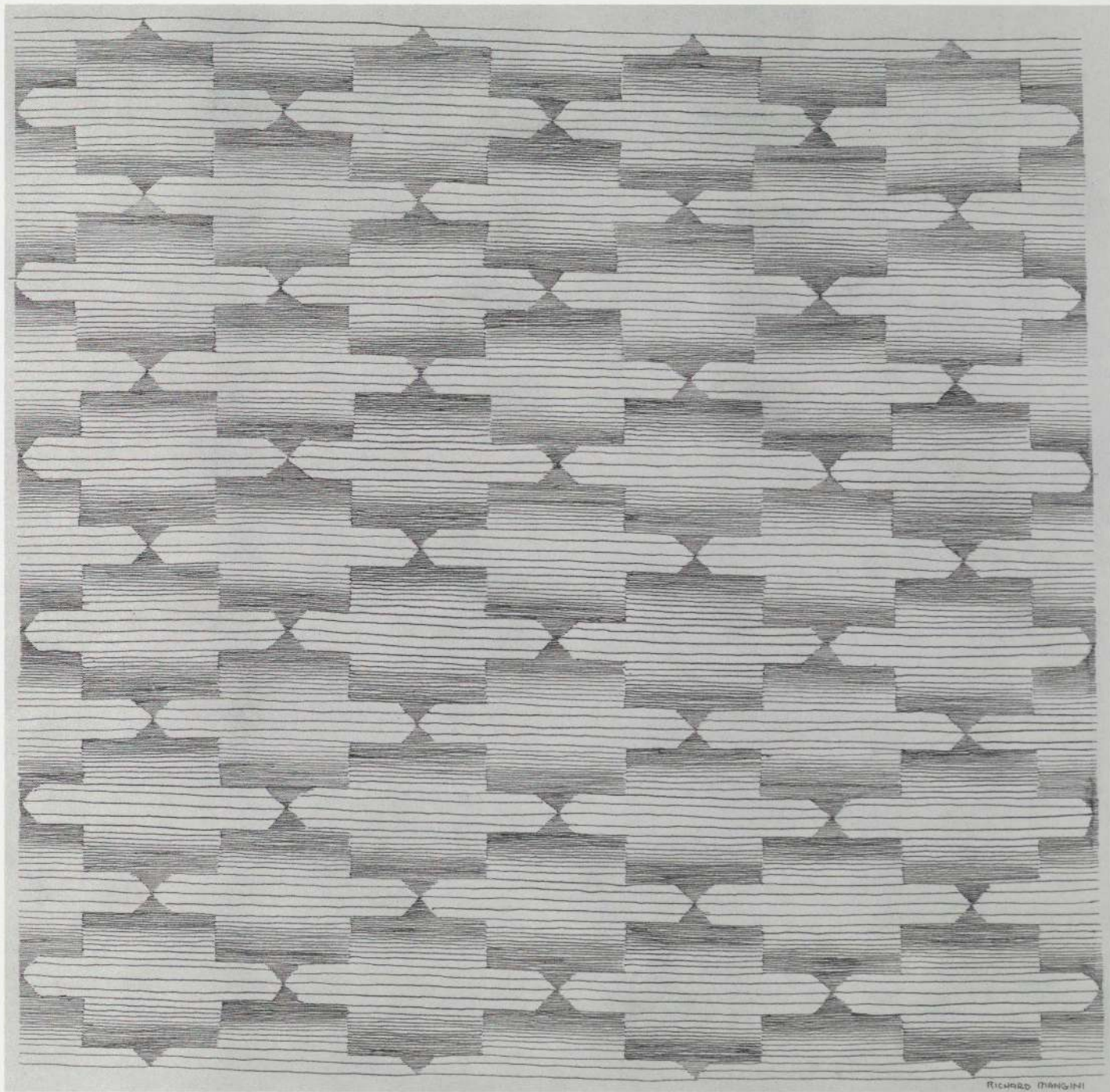

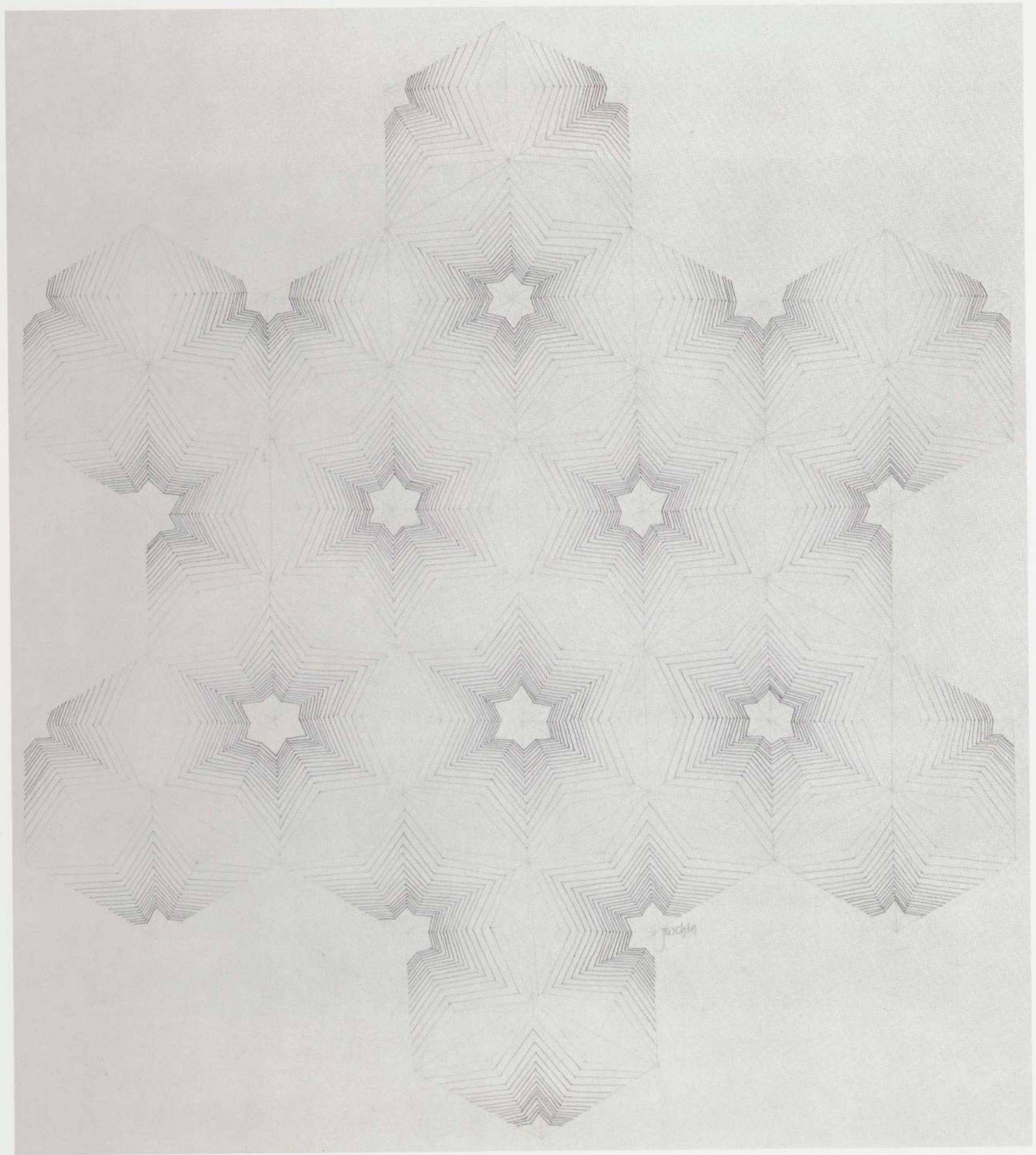



W. G. L. B. C. A.



Diana V. Georgescu

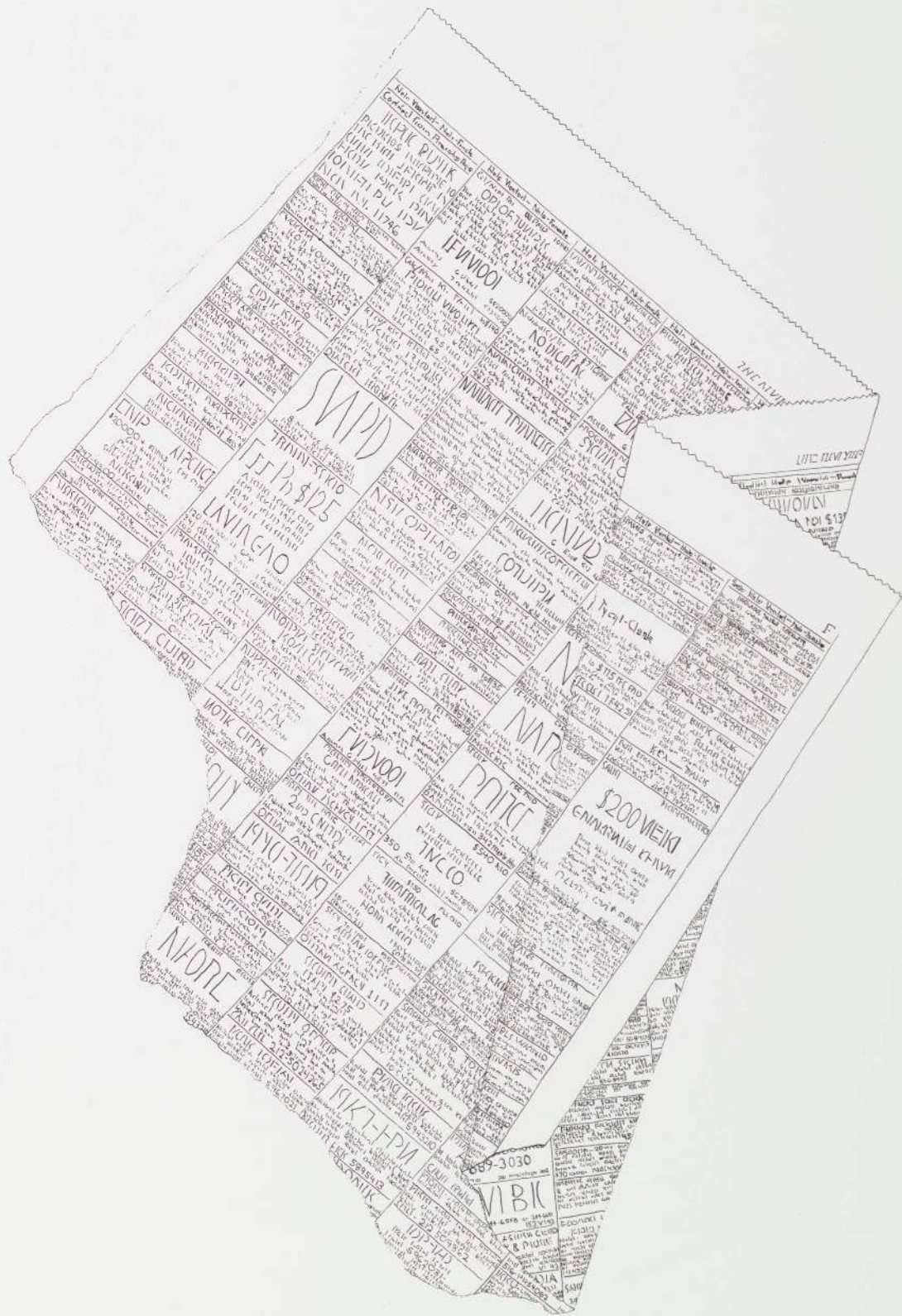

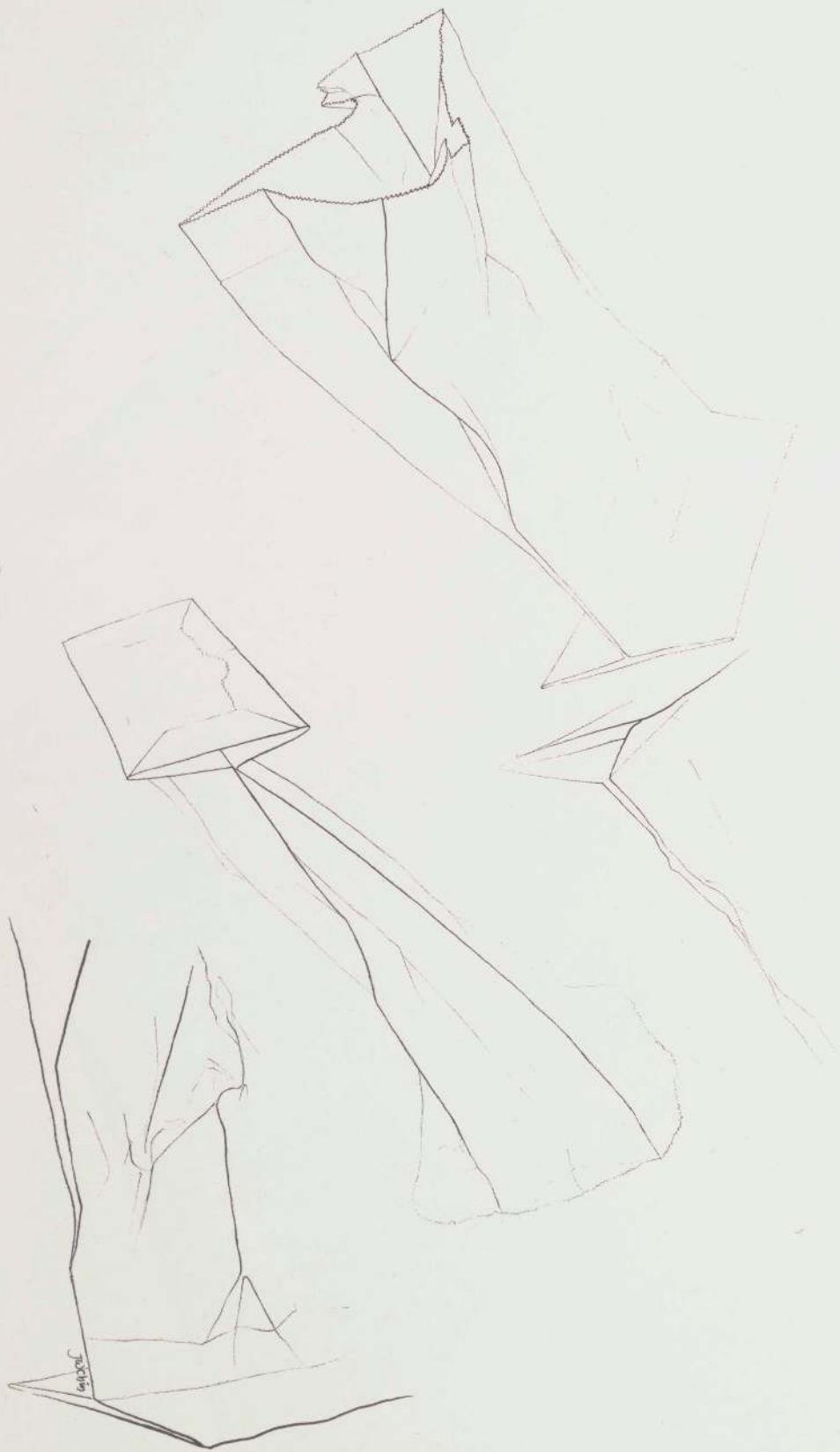





TWO-DIMENSIONAL/COLOR EXERCISES. The purpose of the course is to substantiate the concept of relativity within a fixed field of operations—in this case two dimensions. By observing this field, physically unmarked and undifferentiated in any way, certain energies arise in time which transform this actual space into a virtual one. This plane is presented as a formal device for the investigation of simple and complex configurations of flat, orthogonal origins. The energies of tension, compression, and shear—as well as concomitant energies of projective and recessive illusionism—are field qualities to be studied. For this to occur, the field must be seen as hermetically bound by taut edges, and distinct from its physical surround. It is a self-supportive field replete with energy patterns that shape, and are shaped by, any figural input. These color figurations, at first simple in number and shape, demonstrate the concept of pure plastic composition. It is with an increasing sensitivity to pictorial problems that lead to a less rigid system of pictorial variables, that more idiosyncratic elements (e.g. collage, montage) are introduced to this formal study. In a more profound sense, they may be viewed as paradigms to larger operations which include architecture and planning as well.

Robert Slutzky





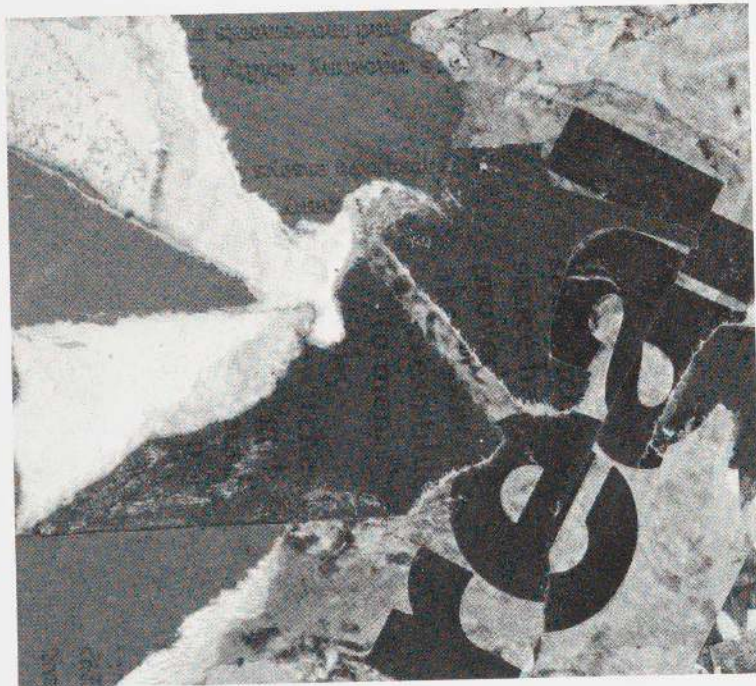

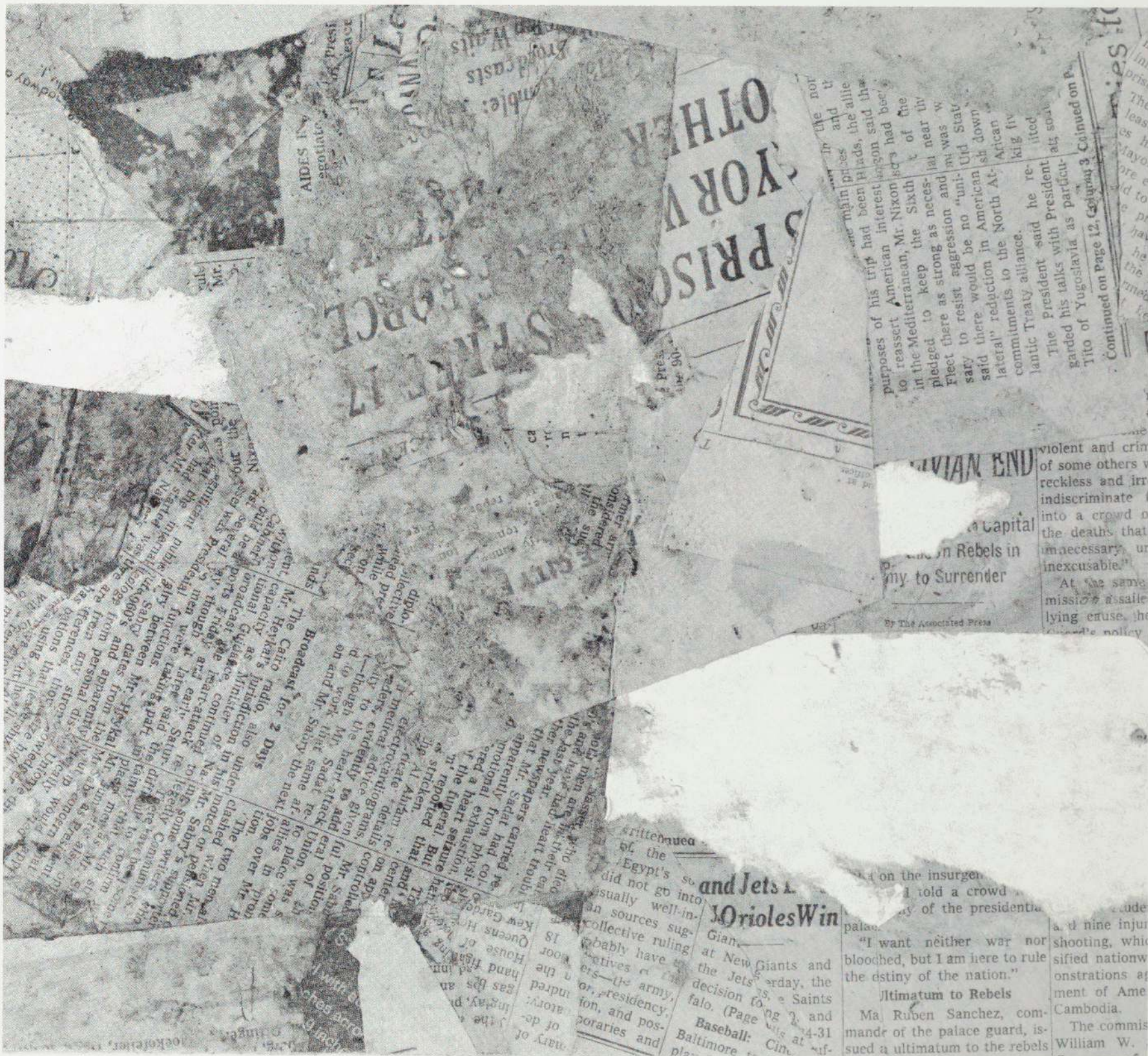

OTHER PRISONERS FOR V...

purposes of his trip had been in the Mediterranean, Mr. Nixon said. He pledged to keep the fleet there as strong as necessary to resist aggression and said there would be no "unilateral" reduction in American commitments to the North Atlantic Treaty alliance. The President said he regarded his talks with President Tito of Yugoslavia as particularly important.

Capital ... Rebels in ... to Surrender

violent and criminal of some others reckless and indiscriminate into a crowd of the deaths that unnecessary or inexcusable. At the same mission a salient lying eruse, the policy

Broadcast for 2 Days
The Cairo radio, also under the name of the Egyptian Broadcasting Corporation, broadcast a message from Mr. Heykal, Minister of Education, on Friday. He said that the Egyptian people were taking part in a struggle for freedom and independence. He called for a united front against the forces of imperialism and reaction.

Medical Details
The medical details of the attack on Mr. Sadat are being investigated. It is reported that he was struck by a bullet in the chest. The bullet is believed to have come from a rifle. The attack occurred in the city of Cairo. Mr. Sadat was taken to a hospital where he is receiving treatment.

Orioles Win and Jets

The Orioles won their game against the Yankees, and the Jets won their game against the Giants. The Orioles' victory was a significant one, as they had been struggling in the standings. The Jets' win was also a morale booster for the team.

Ultimatum to Rebels
Ma Ruben Sanchez, commander of the palace guard, issued an ultimatum to the rebels. He demanded that they withdraw from the palace grounds immediately. He threatened severe consequences if they refused.

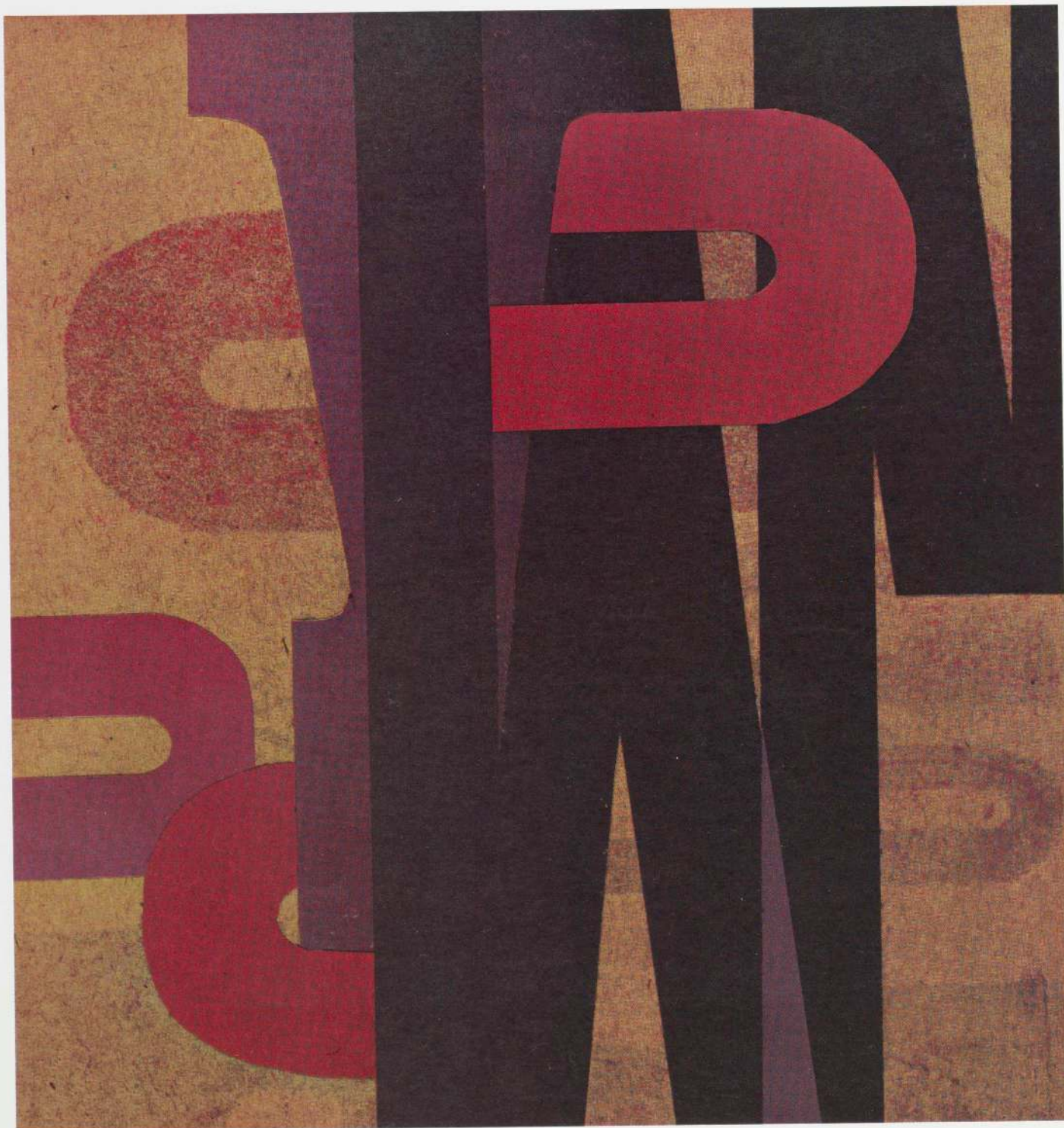

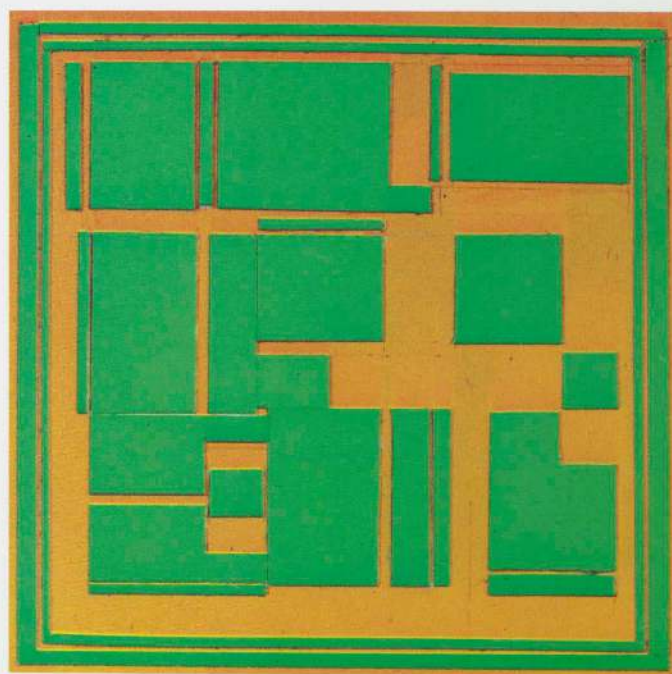
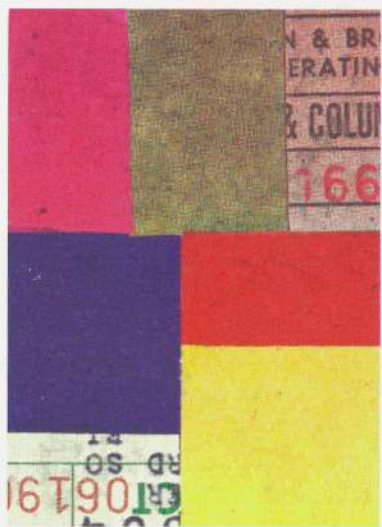

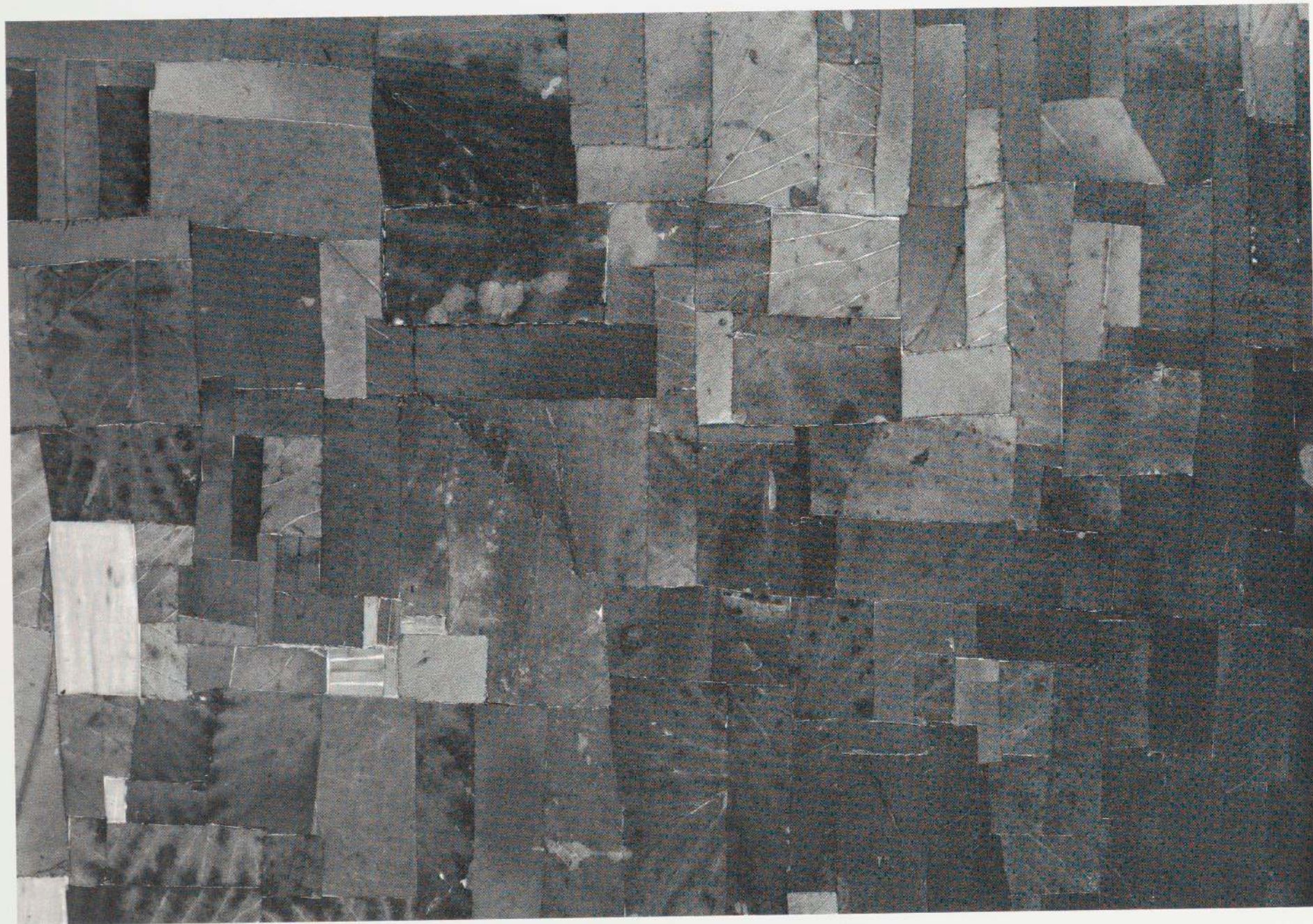

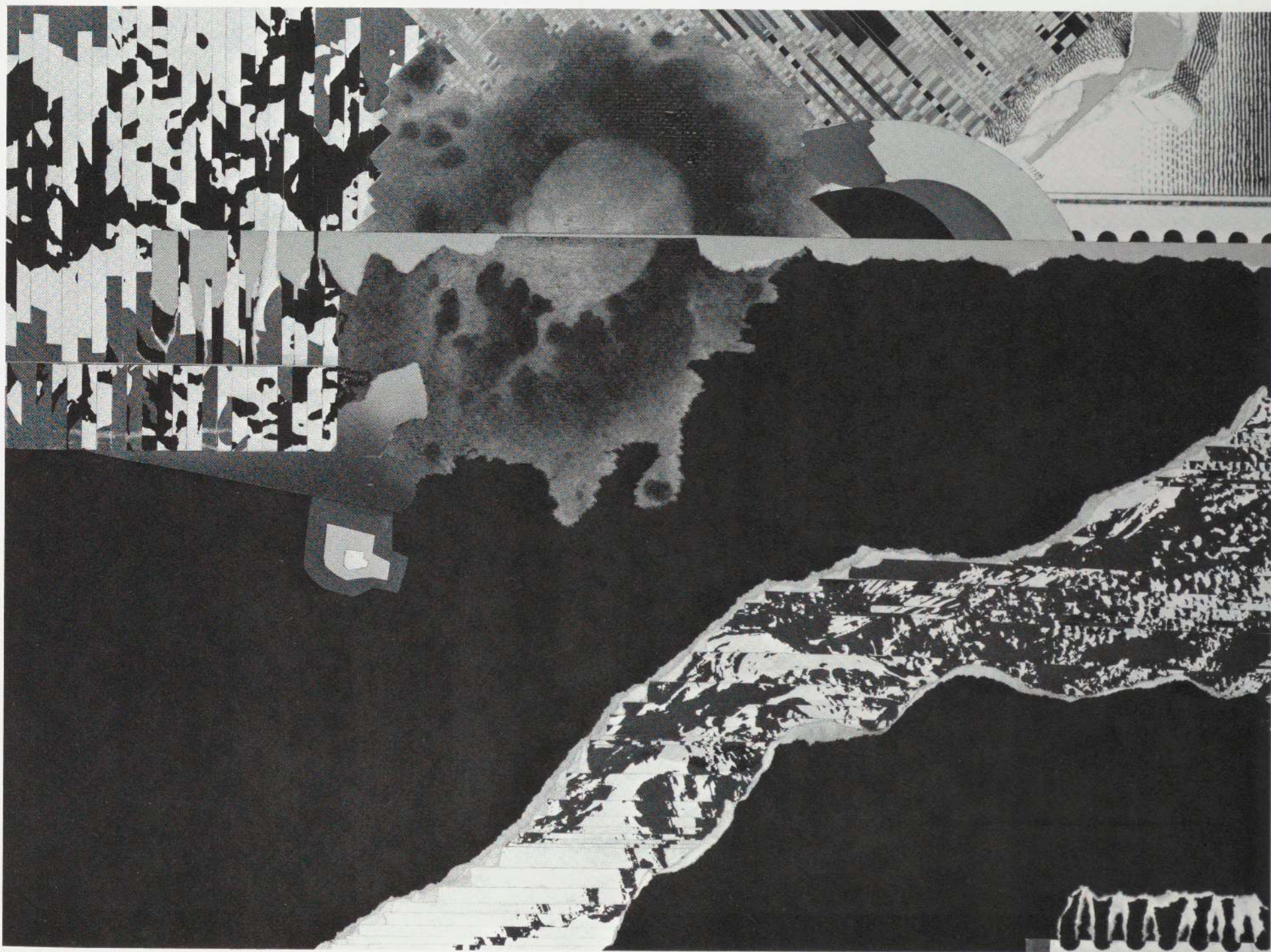

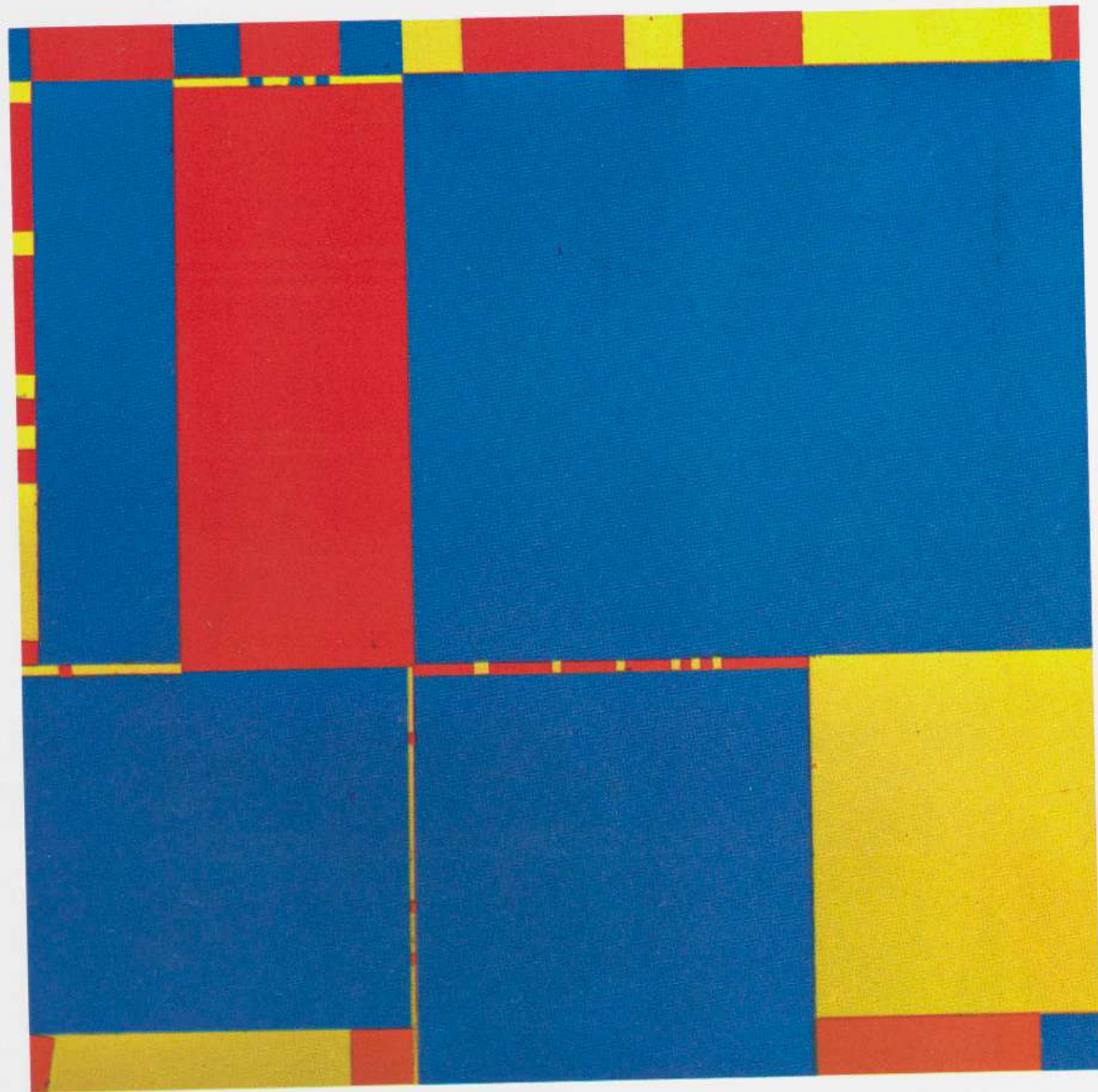

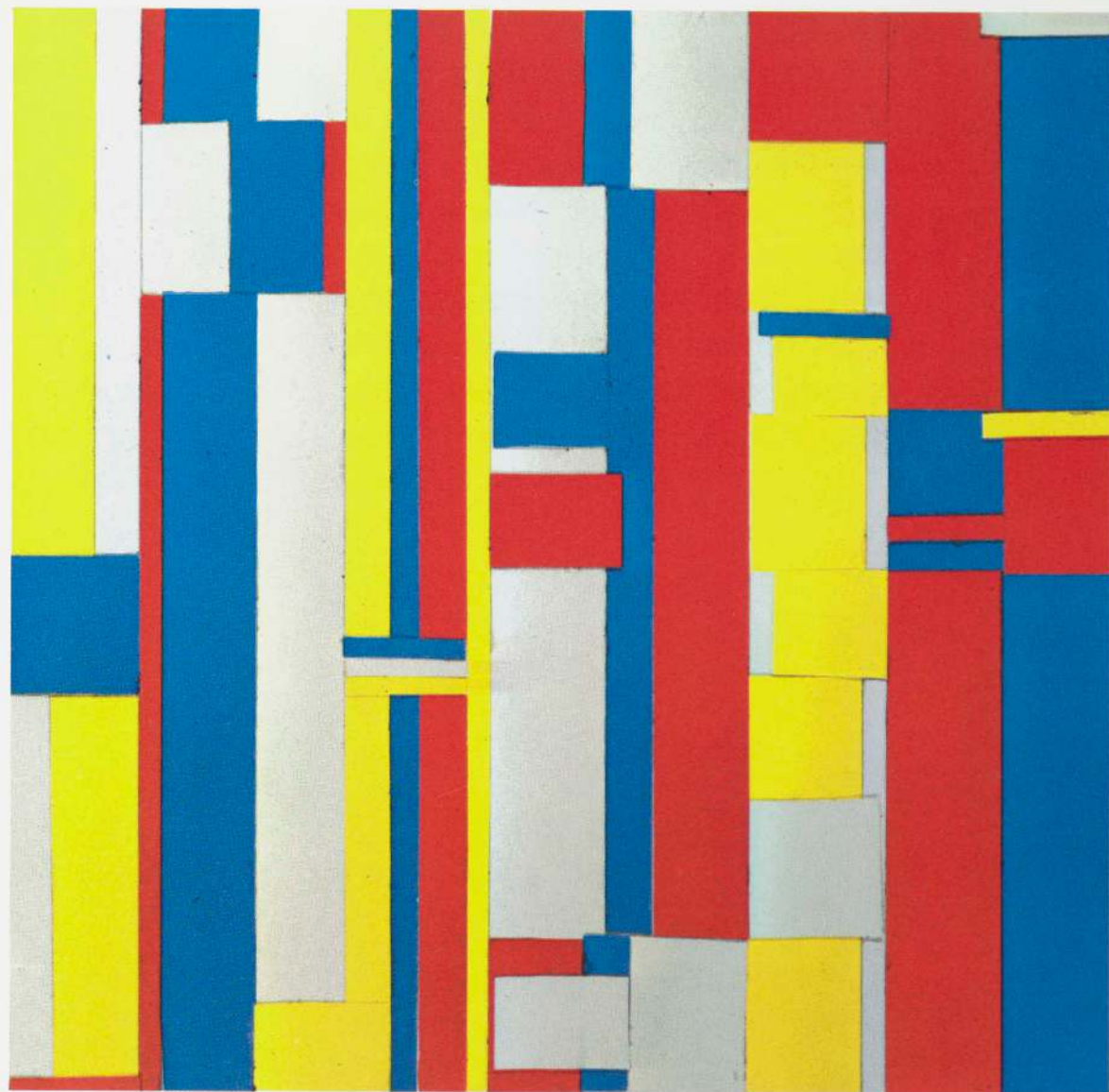



PROBLEMS OF DESIGN AND CONSTRUCTION.

This course is an introduction to the elements of construction. The student pursues an understanding of detailing in wood and masonry. Structure and controlled environment are studied as integral parts of architectural design. In all problems the project vehicle selected includes the development of a realistic program for an actual site, many times augmented by student research. Teams of students survey the site before any design work commences. A wood structure is given as a problem of investigation. The first insights of putting together wood members and the characteristics of wood as a material are revealed. Scale models are assembled, using every structural component as would be in the actual building. Full-scale typical joints from each project are constructed in the shops and a seminar is held to discuss the merits, faults and problems of each connection. If the problem so dictates, large scale construction sections are required from the roof through the foundation. Concurrent with the wood problem, the students research wood structures, as well as concrete, steel and other more exotic systems. This past year, a team of five students and one faculty member developed an experiment—a modular structure—and spent the Summer fabricating and erecting it on the Green Campus of The Cooper Union. This involved surveying the site, installing foundations, welding steel connections, milling lumber, experimenting with a polyester resin roofing system, and assembling the components. Parallel to the design course, a structures course is delivered presenting a qualitative examination of the forces acting on structures and the reaction of structures under load. The final project this past year was suggested by a student. The problem was put as, "Design a Utilitarian Object and Construct It." The objects included lamps, beds, chairs, shelving systems, and one electrically powered car.

Chester J. Wisniewski

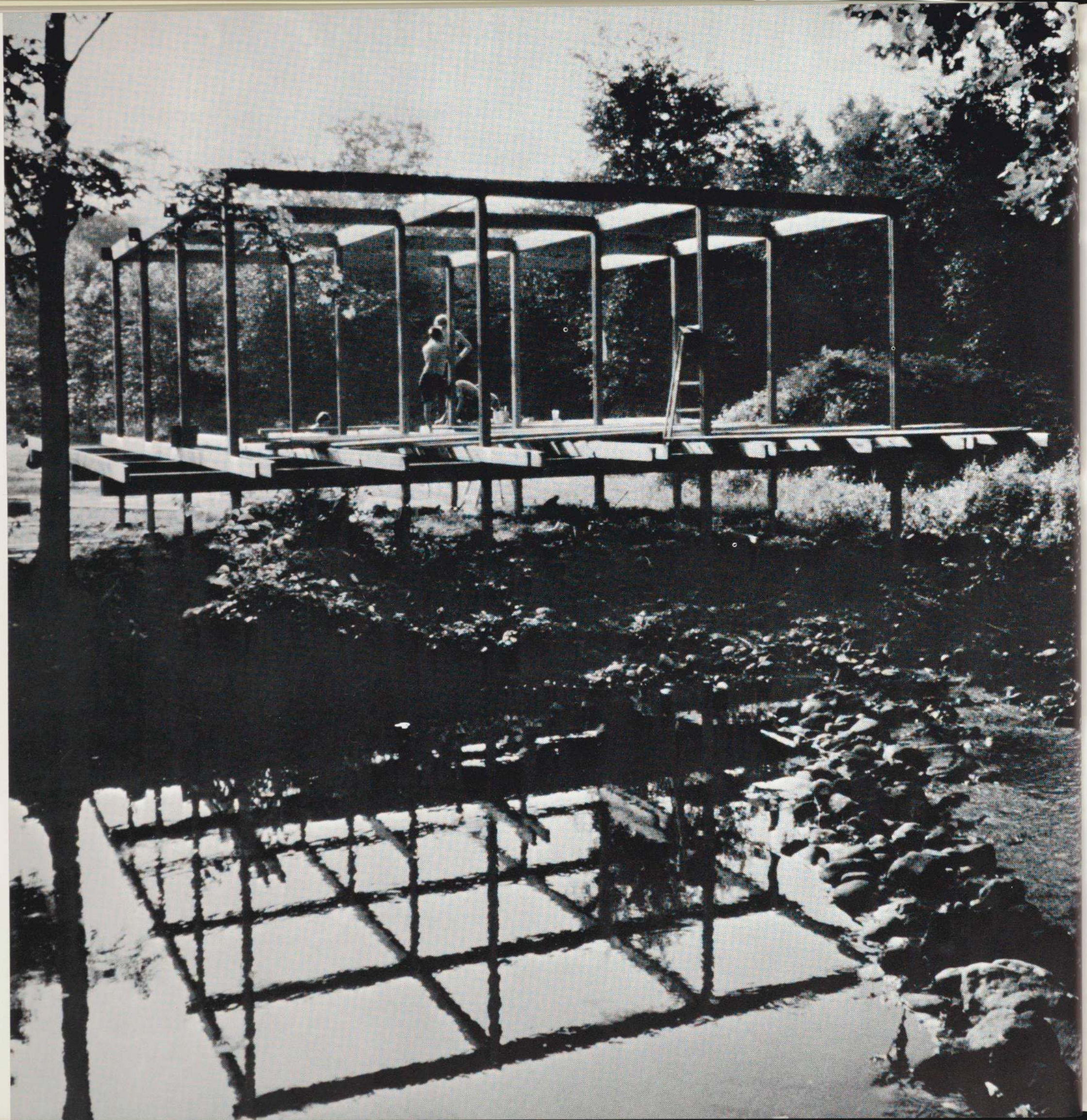

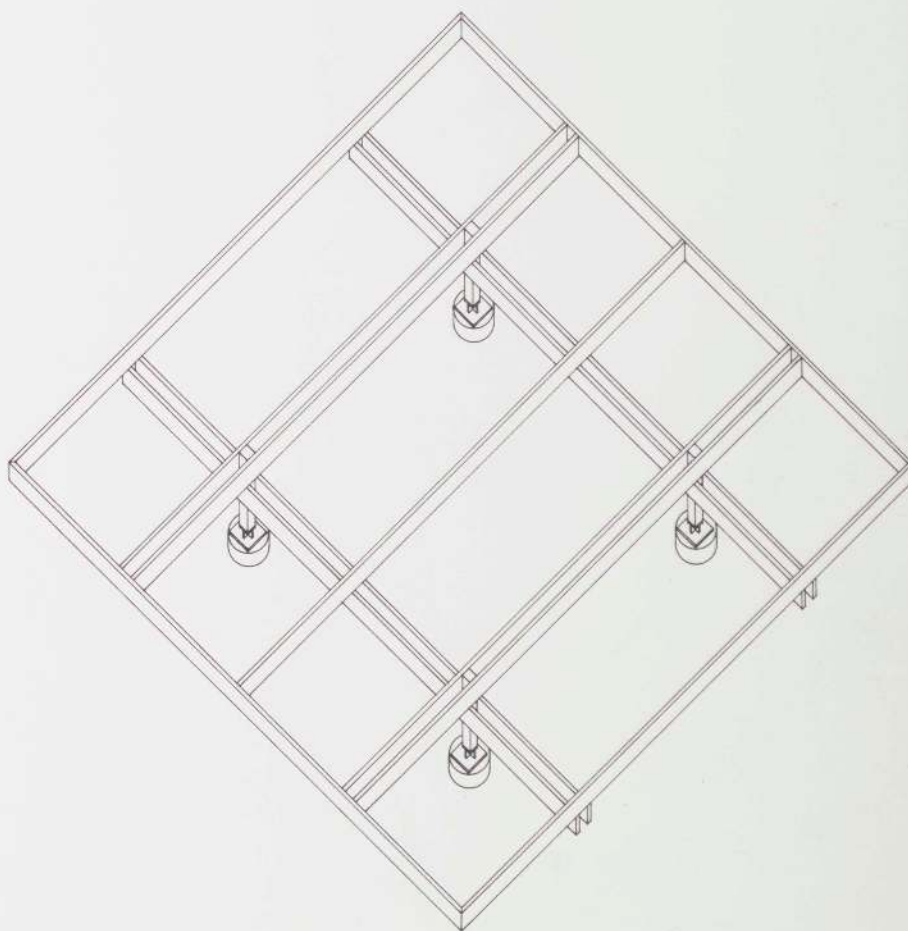

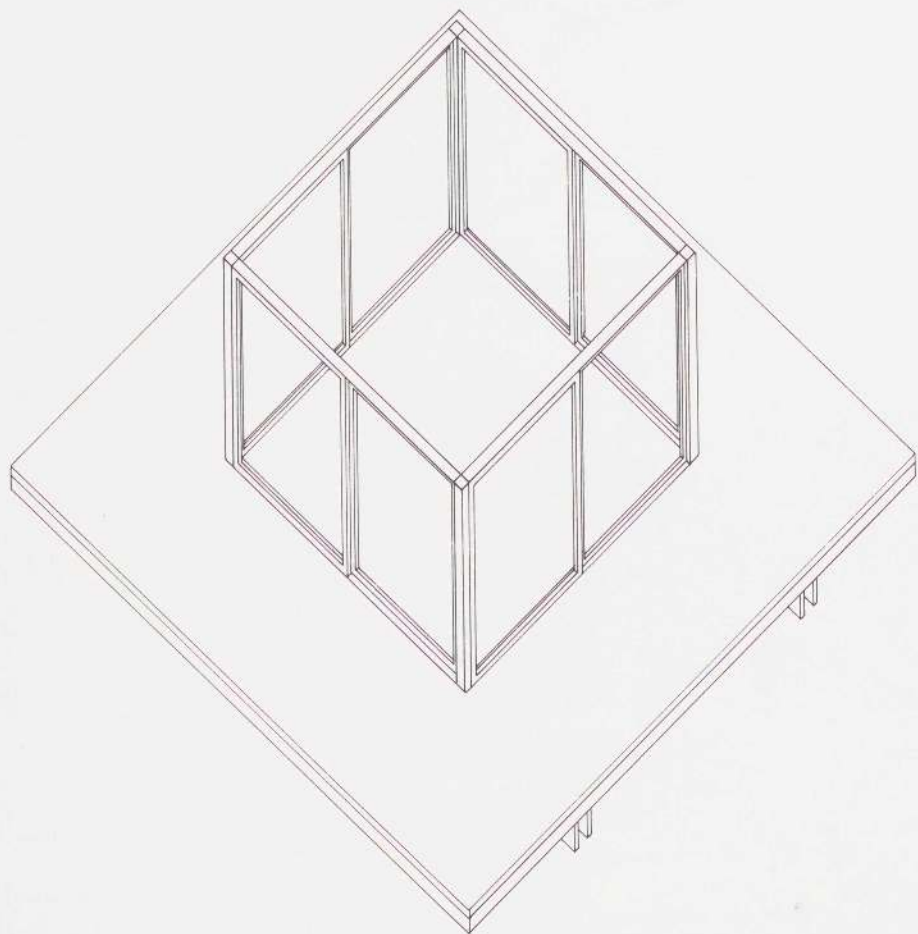
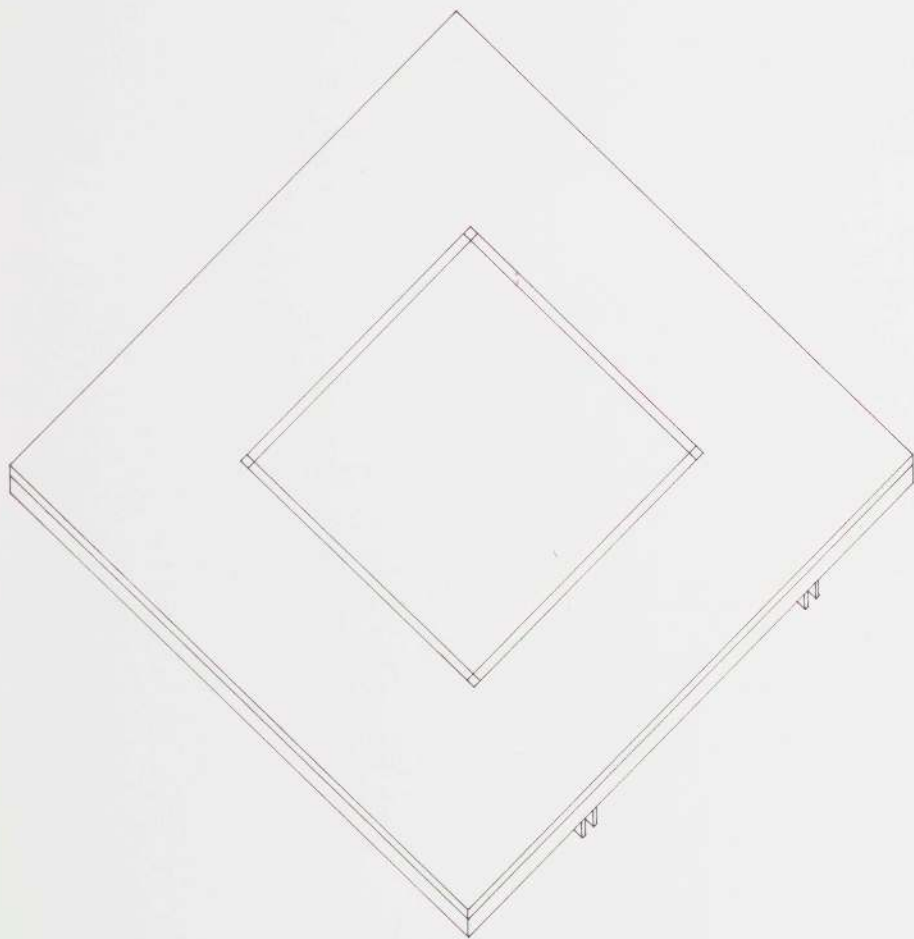

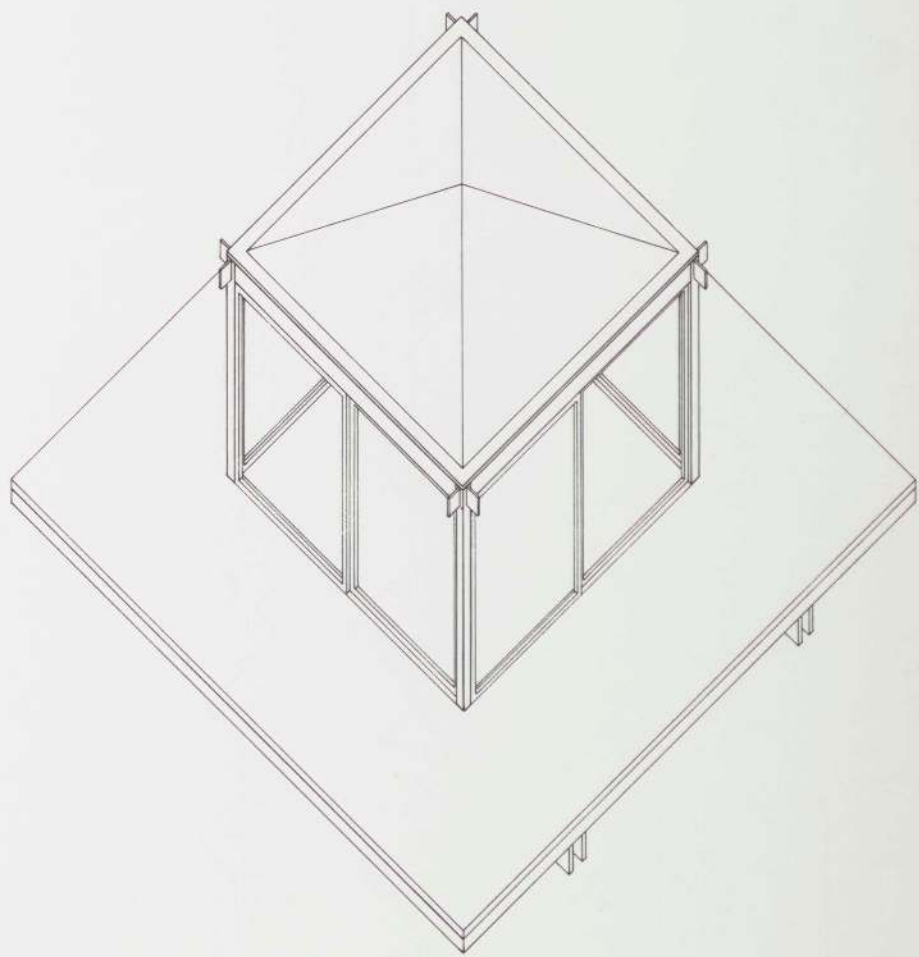
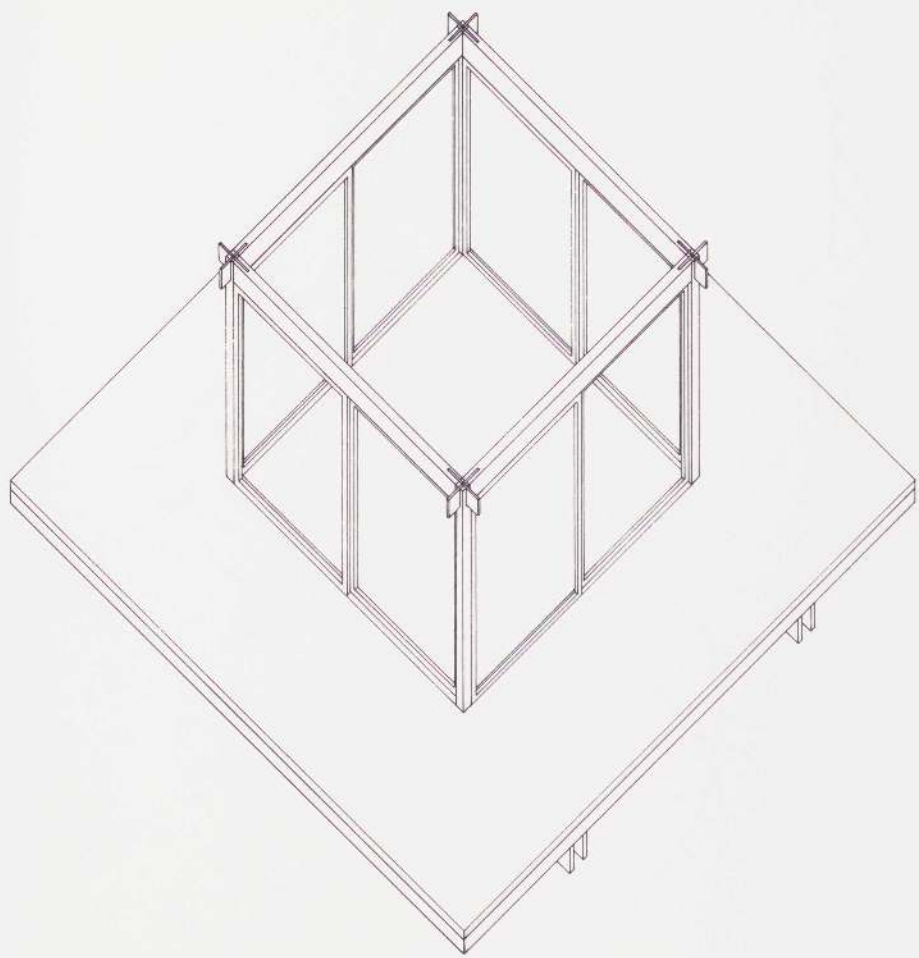

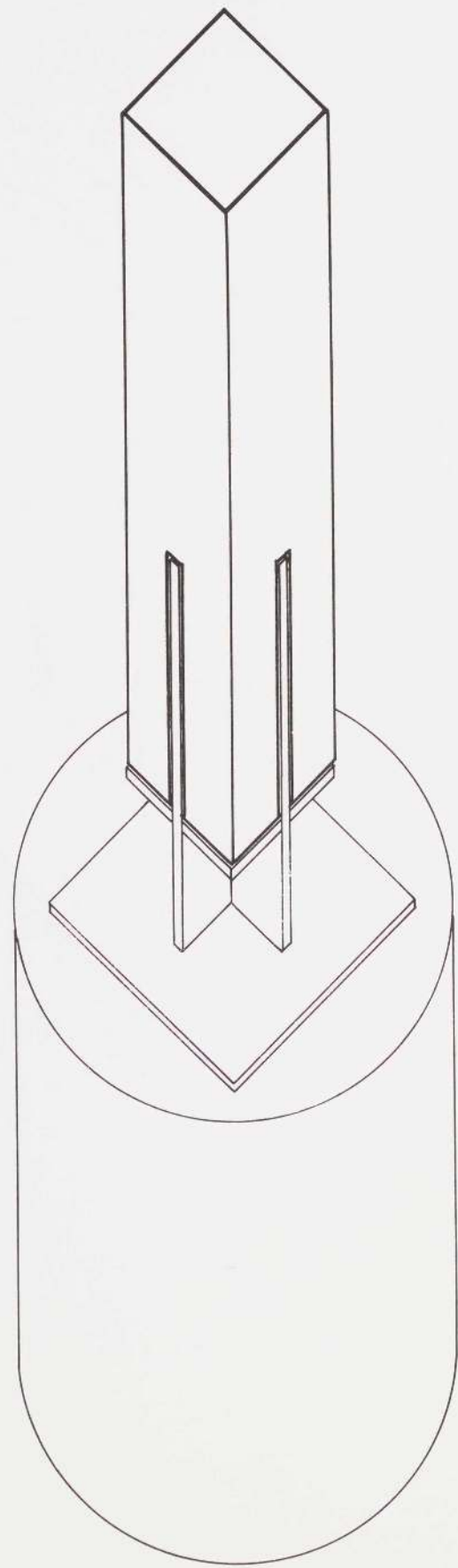
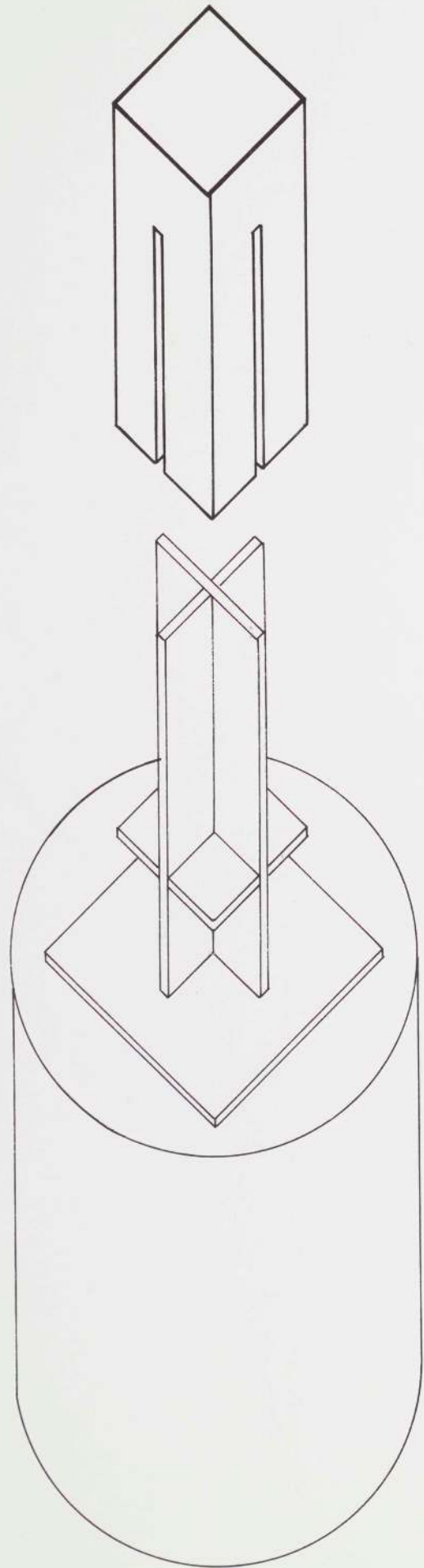

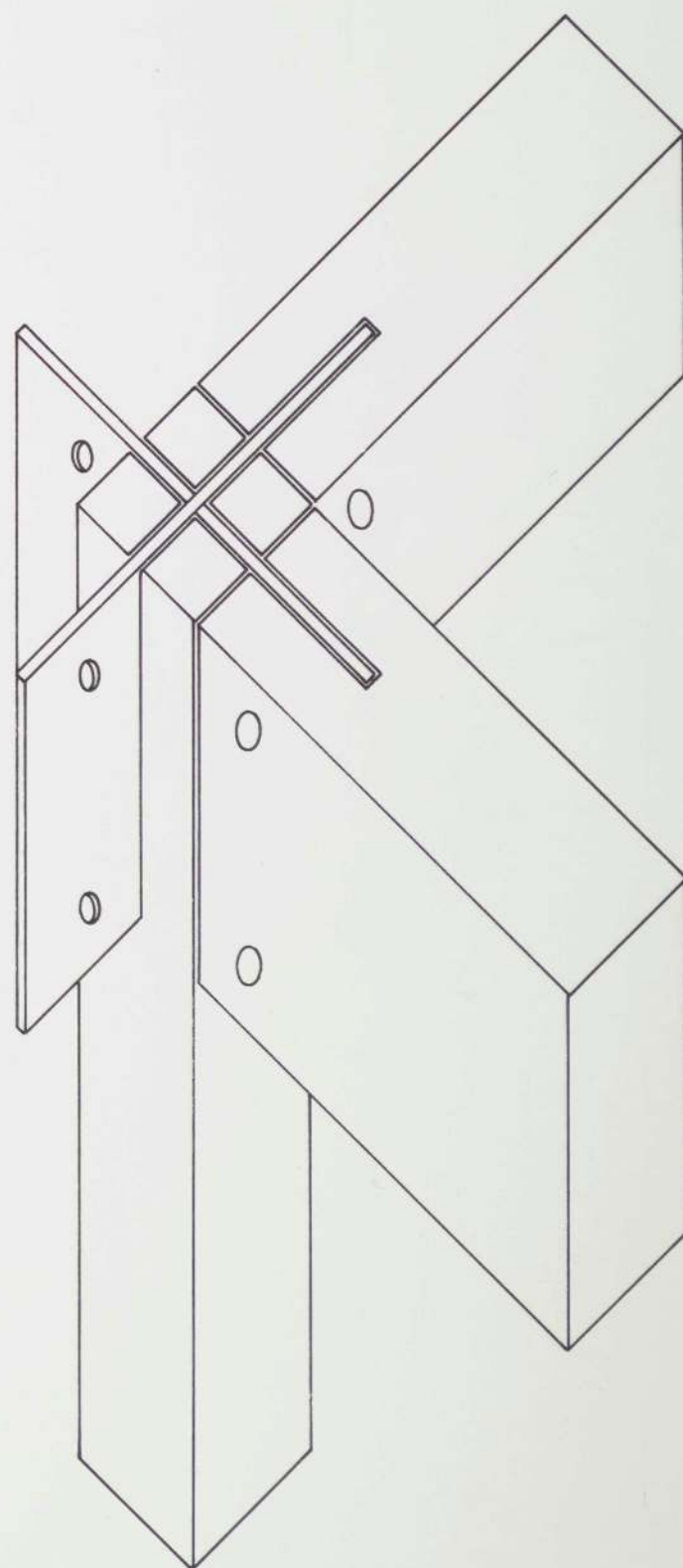
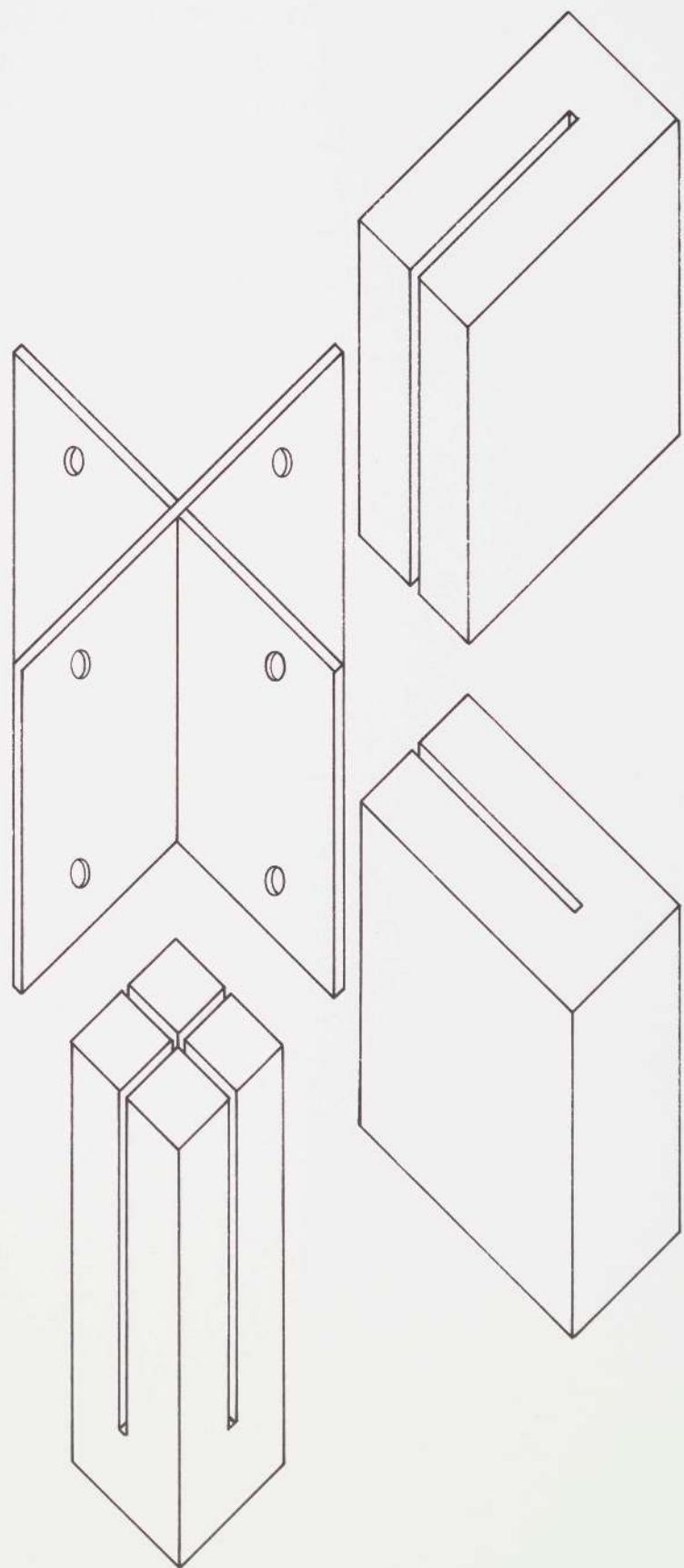

A GENTLE VEHICLE/PETER SAIITA. The assignment was to design and build a utilitarian object. Having already run the gamut of chairs, bookshelves and drawing boards I decided to design and build something which would reflect my metaphysical attitude and provide a bit more of a challenge. Now, two hundred dollars and six hundred hours later, I have (95% complete) a two-passenger, folding, three-wheel electric vehicle. Approximately, the specifications are as follows: length-101 in.; width-54.5 in.; width folded-26 in.; curb weight-200 lbs.; propulsion-2.25 hp, 24 v. DC motor; power source-two 12 v. storage batteries. Driving and steering is by the front bicycle wheel with a standard three-speed hub. Power transmission is through a thirty-to-one reduction gearbox to sprocket and chain. Motor control is by a foot operated on-off switch and a hand operated series-parallel switch providing either twelve or twenty-four volts to the motor and resulting in six forward speeds. The extreme maneuverability of the tricycle arrangement makes reverse unnecessary. The drive wheel is free when the motor is off and the resulting ability to coast, as in bicycling, extends the vehicle's range. Brakes are mechanical, to the rear wheels. Testing to date indicates a possible range of sixty to one hundred miles between charges and a top speed of twenty to thirty miles per hour.









PROGRAM-BUILDING PROBLEMS. The intention and obligation of such problems is to involve the student in the design of individual buildings of a size and complexity that are within his comprehension and within a context or setting that raises additional problems of environment, ecology, planning and historic continuity. By the time these problems are encountered, there should be enough familiarity with the vocabulary and implications of the building process that it is not necessary to begin a complete primary indoctrination program. Design knowledge, a dimensional and spatial credibility and an aesthetic philosophy are grounded in the building process. The relationship between a general schematic intent and the specific demands of a technology create interactions. Each modifies the other and produces insights that are seldom generated outside of the process of an individual's design. The course does not seek comprehensiveness. Innumerable building types are not studied. All the materials of building are not explored. The scope of programs is kept small. However, it is expected that what design work is done will be done in depth so that an approach to architecture can be developed and tested.

Richard G. Stein

STEEL FABRICATING PLANT/PAUL JOEL ROSEN. The solution does not attempt to invent or discover new or more efficient methods of producing fabricated steel members. Accepting the existing means of fabrication, the solution becomes involved with the form and disposition of the various given elements of the fabricating process. The visual energies required of the spaces and elements, along with the dynamics inherent in each stage of the fabricating process, have served as a basis for the design which clarifies and enunciates the individual and group areas of function. Fabricated, braced columns supporting the craneway run continuously from incoming to outgoing storage yards, passing through enclosed shed areas constructed of mullionless glass channels. The administrative and support facilities include an exhibition gallery, lunchroom, locker room, an equipment repair and storage bay, and office space. The upper two floors of this building are screened by glass block of three different sizes. The ground-level exterior is enclosed with concrete block.

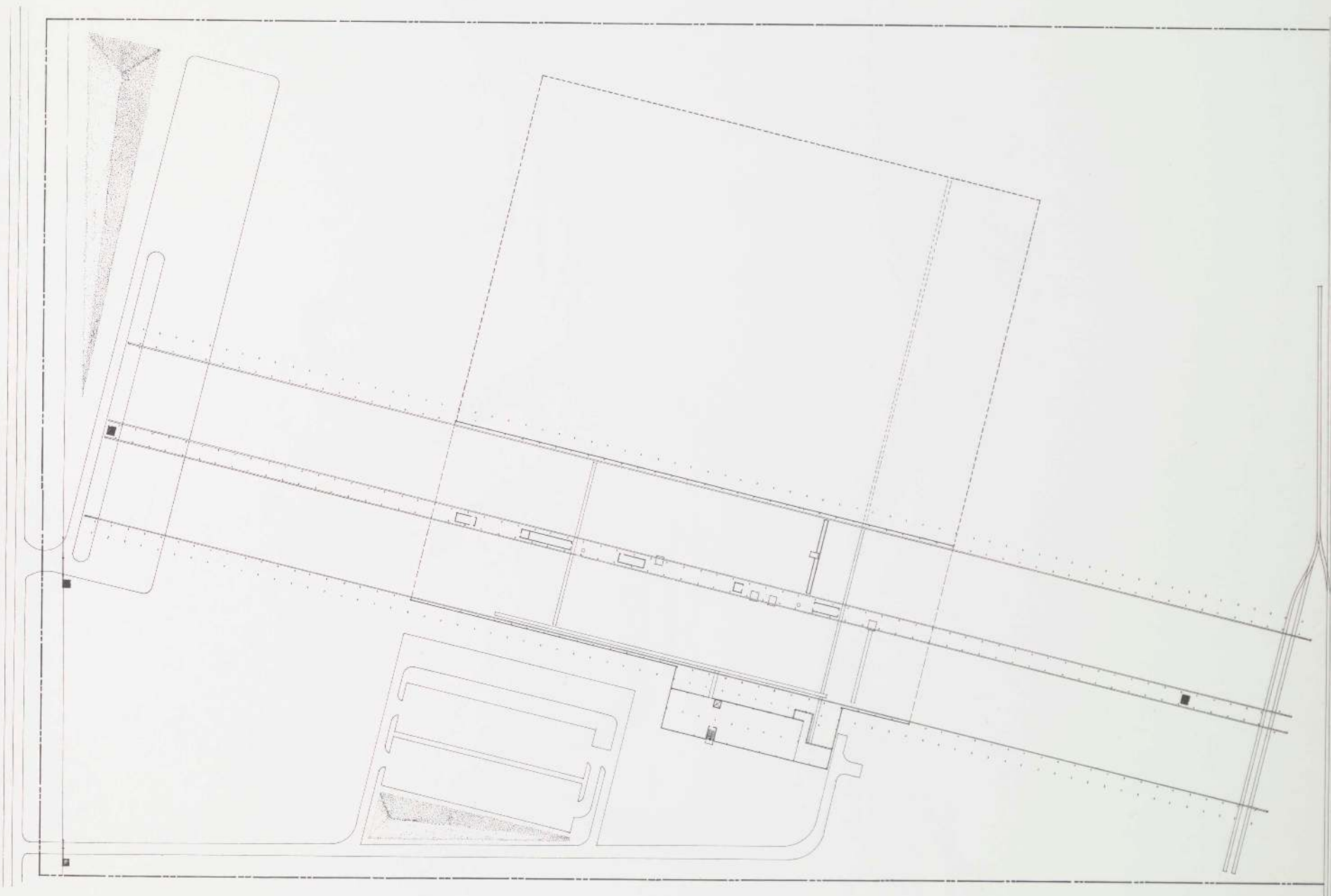



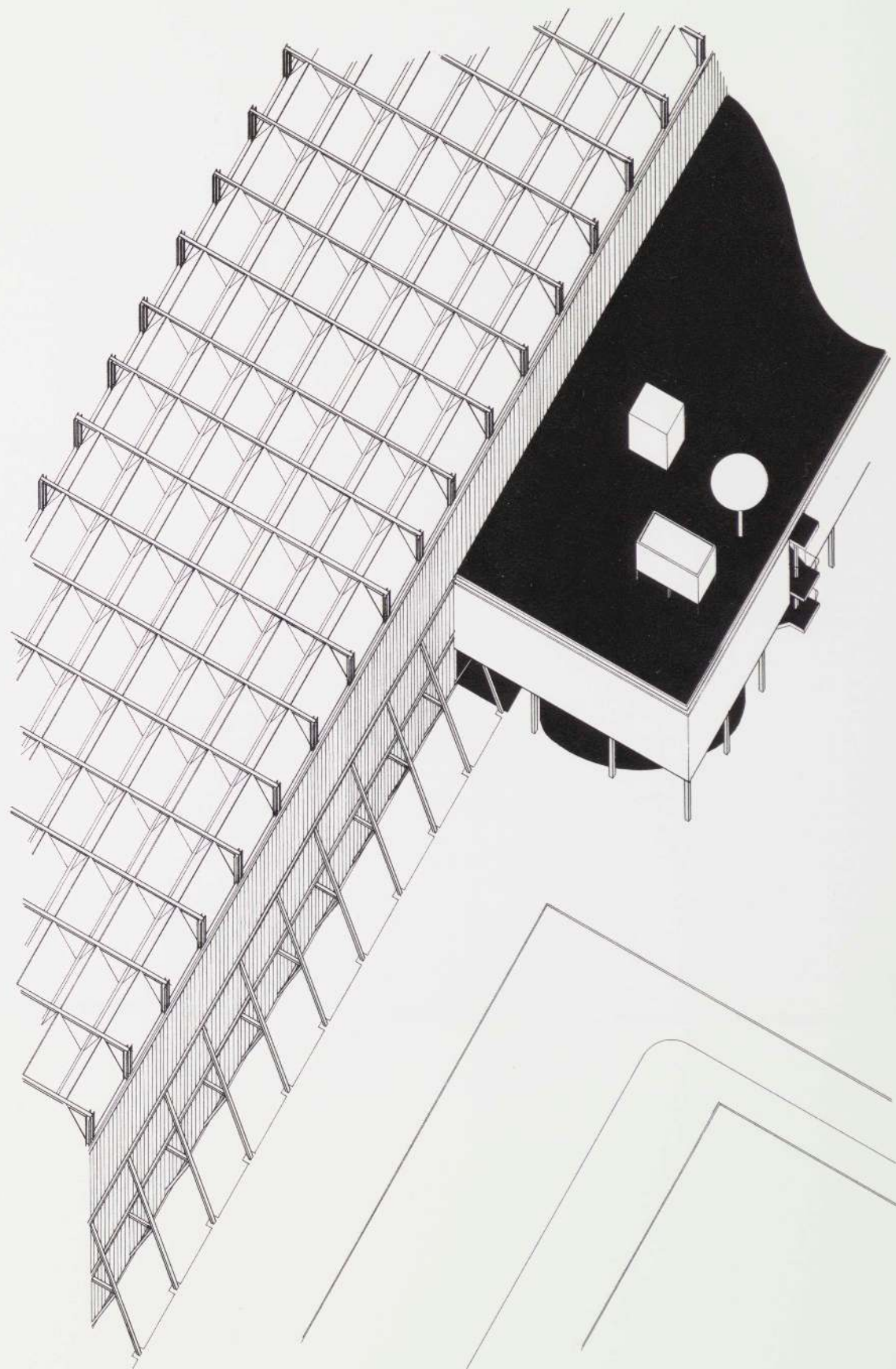

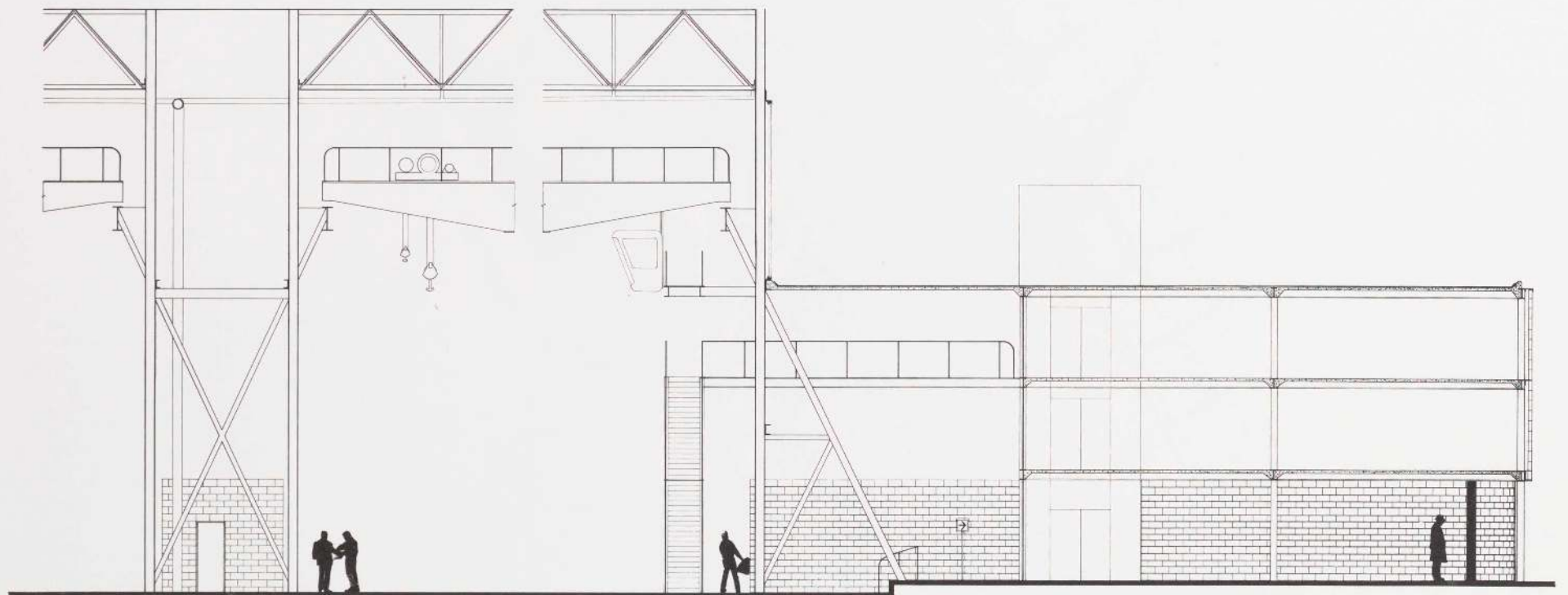



URBAN HOUSING/DANIEL LIBESKIND.

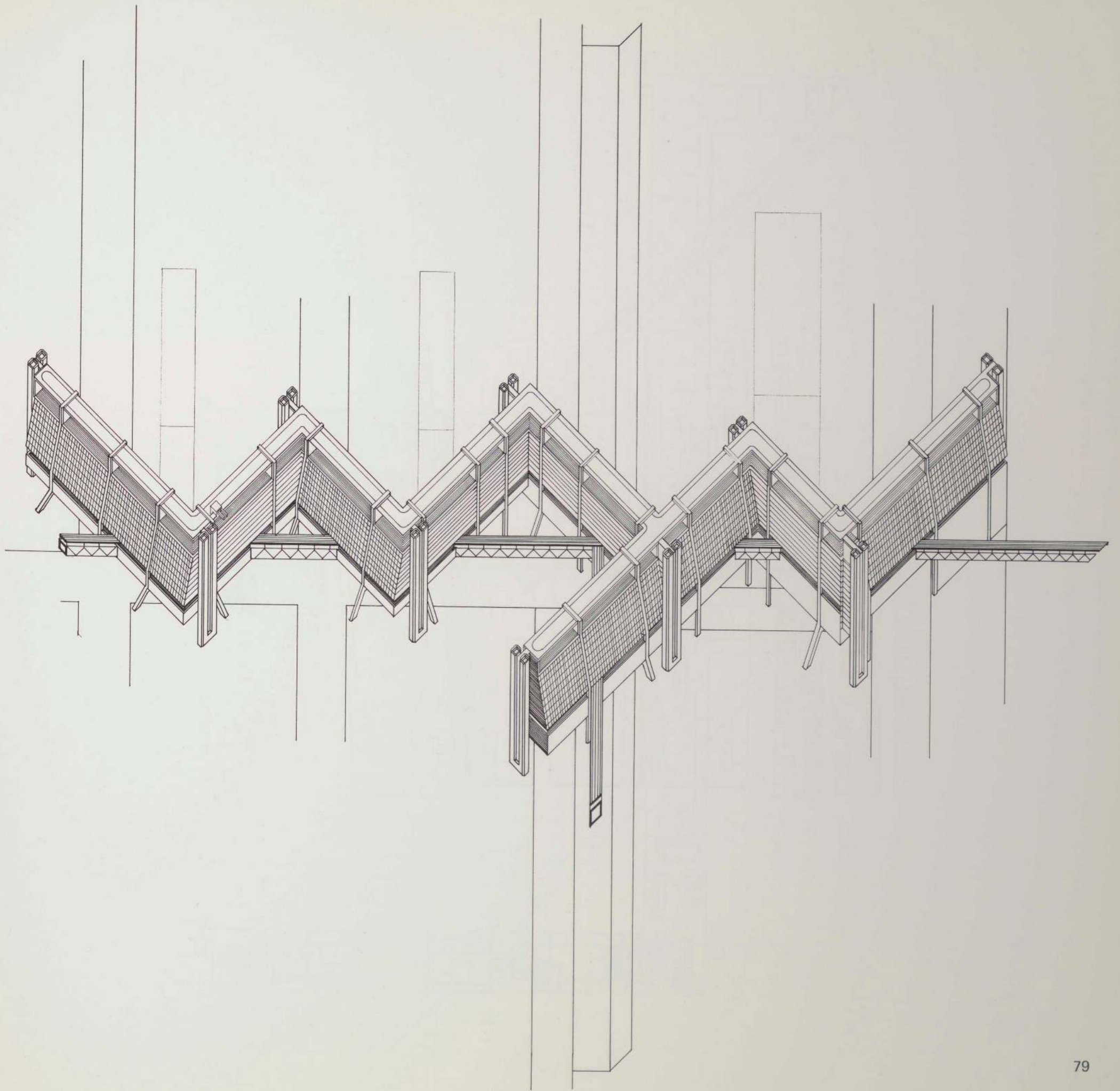

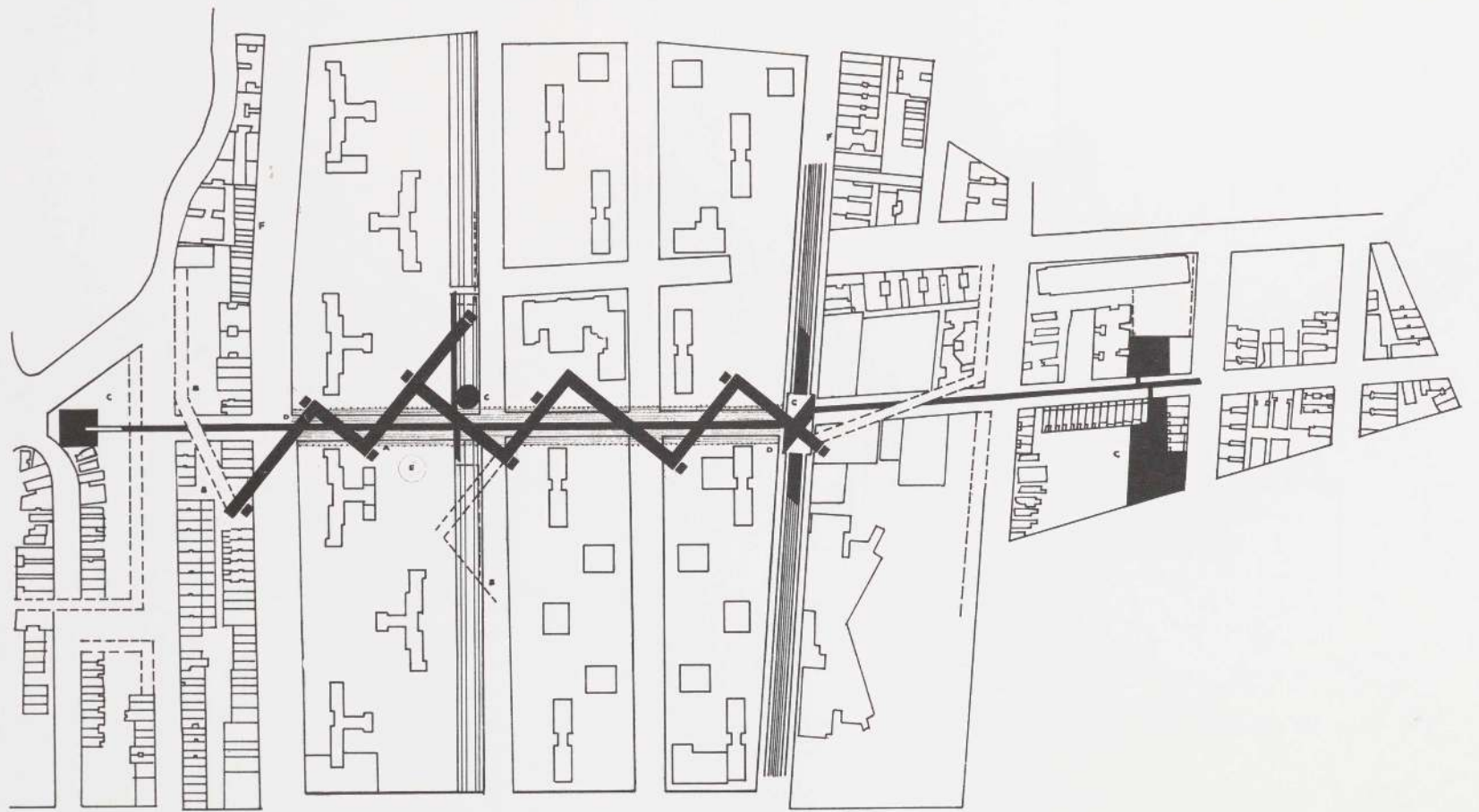

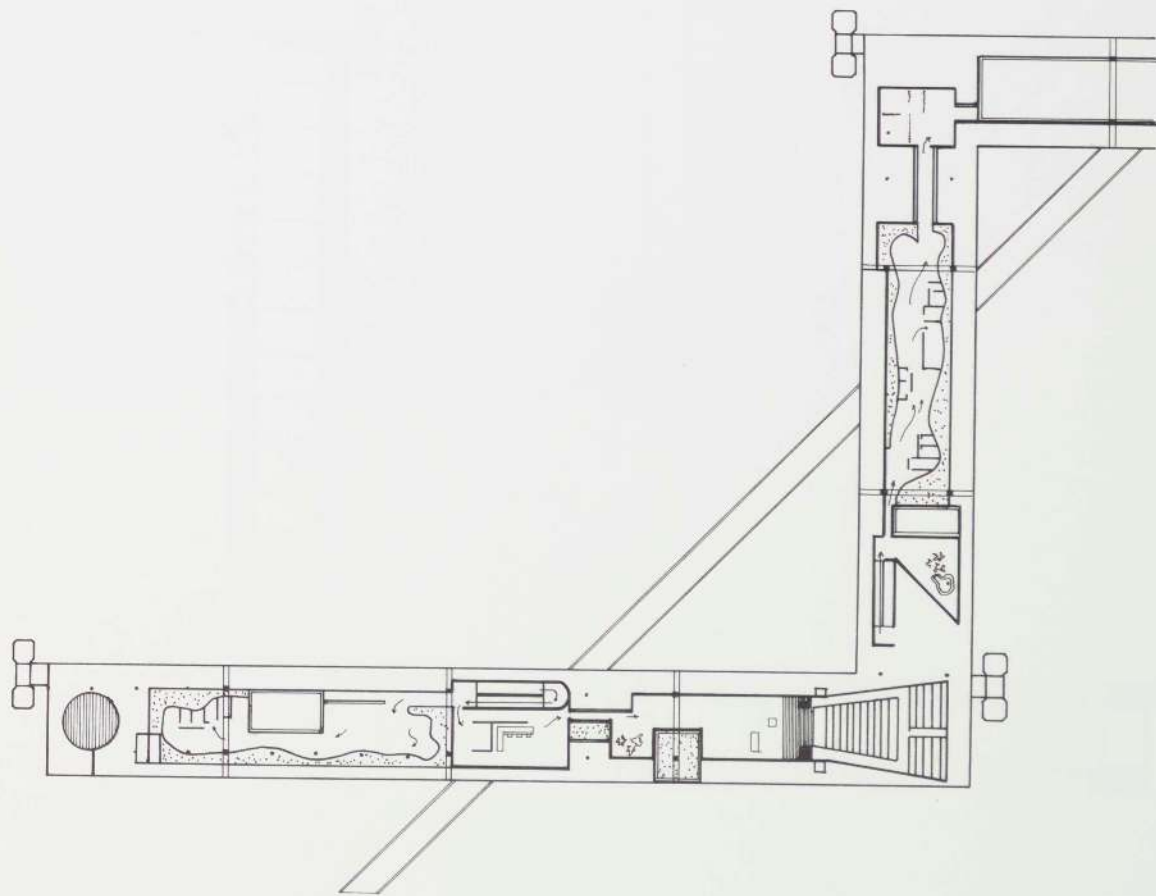
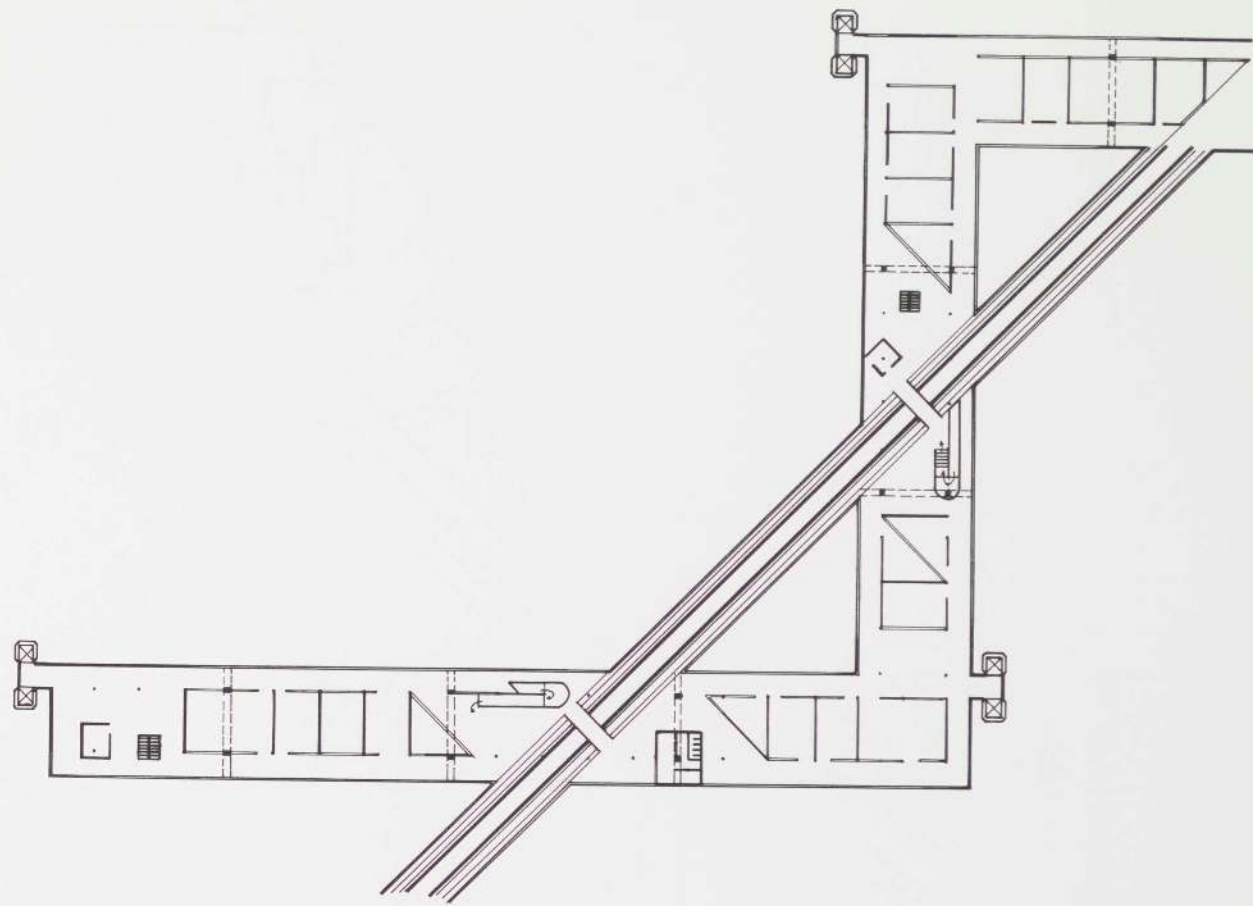

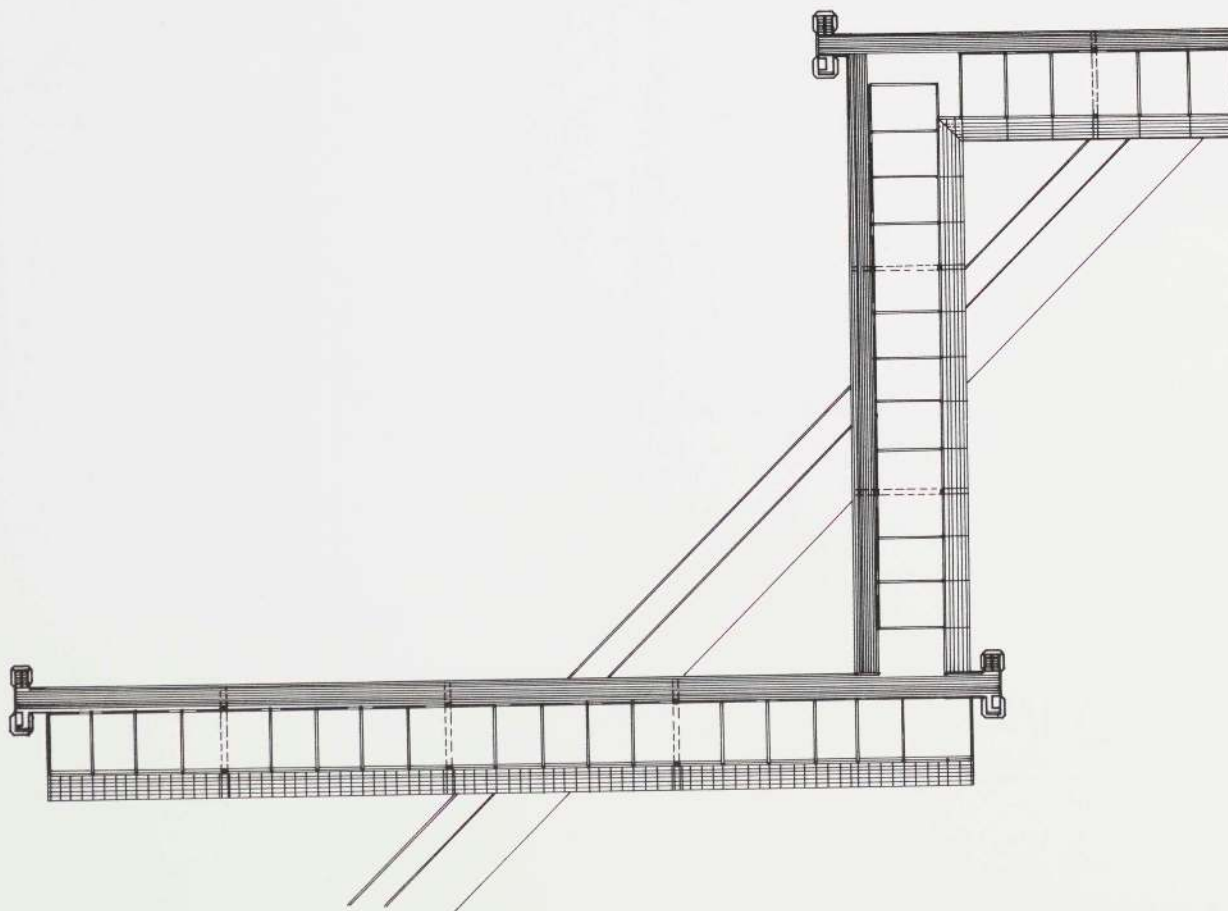
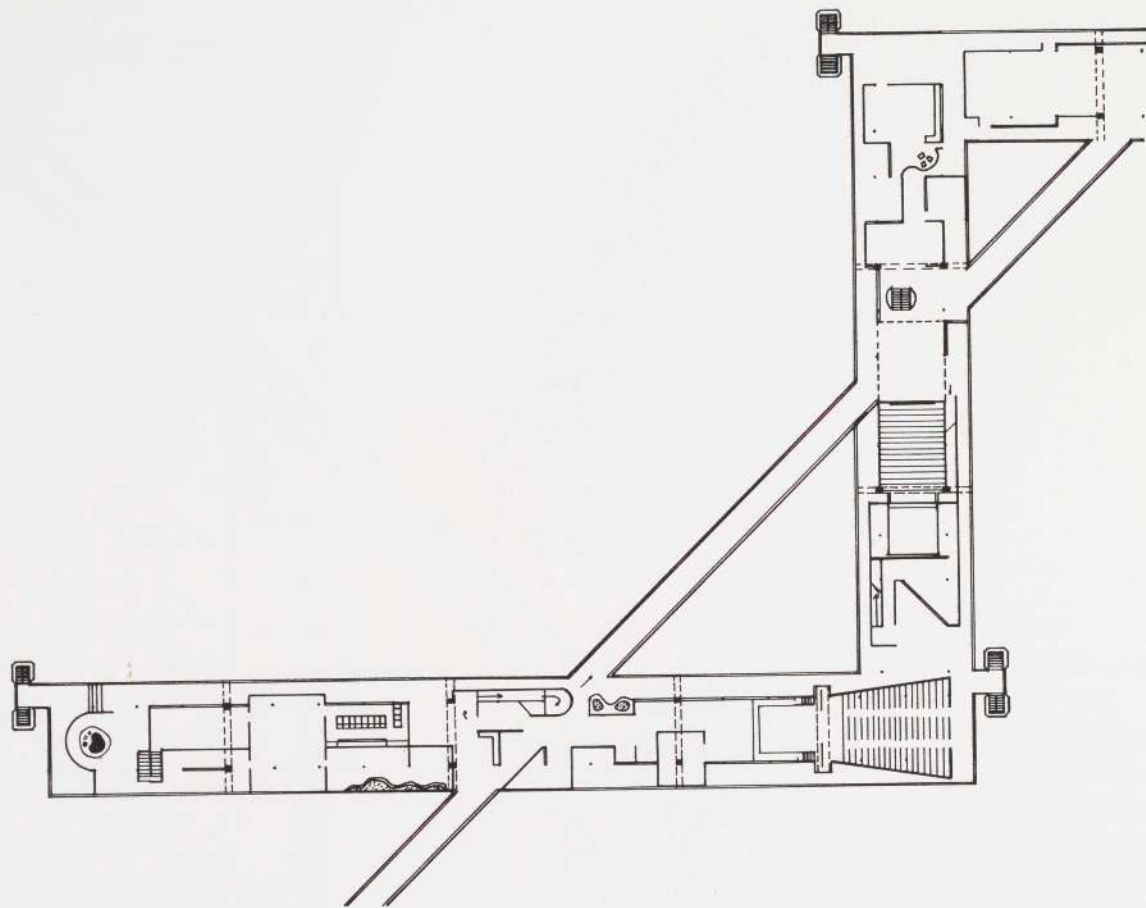

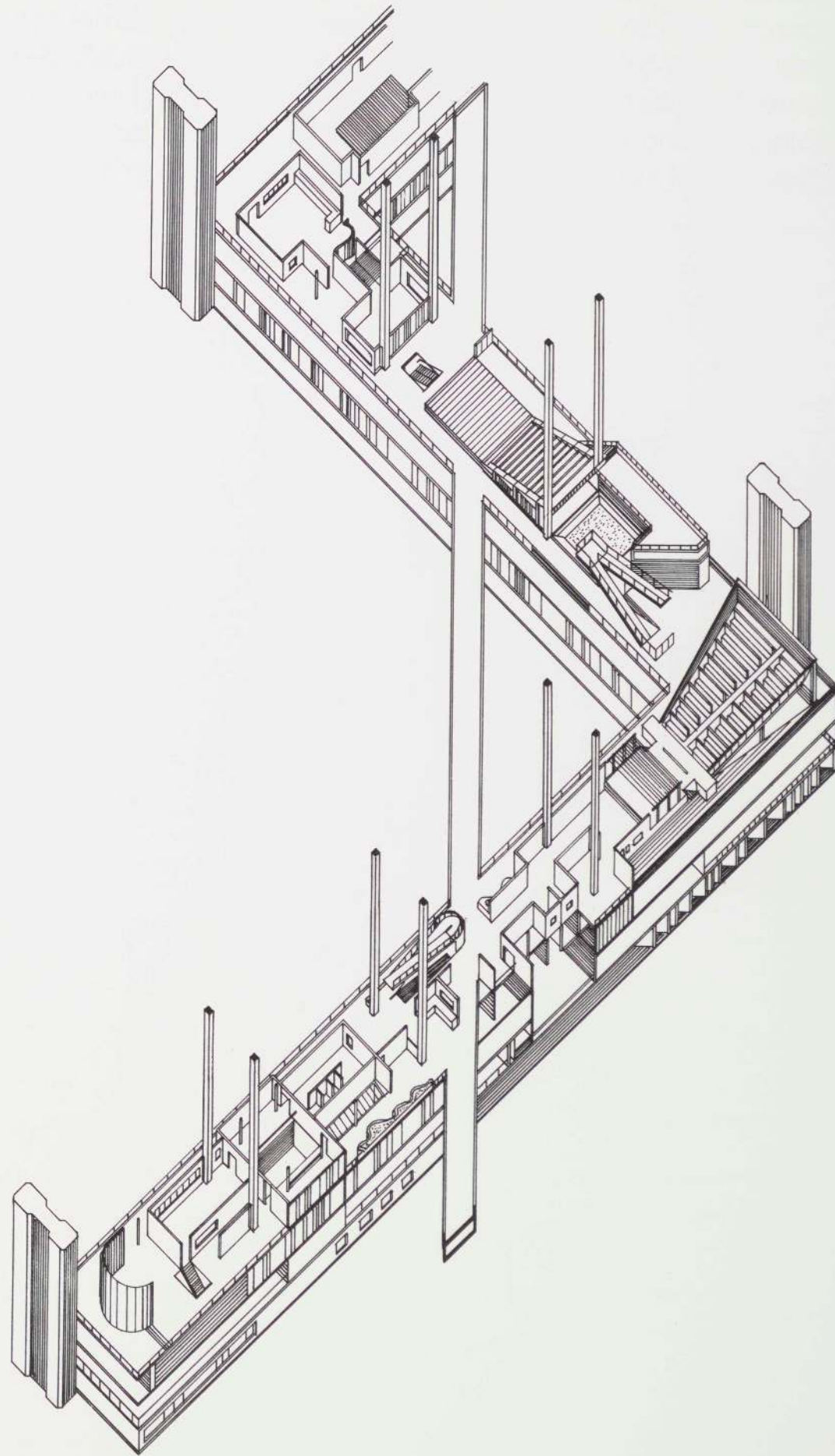

COMMUNICATIONS CENTER/CARMI BEE. The objectives. One: to determine how the problems arising from the complex interaction between students and machines could be resolved in such a way as to enhance the learning experience. Two: to create a system of internal and external activity areas which would serve as a coagulant in developing a coherent campus plan out of a previously dispersed and amorphous situation. Three: to investigate the extent to which Aalto's personal design idiom could be expanded and applied to architectural problem-solving at large. Specifically, I was interested in investigating the approach he used in organizing complex sets of spaces and activities in a building such as the Wolfsburg Civic Center.

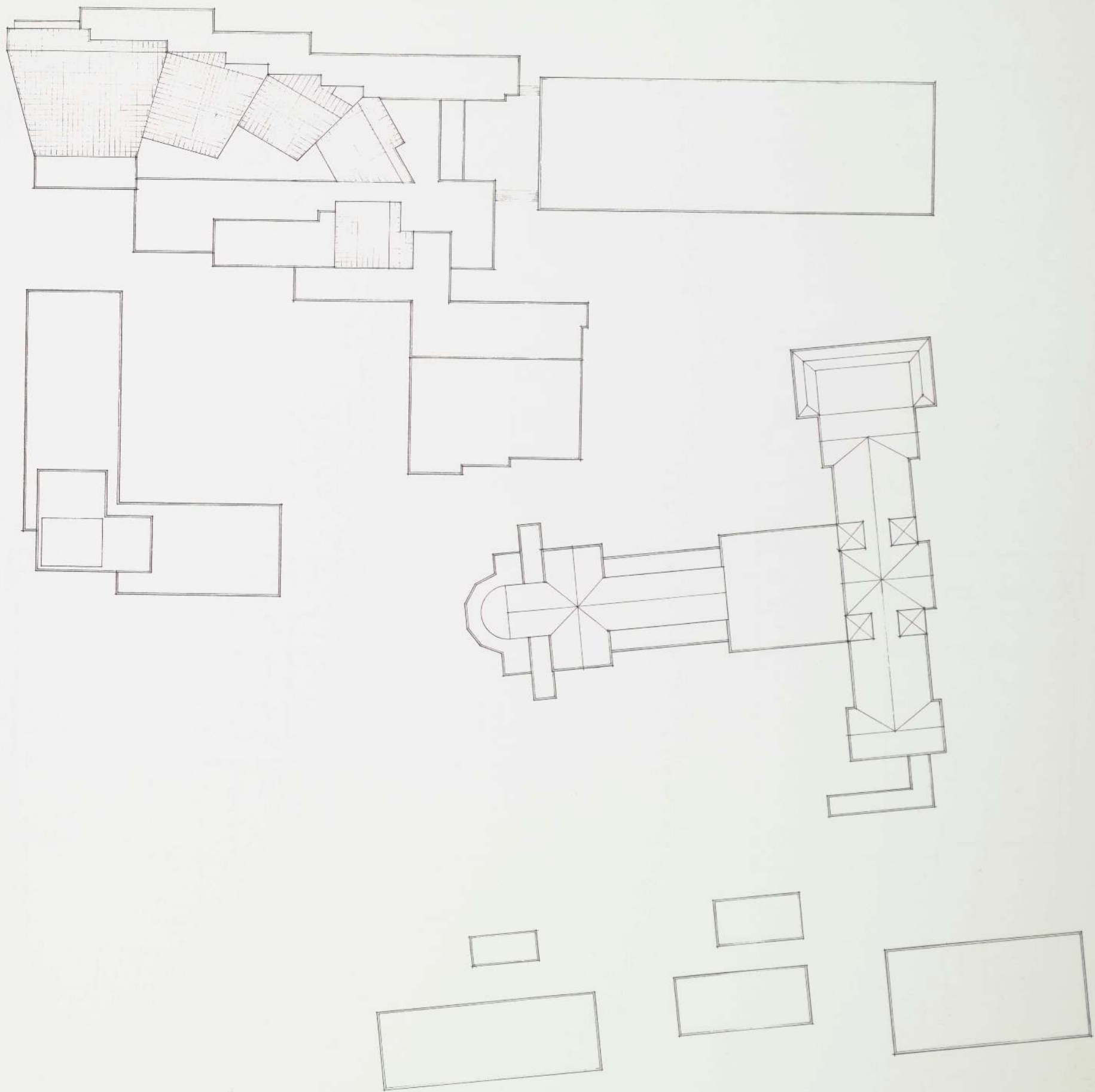

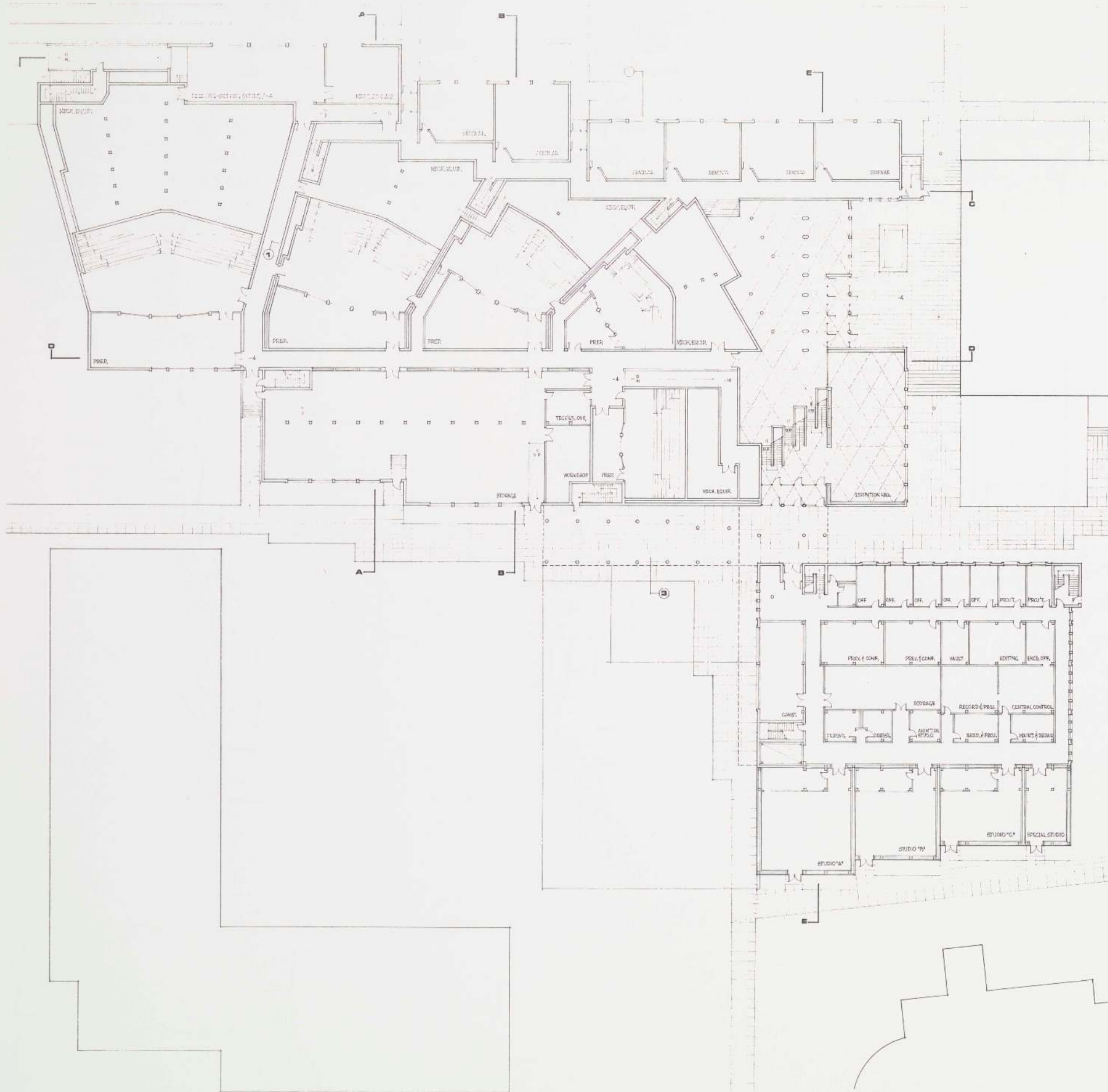

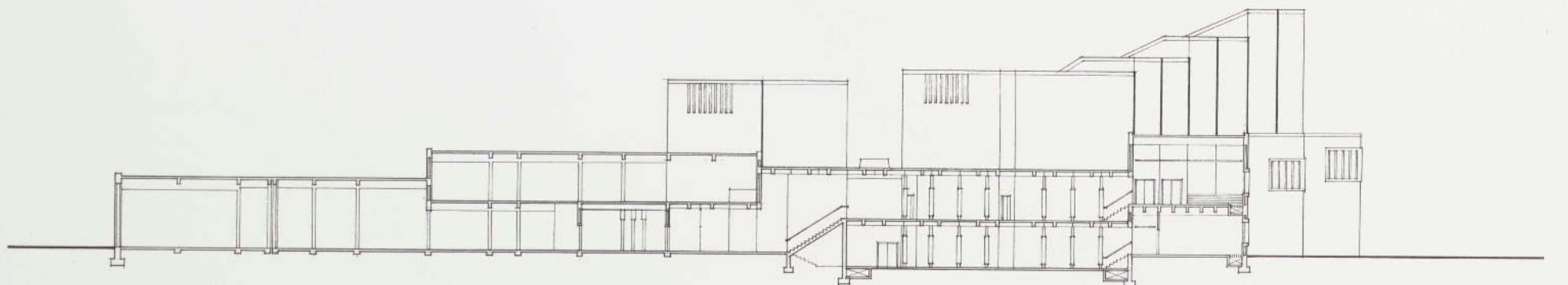
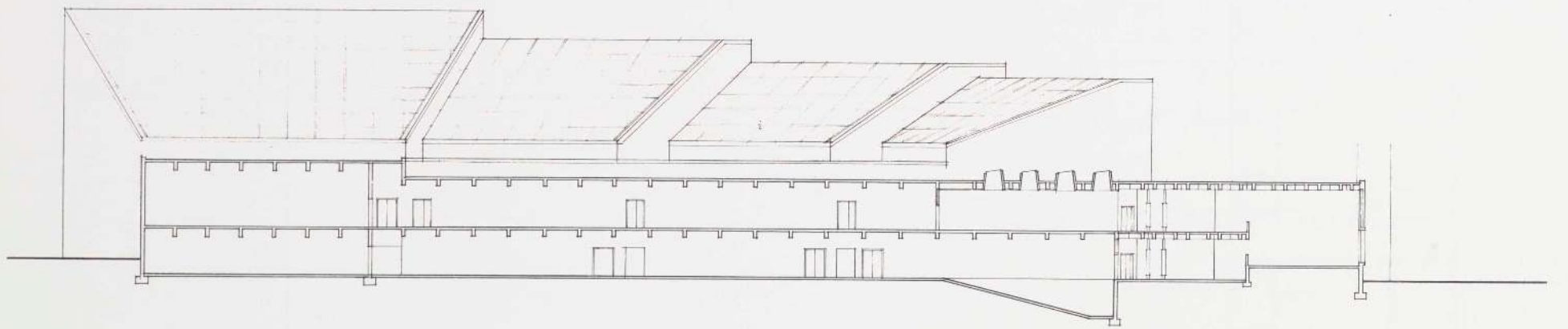
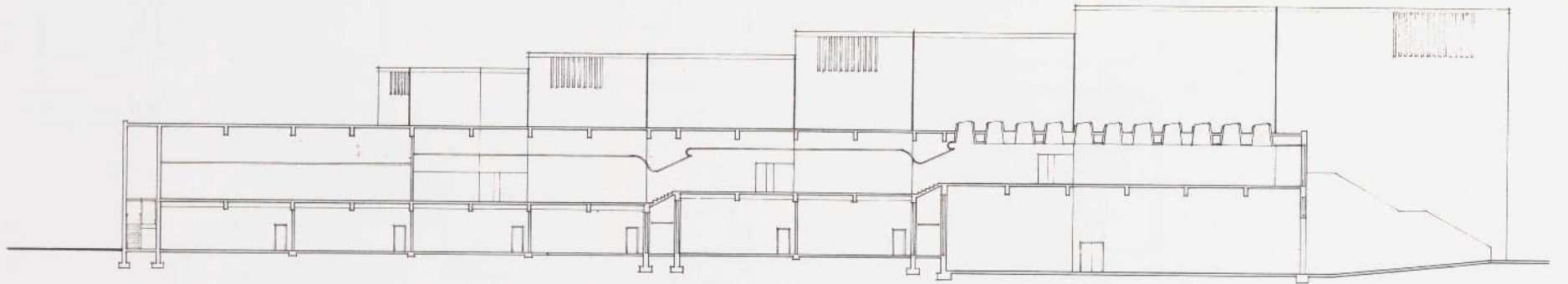
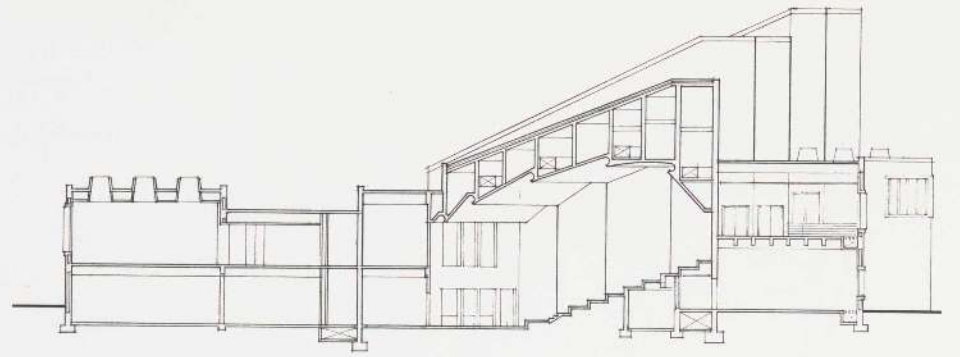
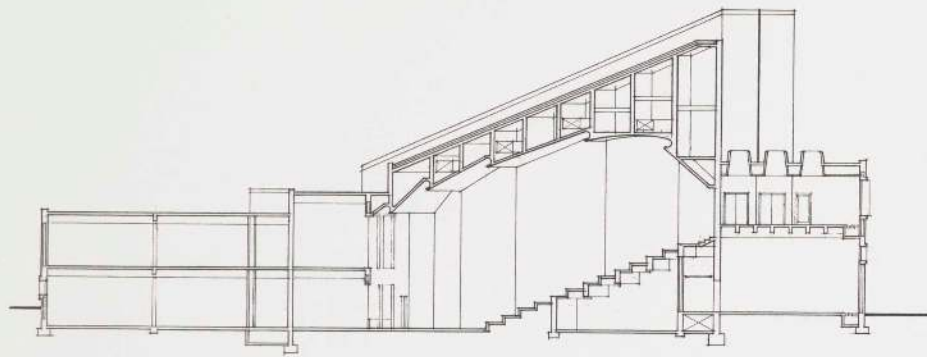

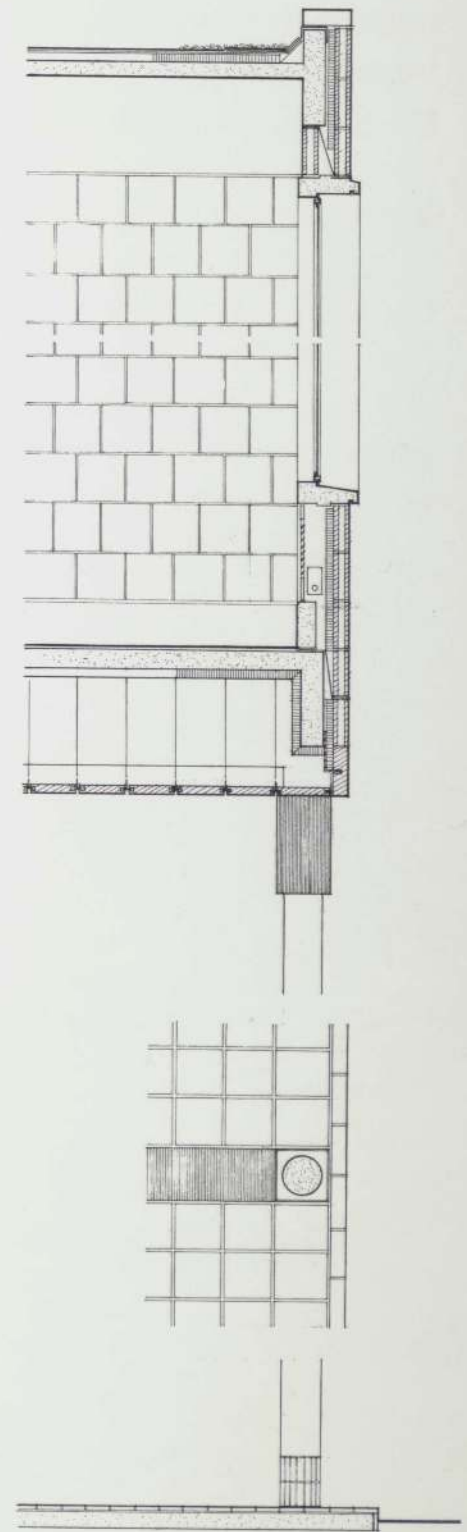
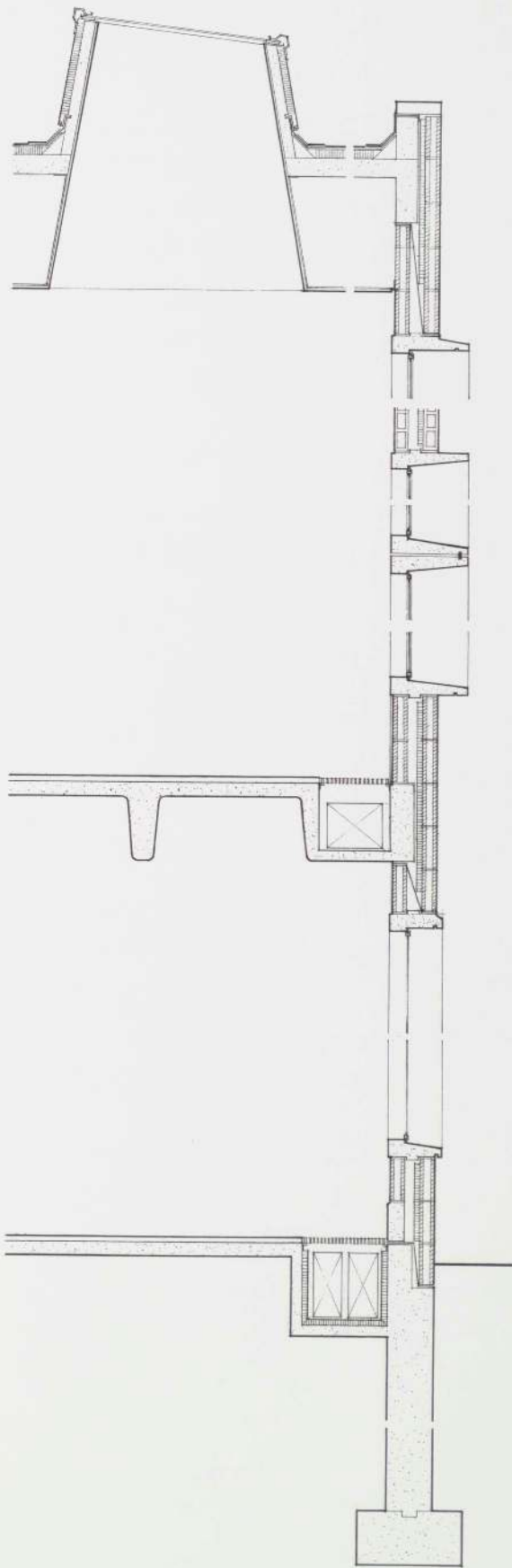
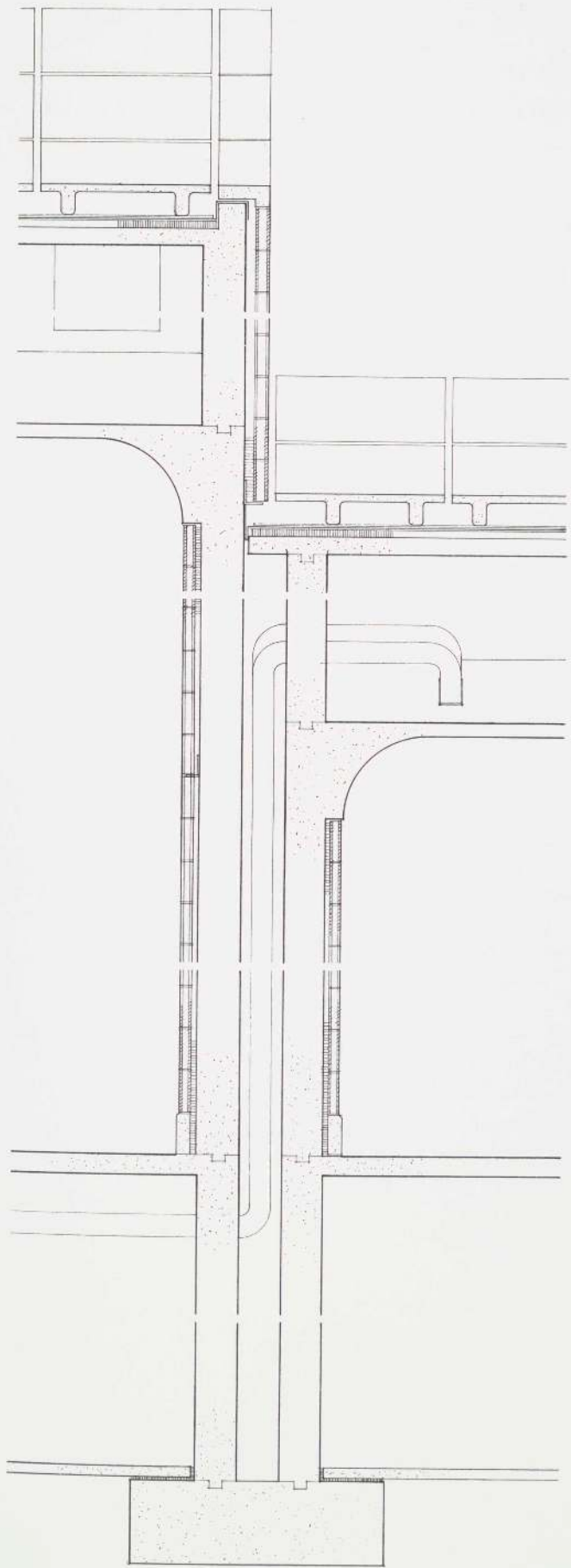

NEW JEWISH MUSEUM/CARMI BEE, RALPH DESIMONE, LAUREL LOVREK, FRED TRAVISANO.

A team of four people in a third year design studio developed this design during one semester. The project had a real client, the director of the Jewish Museum, and the program was developed according to the client's actual requirements. The design process, in addition to program development, consisted of preliminary research; schematic design development; mechanical, acoustical, and structural studies; preliminary and final design presentations; and the partial execution of working drawings. In conjunction with this effort, all of the term's individual courses were coordinated in such a way that each focused on one aspect of the design process. The building concept for the New Jewish Museum can be characterized as being a series of diversely proportioned spaces relating to different types of exhibits and functions, linked together by a spiraling ribbon of circulation. The building is wrapped about the perimeter of the site in such a way as to create a barrier against its two undesirable sides, thereby forming a large open court isolated from external disturbances. The outdoor courtyard, which is entered at various points along the path of circulation, becomes the major orienting element of the building. The building, although seemingly personal in concept, is actually the result of four students interacting on many levels in an attempt to create a rational basis for architectural decision making and consequently a highly unified building design.

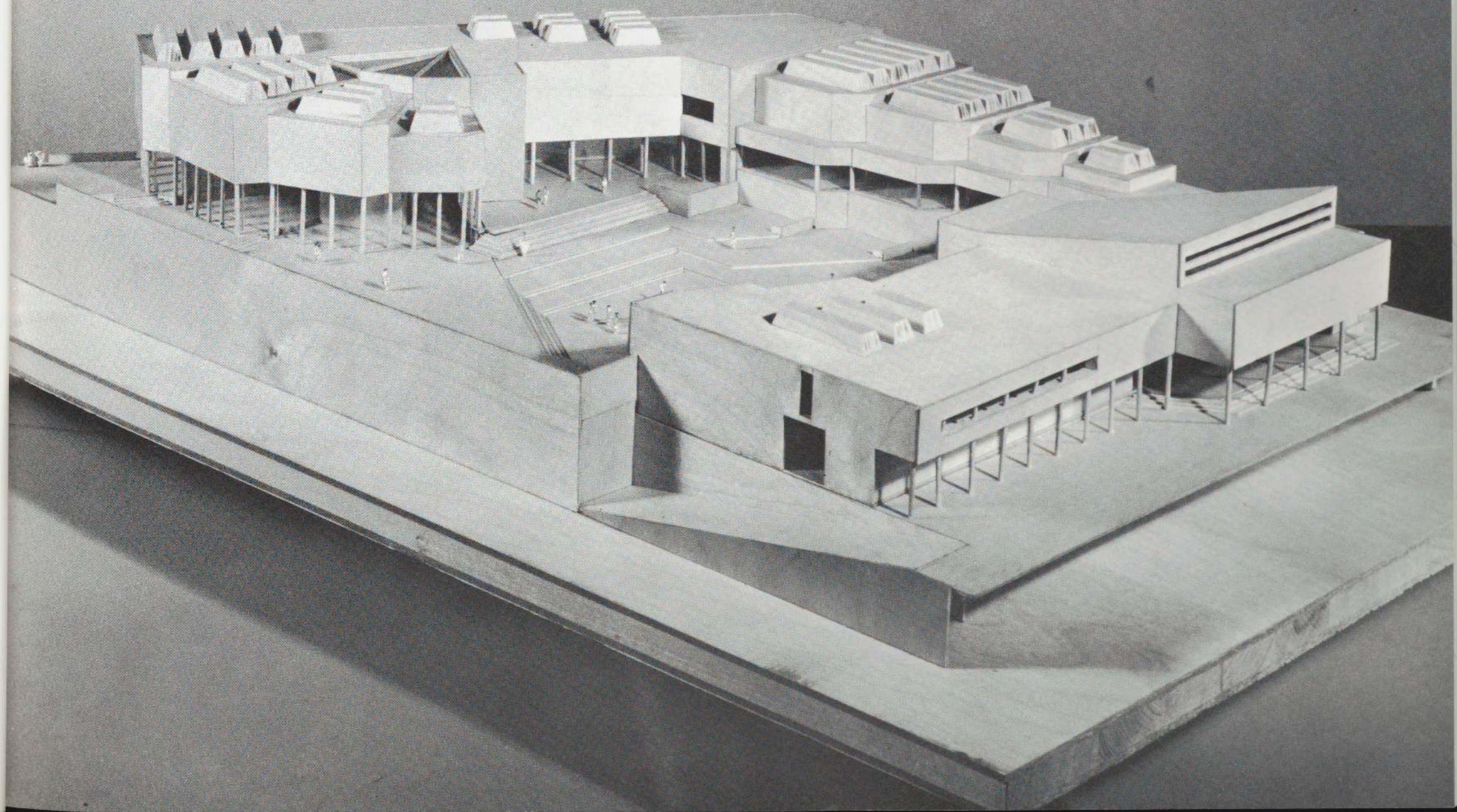

COMMUNITY THEATER/ROGER CANON.

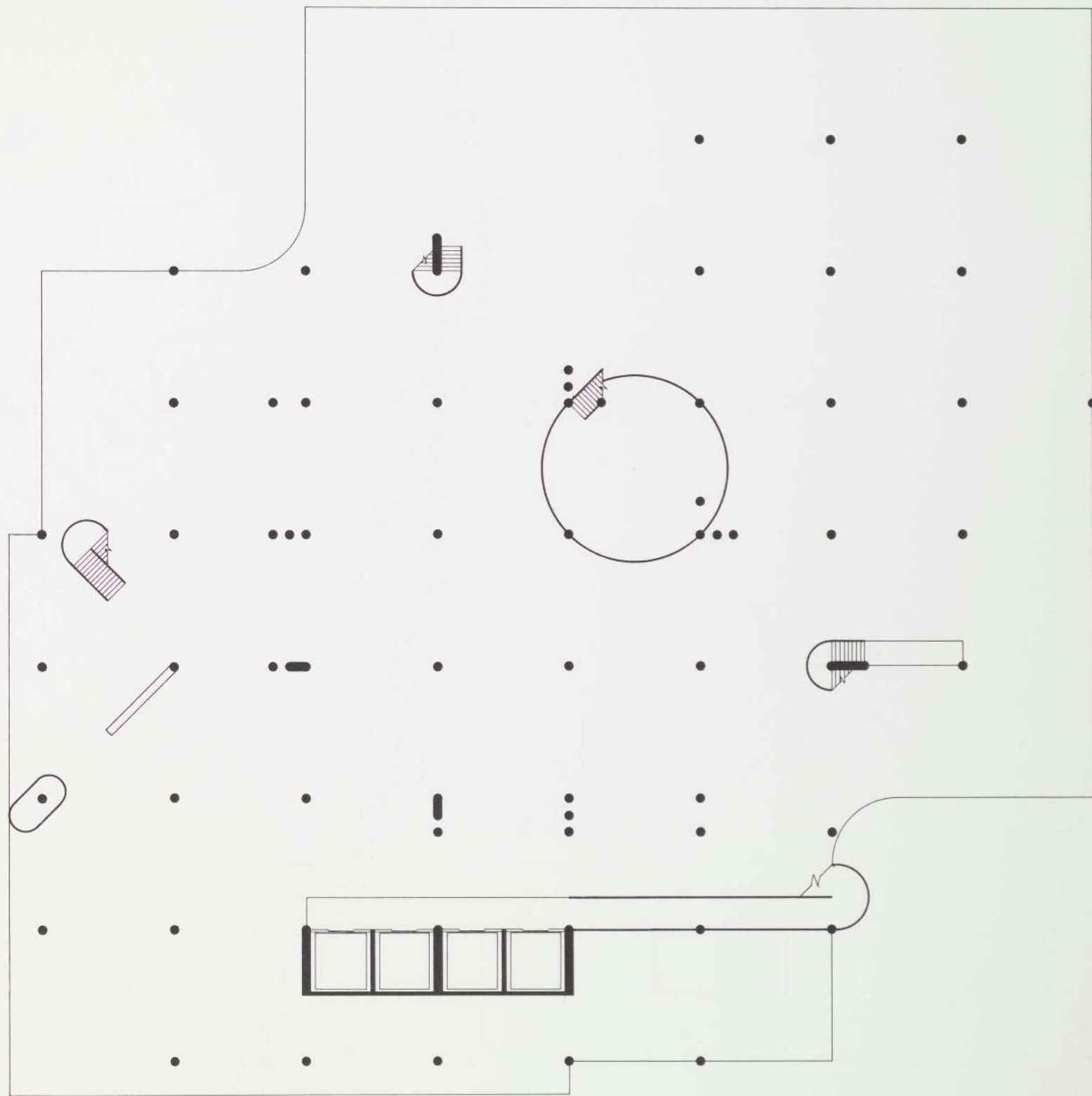

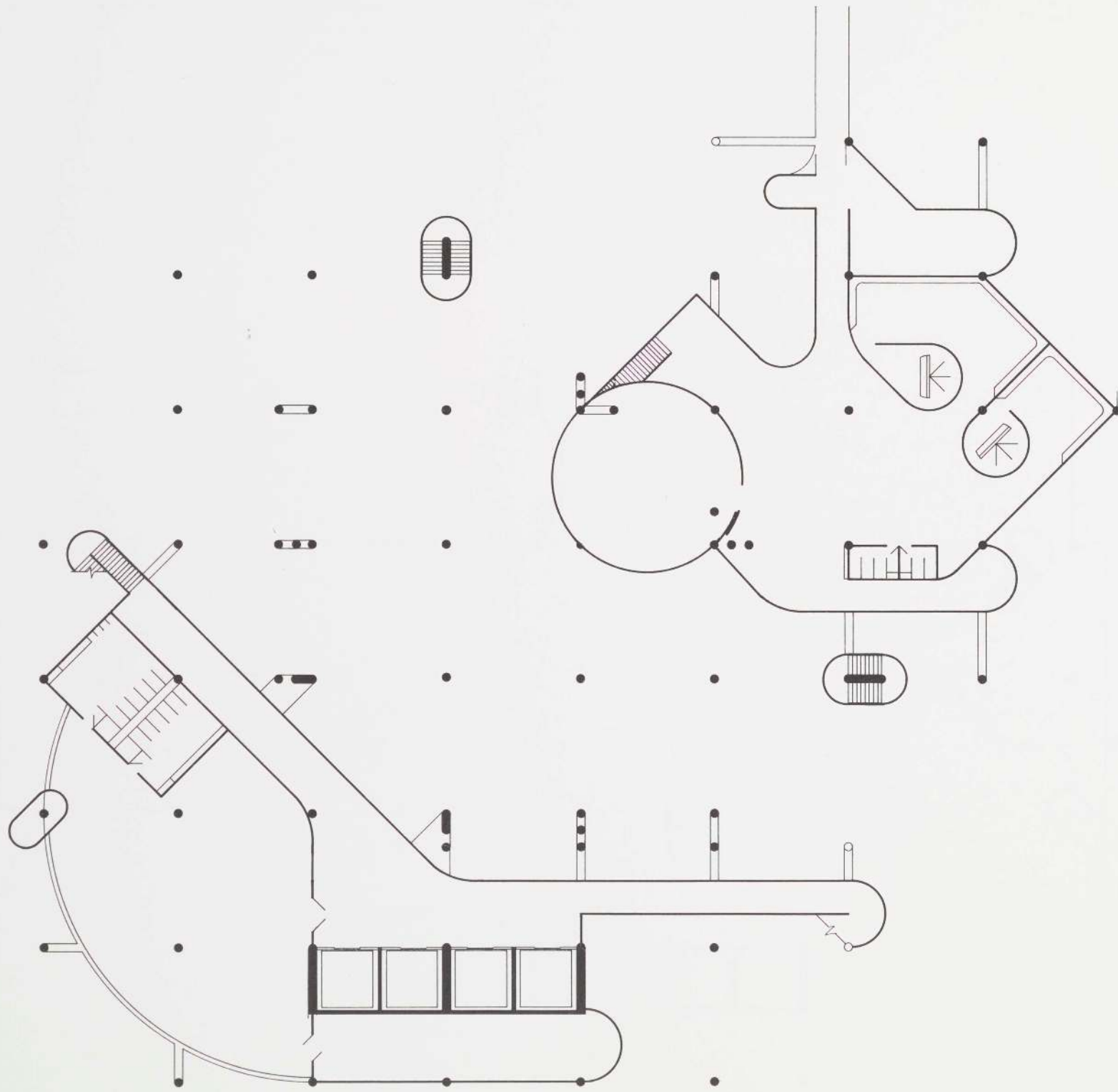

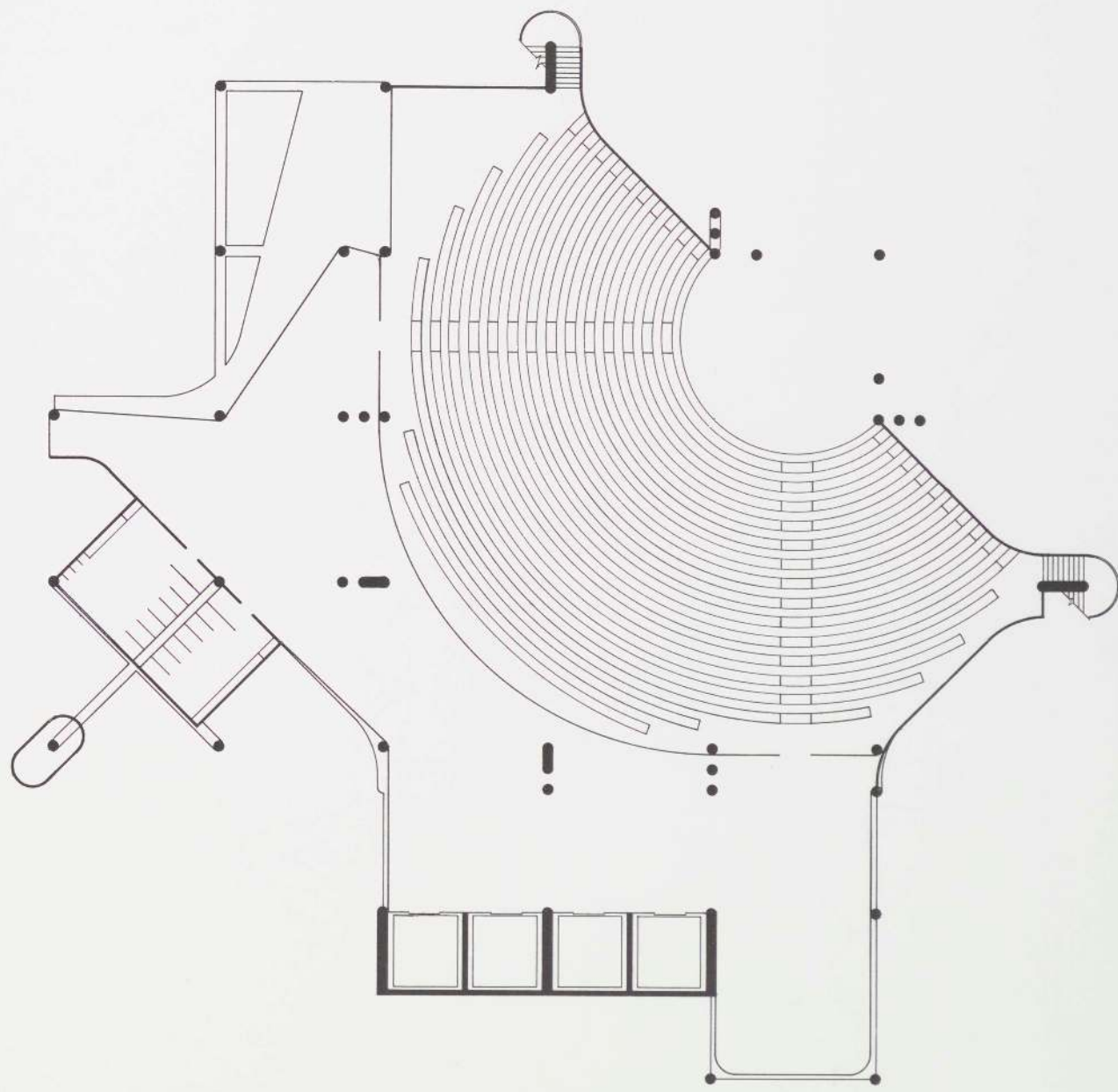

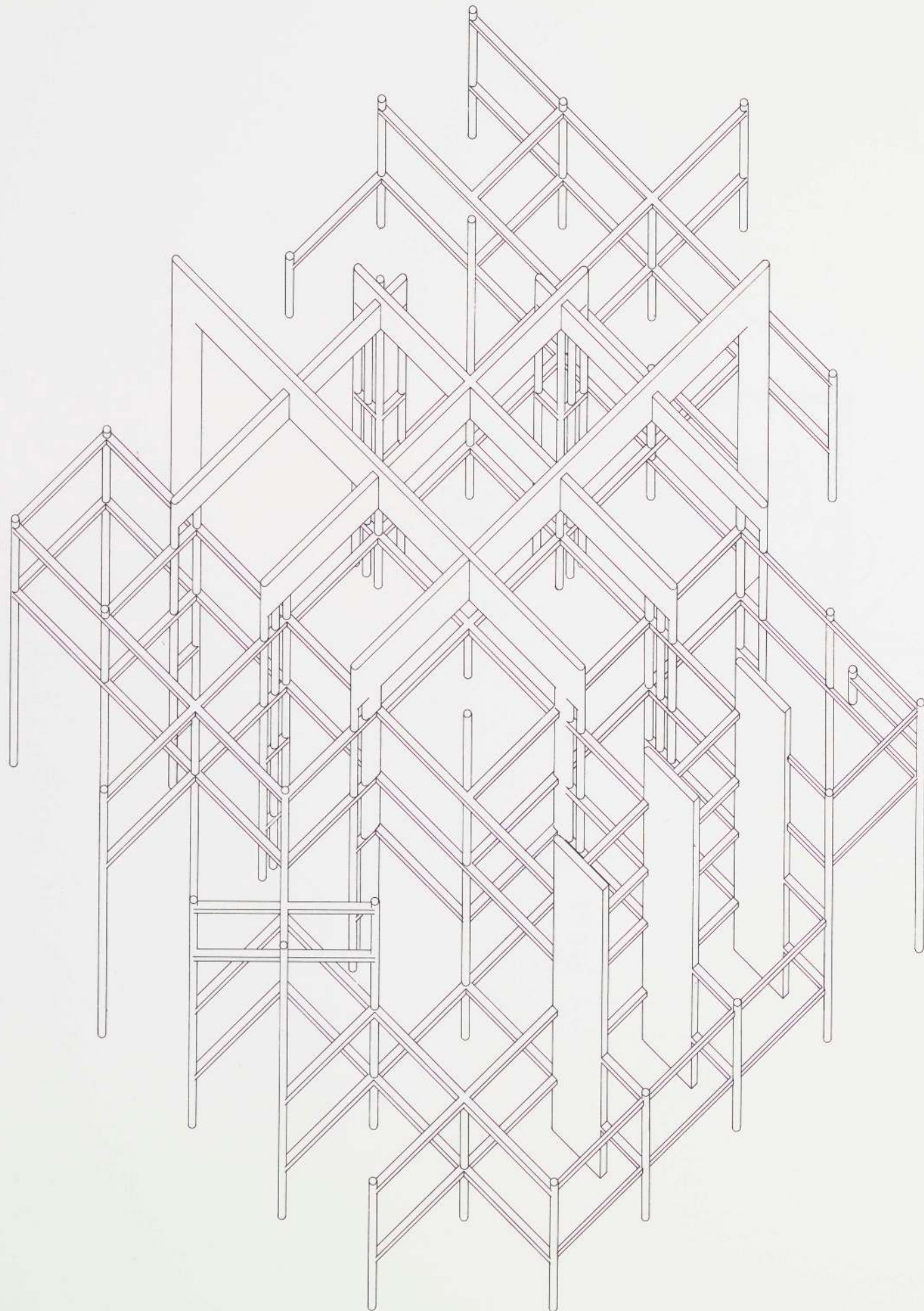

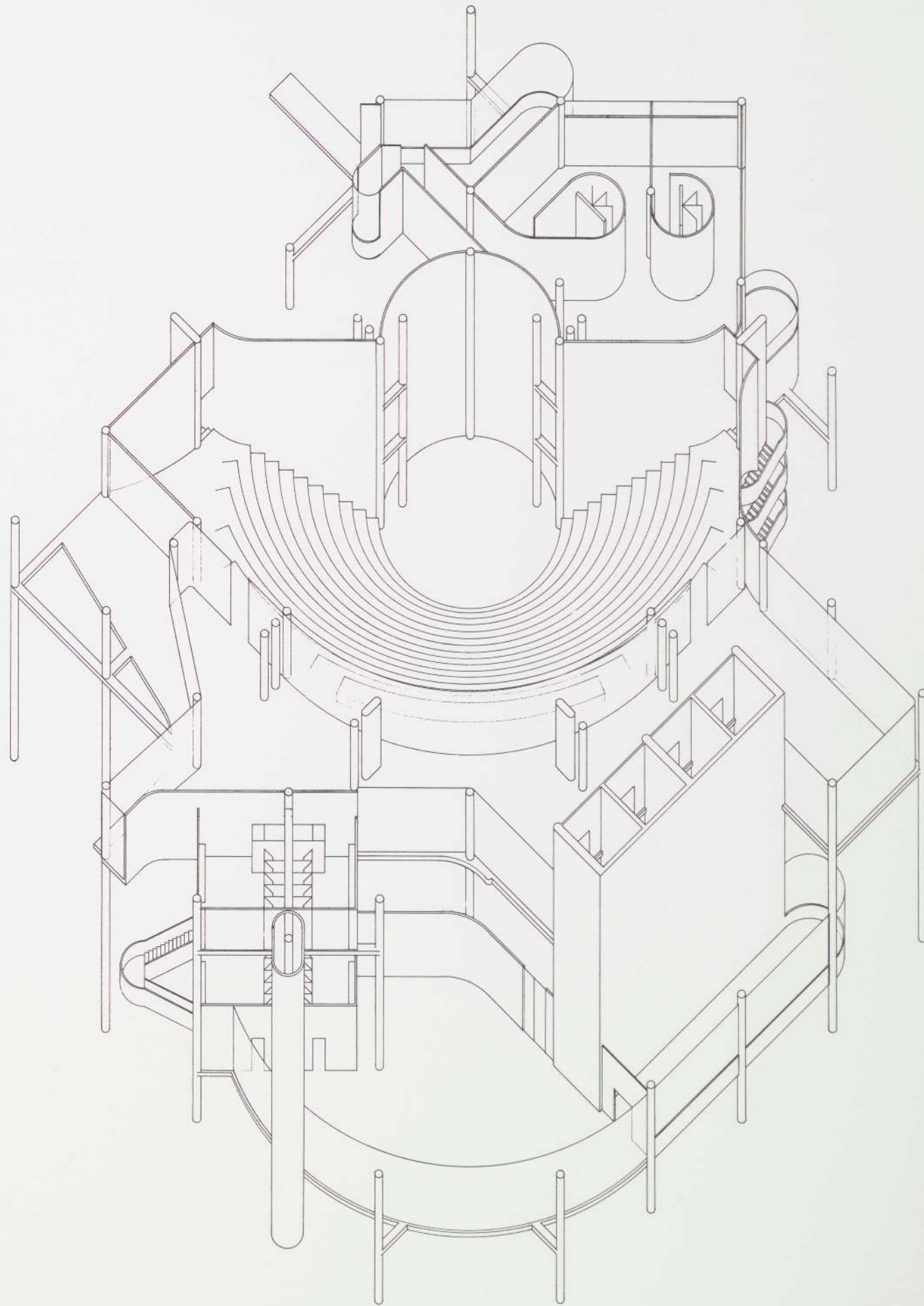



THE CUBE PROBLEM. A Cube problem is not unique to a particular architectural school; it is somewhat universal; its staying power appears to profess that it will still be used for some time in the future as a didactic problem. The interest lies in how it is viewed. It is typical that the architect is given a program from which an object emerges; it does seem possible that perhaps the opposite could occur. That is, given an object, perhaps a program could emerge. This is one of the premises stated upon presentation of the Cube Problem. Usually, but not always, the problem is stated as, "Given: A 30 x 30 foot cube—invent a program." This problem produces a prolific amount of solutions; for some reason, the object usually produces the program for a house. At first this did seem somewhat disconcerting; yet upon reflection the 'Home of Man' still remains a vital force to the propagation of architecture and ideas.

John Hejduk

THESIS/KENNETH SCHIANO. "They look upon all objects, in fact, whether a static bottle or a racing horse, as embodying two kinds of motion: that which tends to move in on itself, suggesting in its centripetal force the internal mass of an object; and that which moves outward into space mingling its rhythms with those of other objects and eventually merging with space itself."

'Futurism', Joshua Taylor

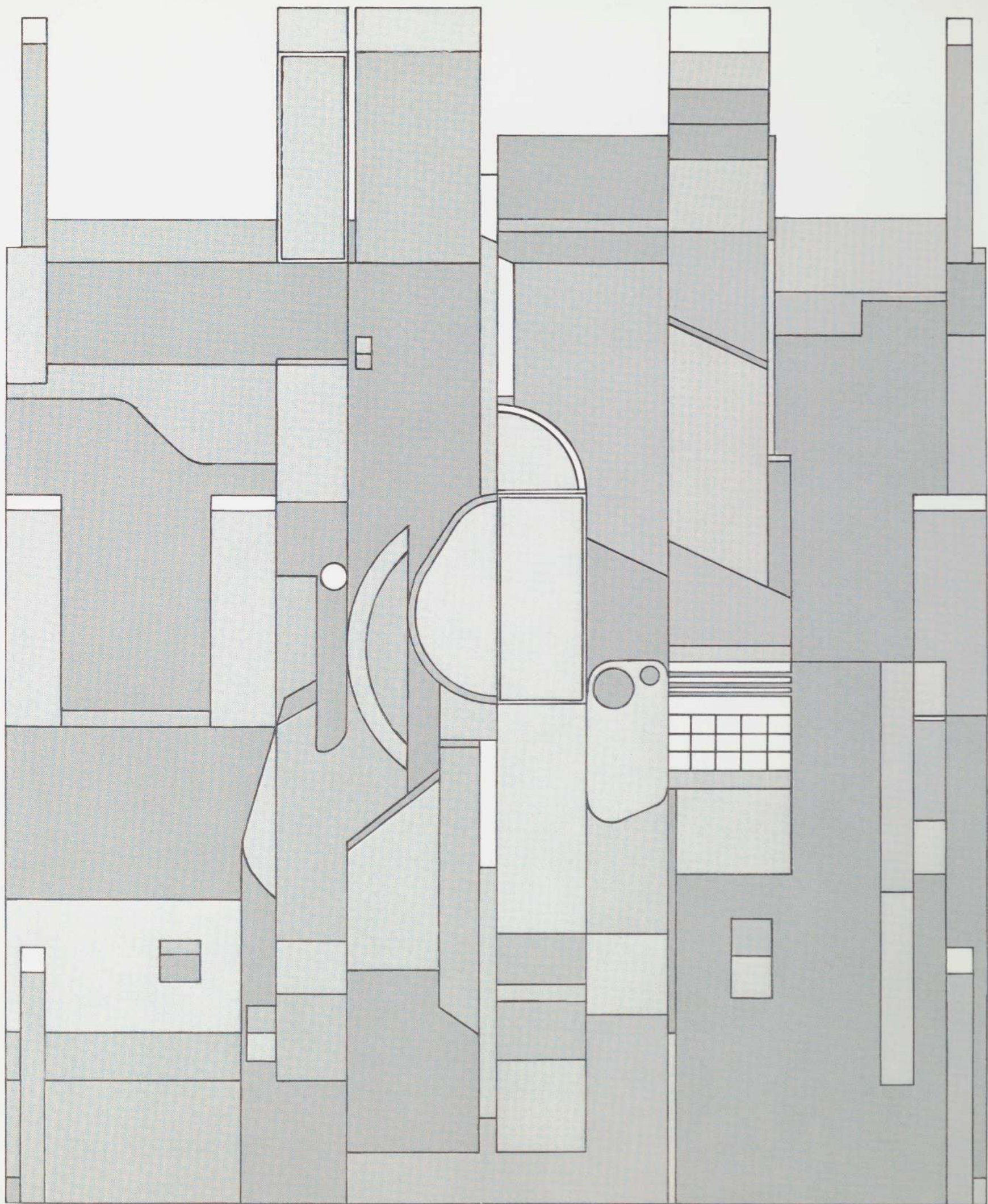

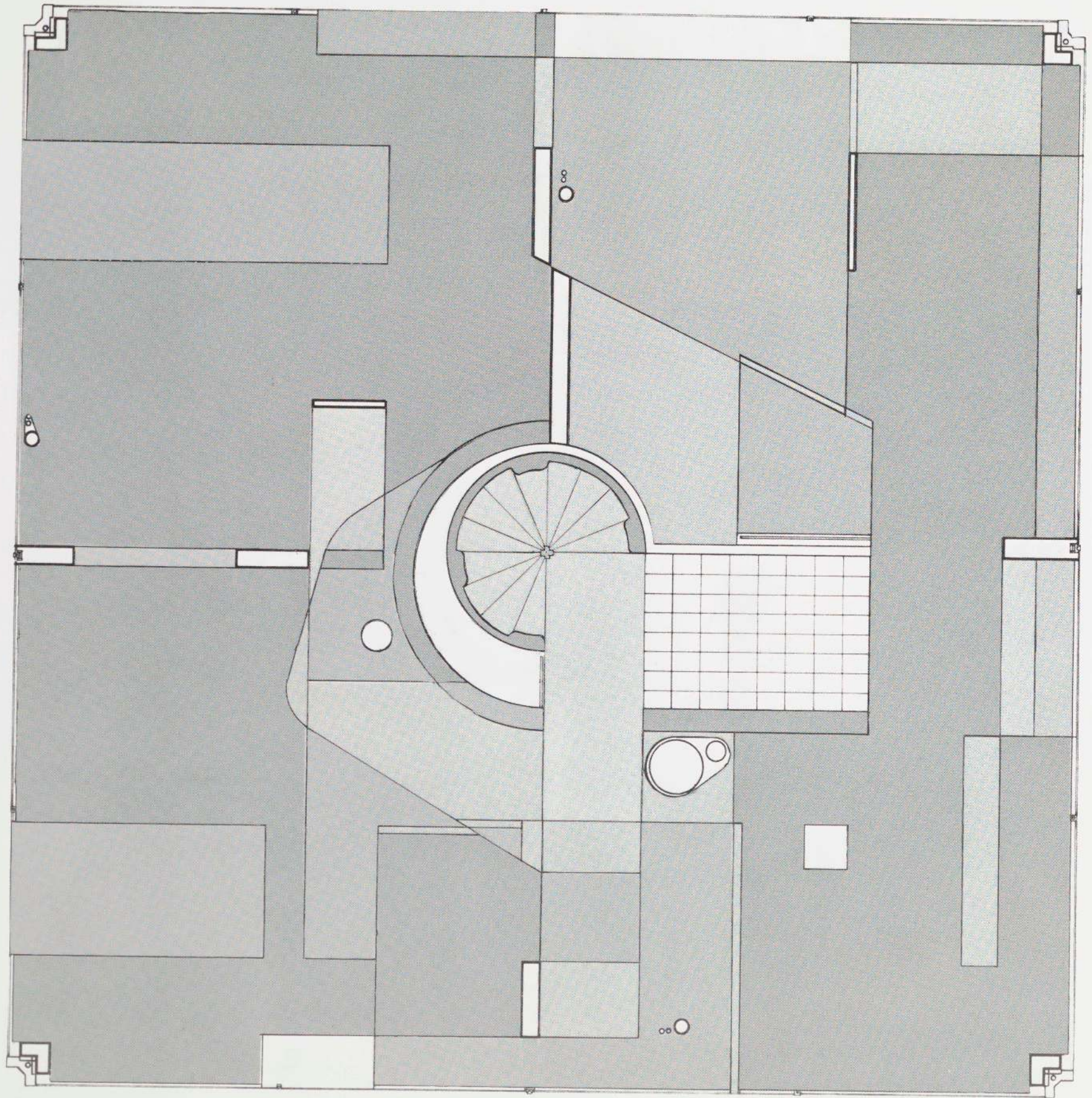

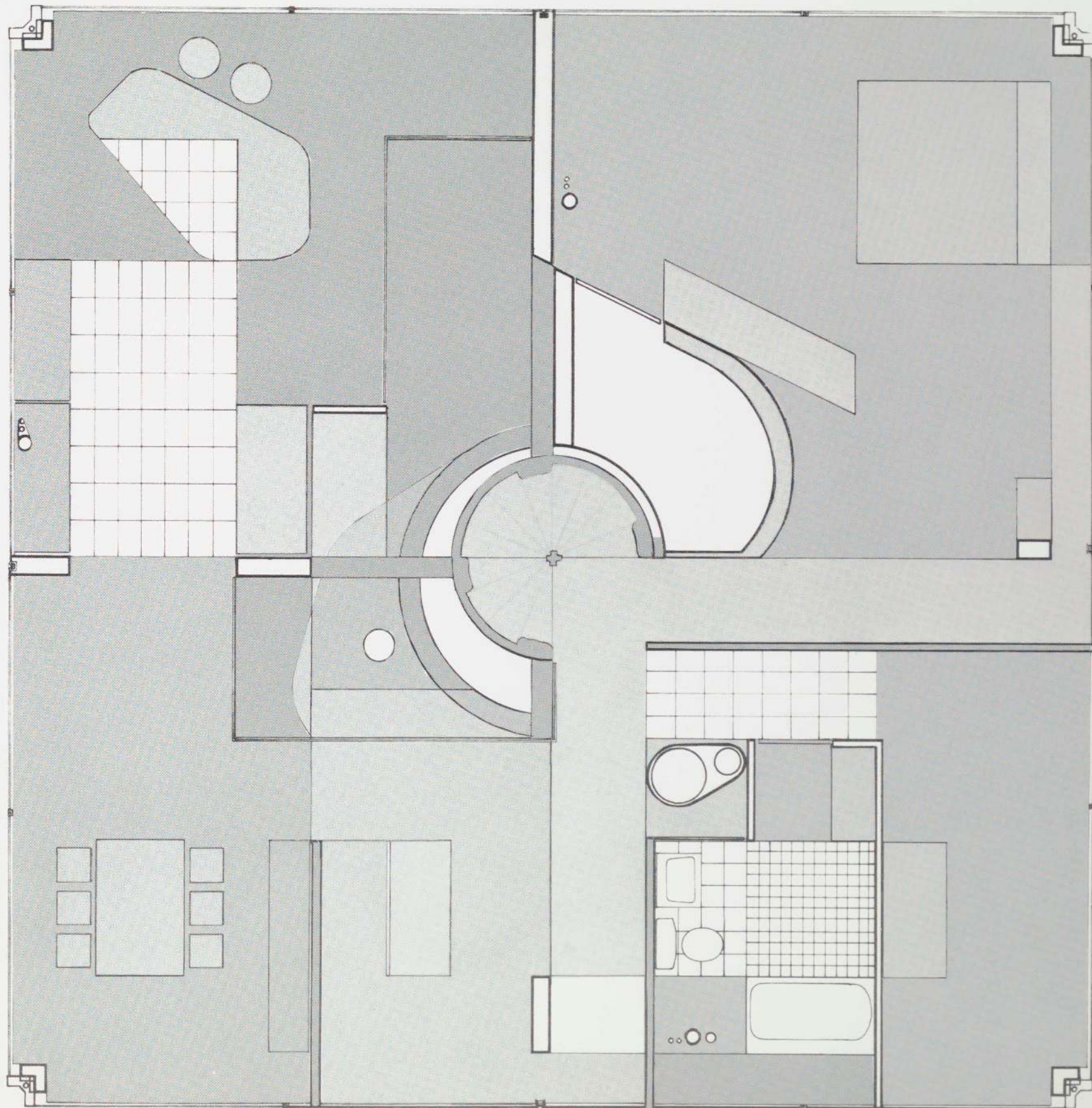

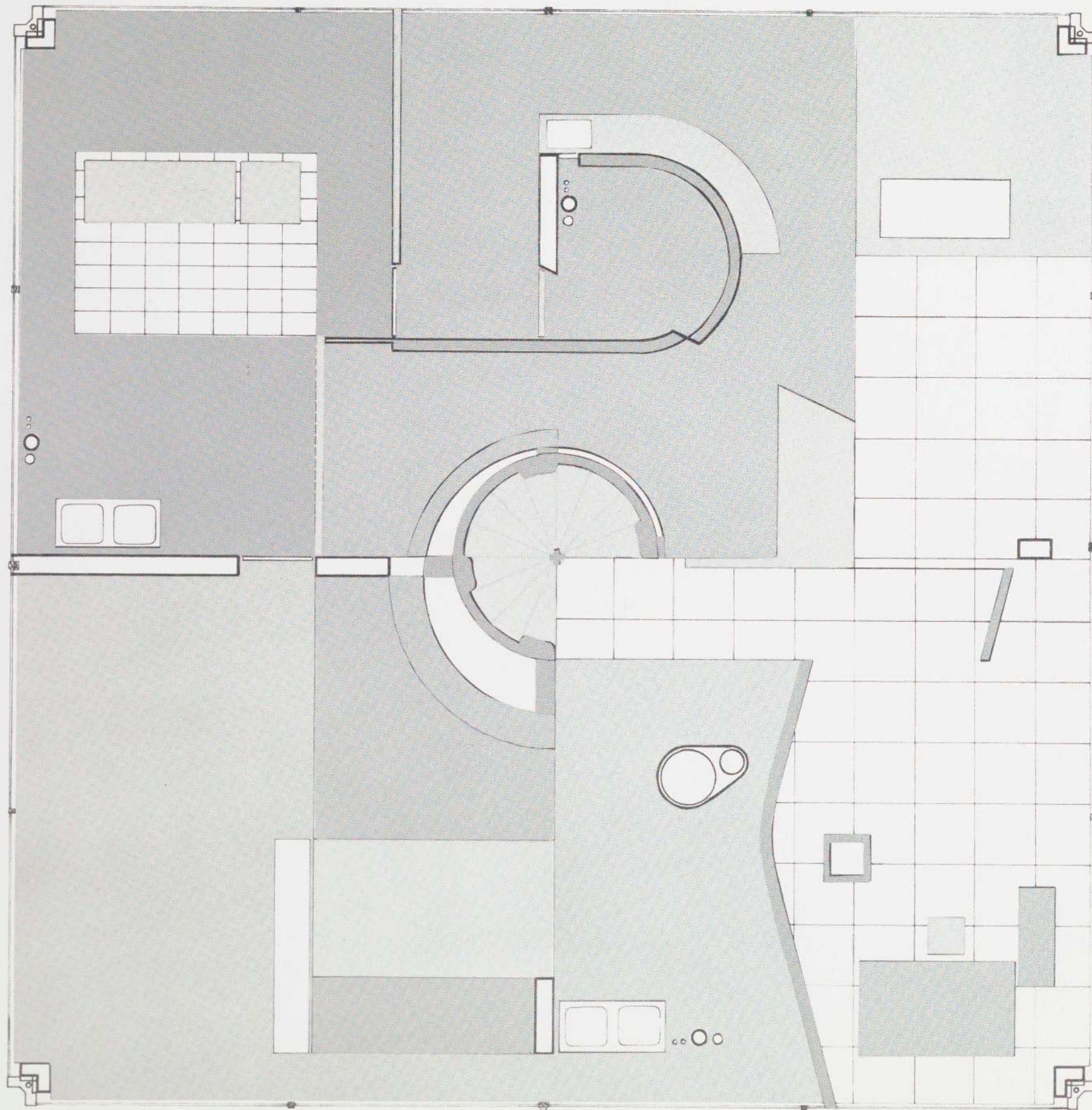

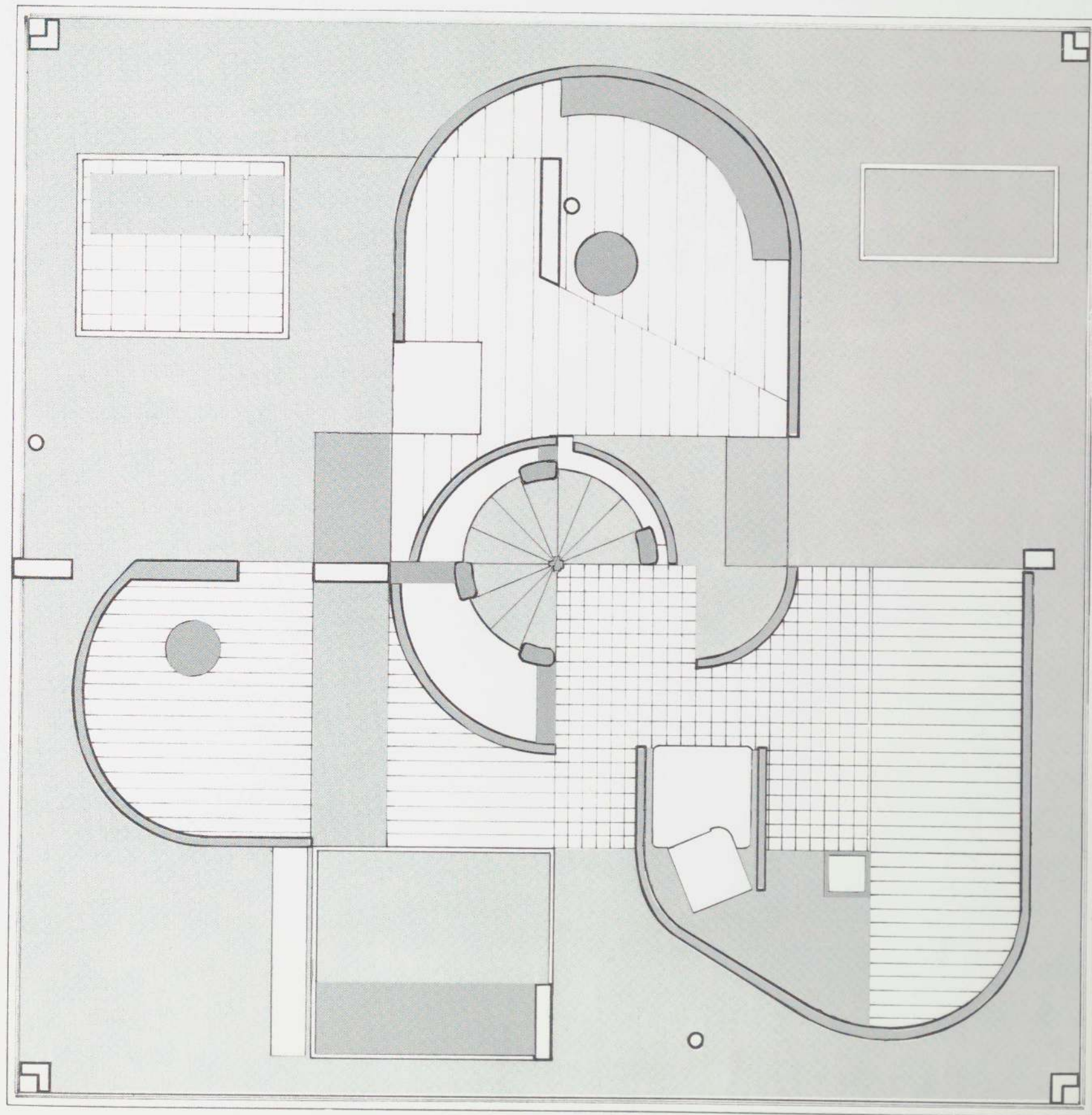

AN EXPERIMENT IN ARCHITECTURE/THEODORE CERARDI. For this composition I have limited my study to the Cube. The Cube constitutes a small house containing the basic amenities for living. The Cube has numerous properties. My studies specifically concern the following: six planes, eight points, twelve lines, centroidal or pointal force resolution, and the contrapuntal which connotes the continuum of force in every direction. The synopsis of these properties constitutes *point*. In the Cube I chose to use this pointal phenomenon as the primary design thesis. The results are both internally oriented within the cube-space and contrapuntal to the resolution. This creates a cerebrally non-existent space structure that transcends its cube-like boundaries in every direction, still remaining as object-architecture. The elements of the composition are forms or objects which may be considered found and/or contrived. They are metaphorical. The composition is new. The resulting house is an experiment in logic. Its objective subjectivisms, or architecture, become apparent when one says stop. The Cube, as a presented solution, is a piece of time which has a tenuous balance in the flux of compositional possibilities.

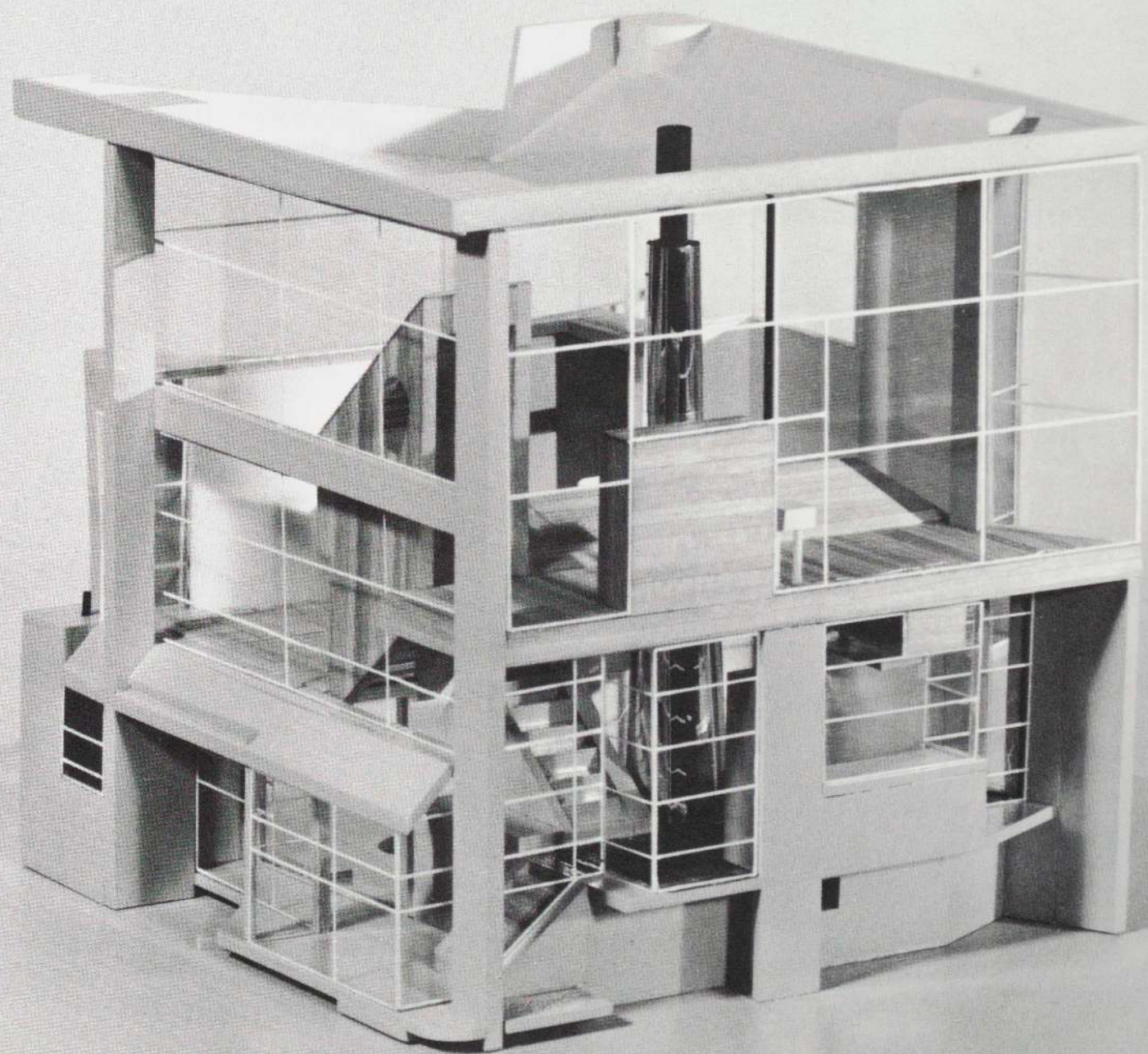

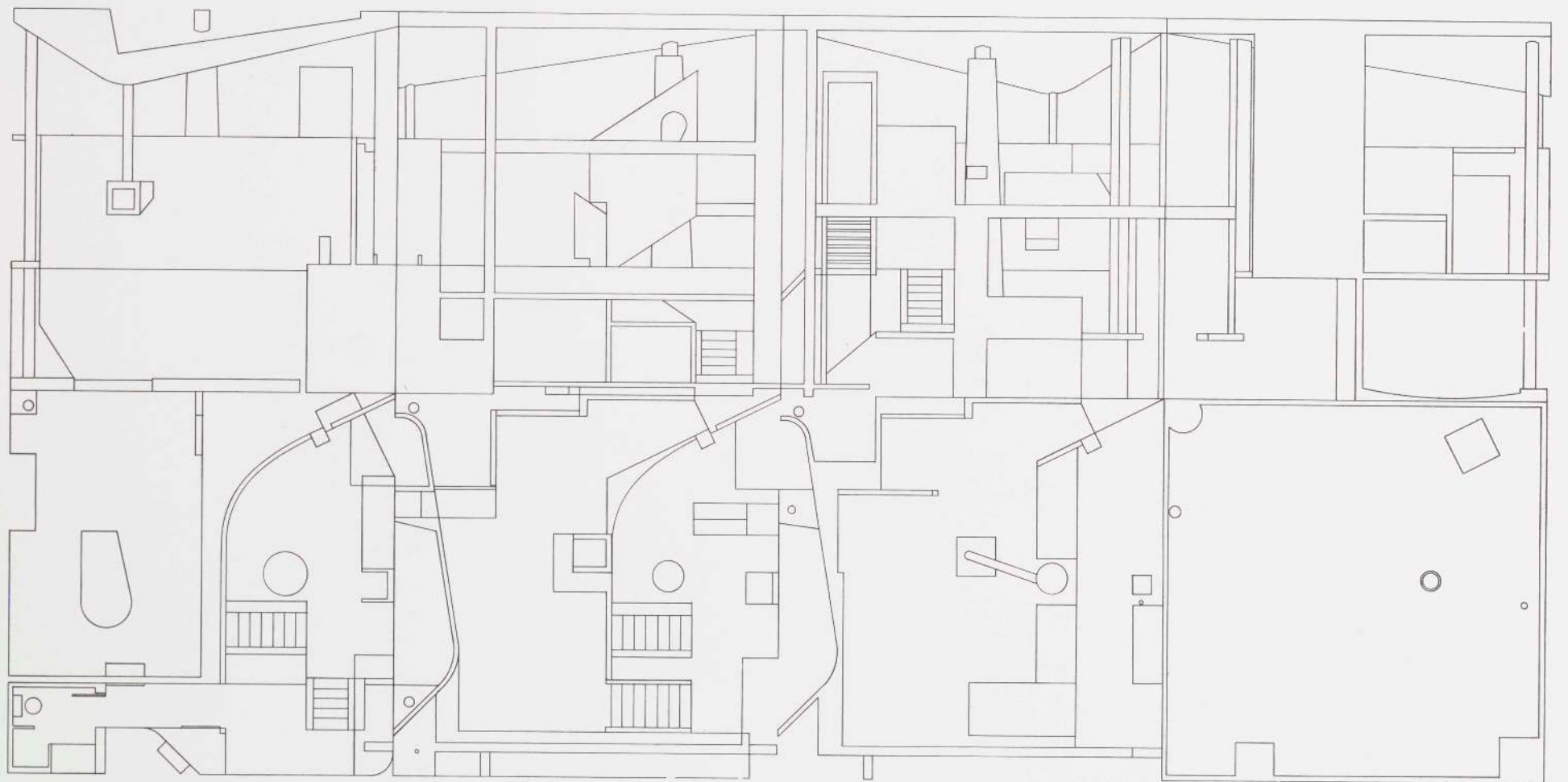

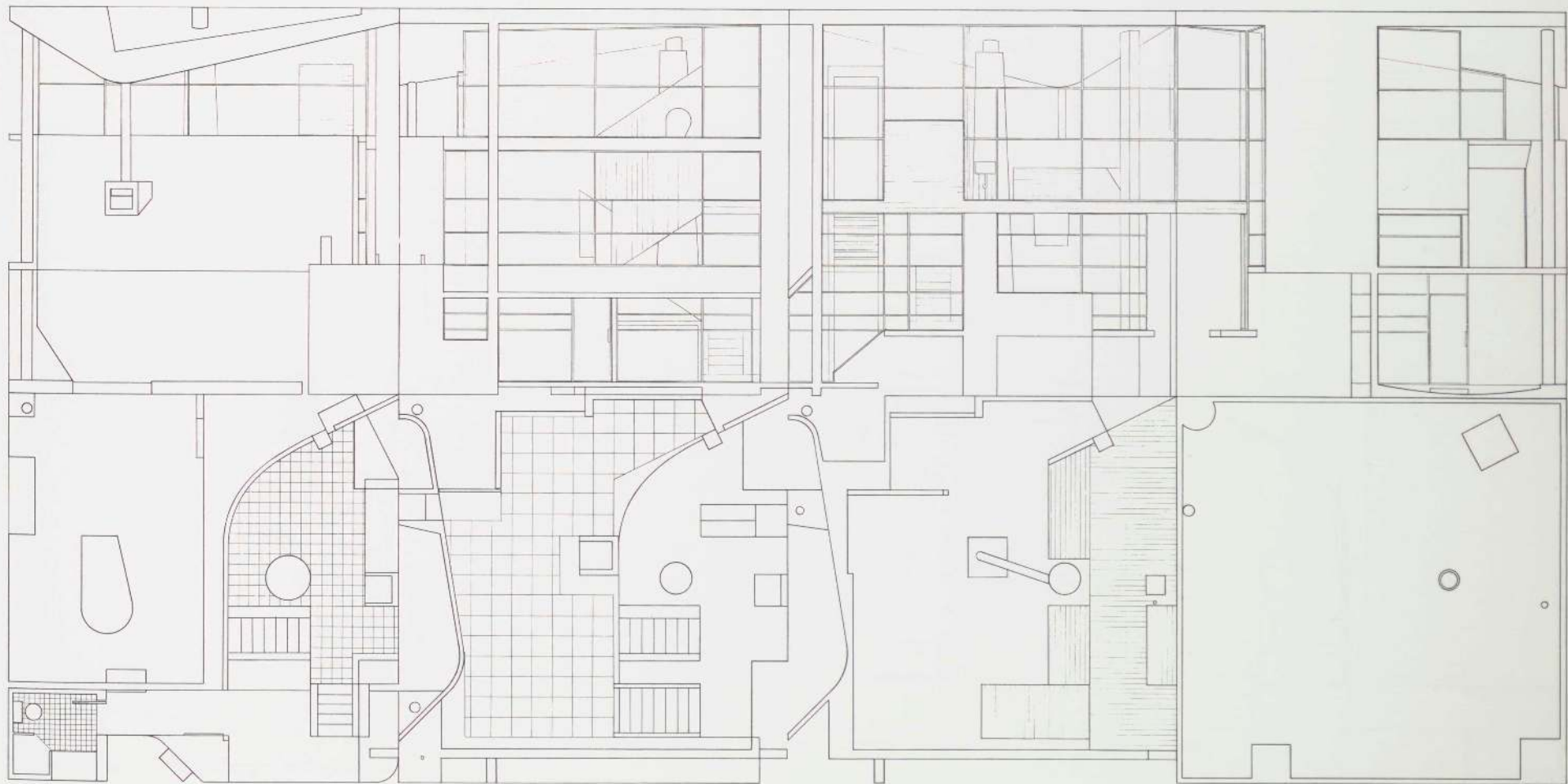

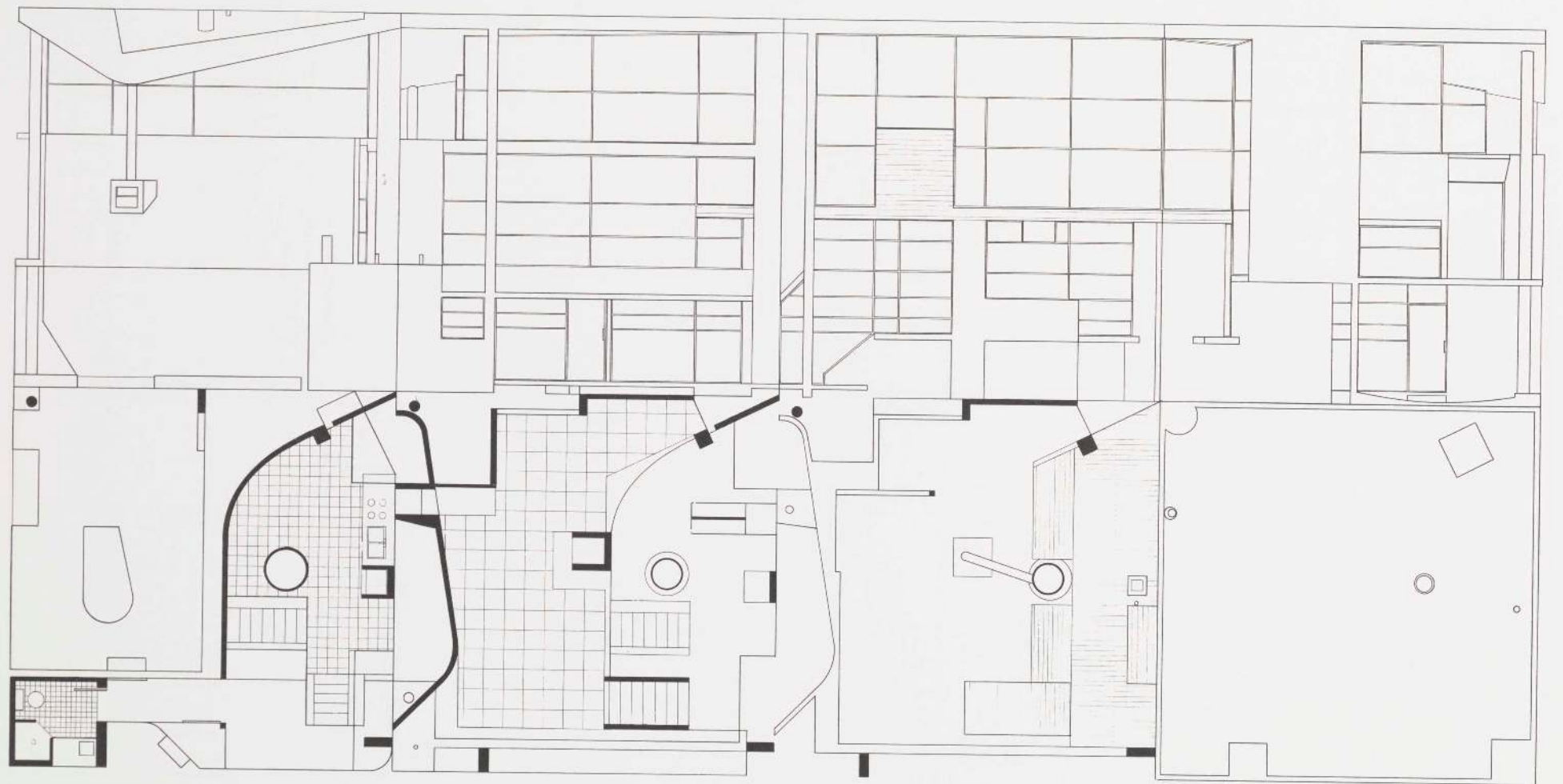

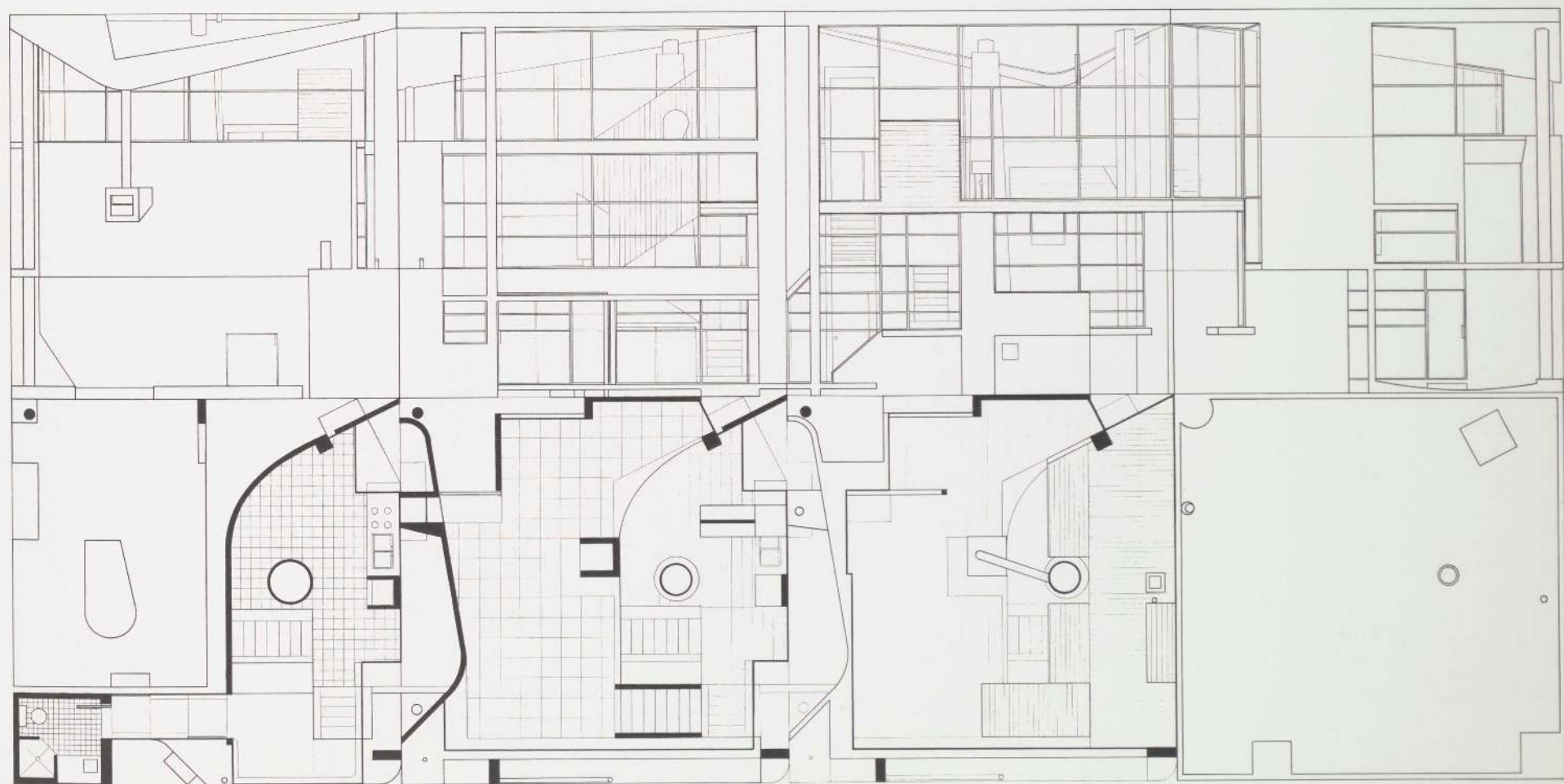

THESIS/LAWRENCE GOLDBERG. The aim of this project was to manipulate the inherent geometric qualities of the cube and its diagonals into a rational, perceivable whole. By superimposing varying conceptions of spatial completion and incompleteness (through the means of solid vs. void; transparent vs. opaque; color; and texture) upon the geometric properties of the cube, the emphasis and de-emphasis of any particular property was accomplished while maintaining an awareness of the whole. The pragmatic aspects of a building are integrated into the architectonic elements of the design, thereby bringing the project to a certain level of reality. Perhaps the design's development and present state can best be described as an 'Op' block puzzle. 'Op' because of its optical and spatial ambiguities, and a block puzzle because it has key pieces which unite it, one manner of assembly, and each piece is an entity in itself by virtue of the whole.

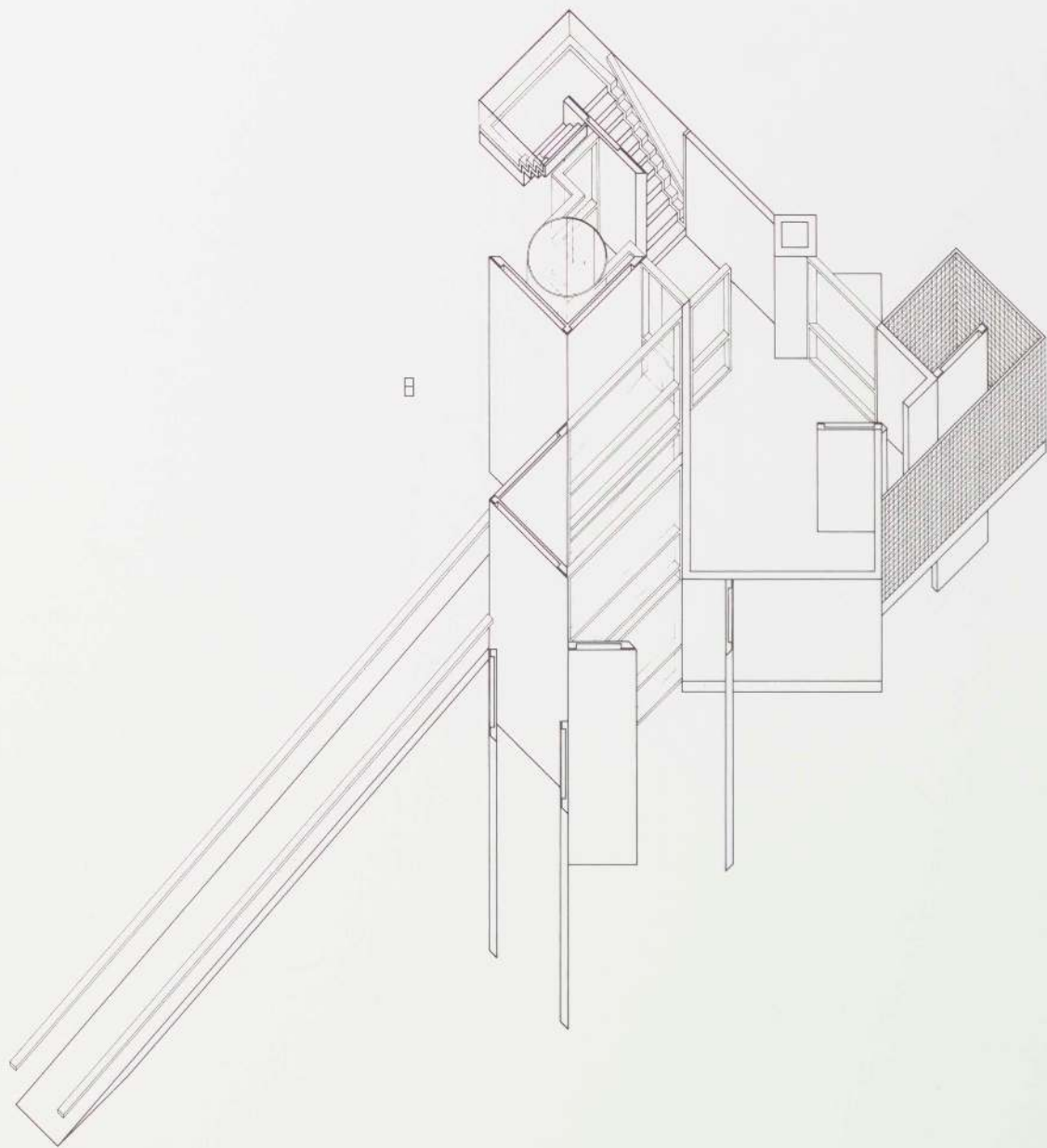

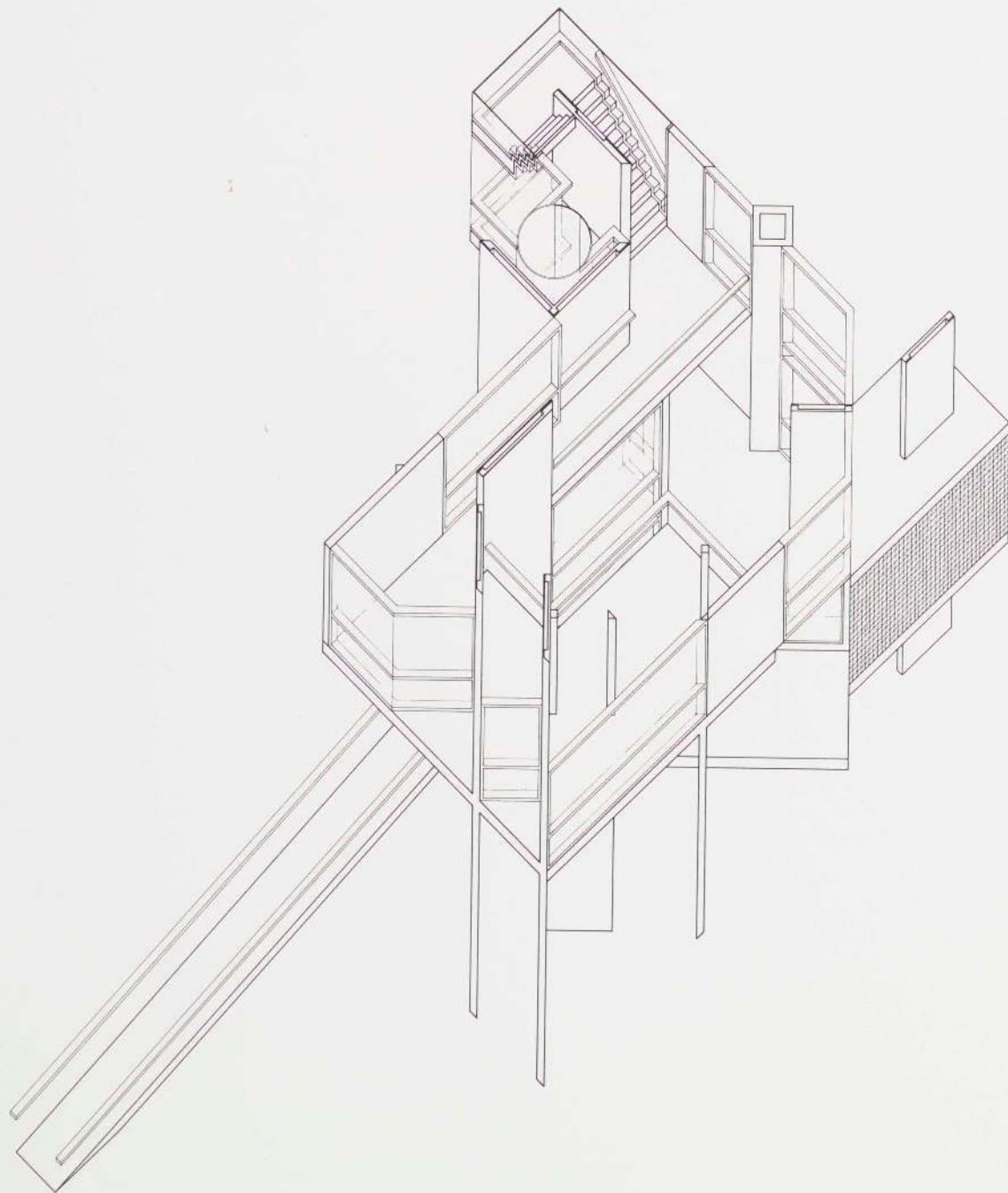

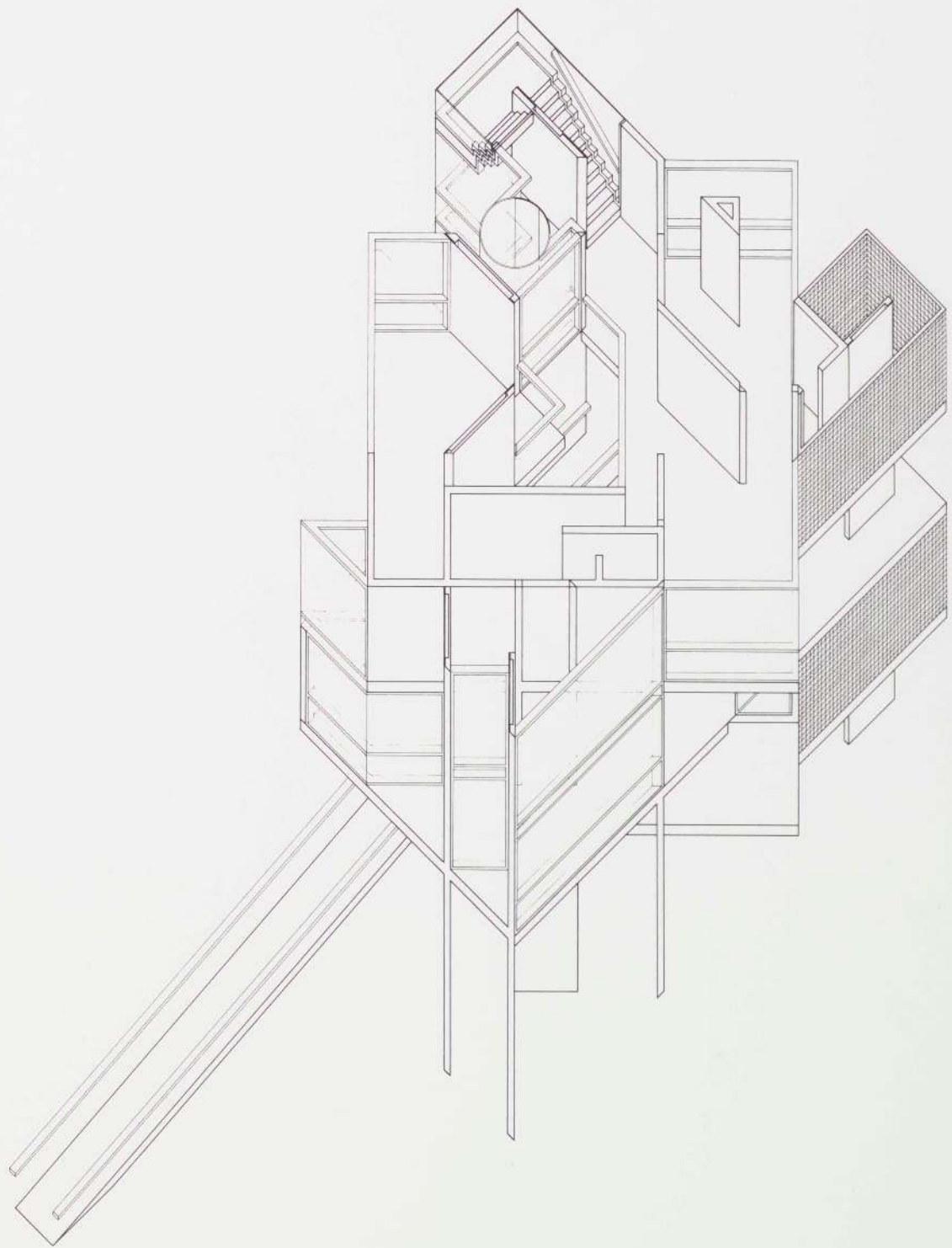

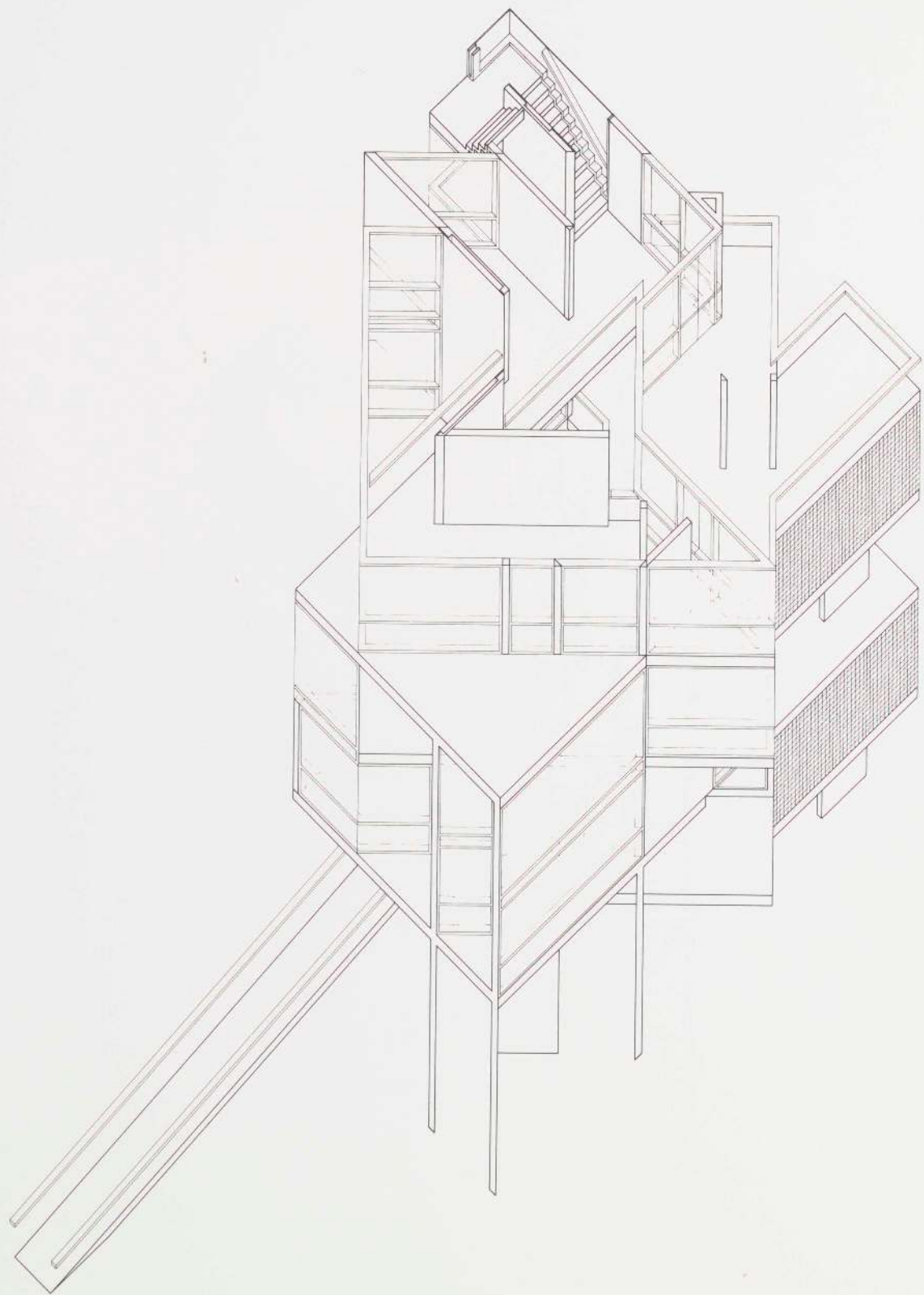

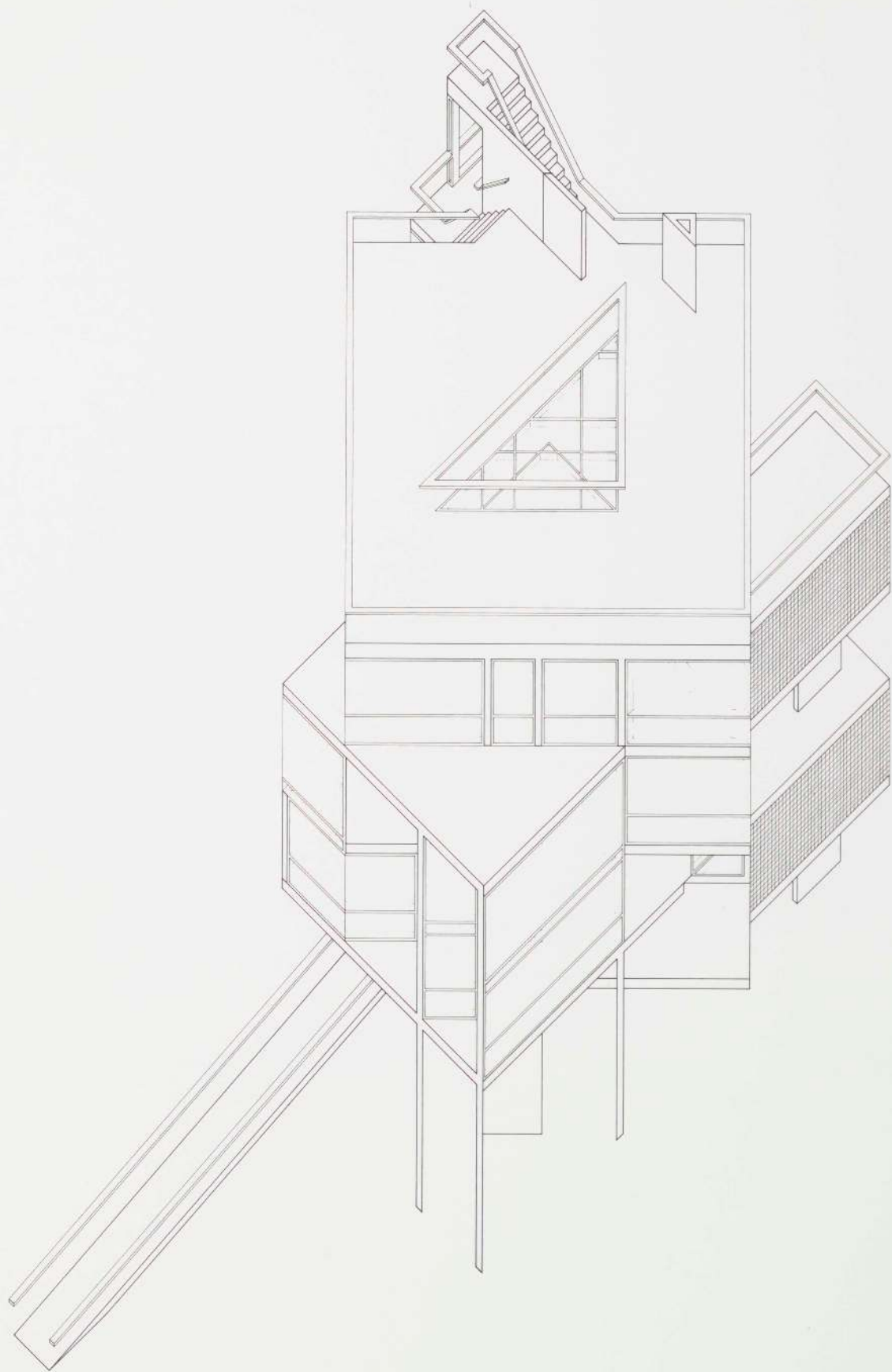

PREFABRICATED HOUSE/STEVEN M. ESKIND.

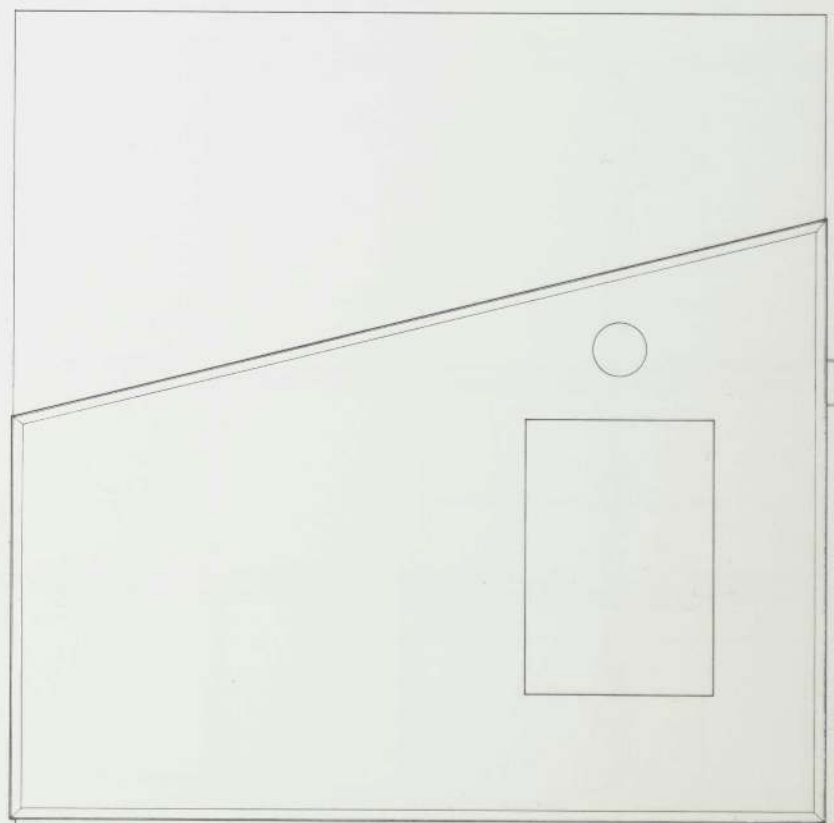
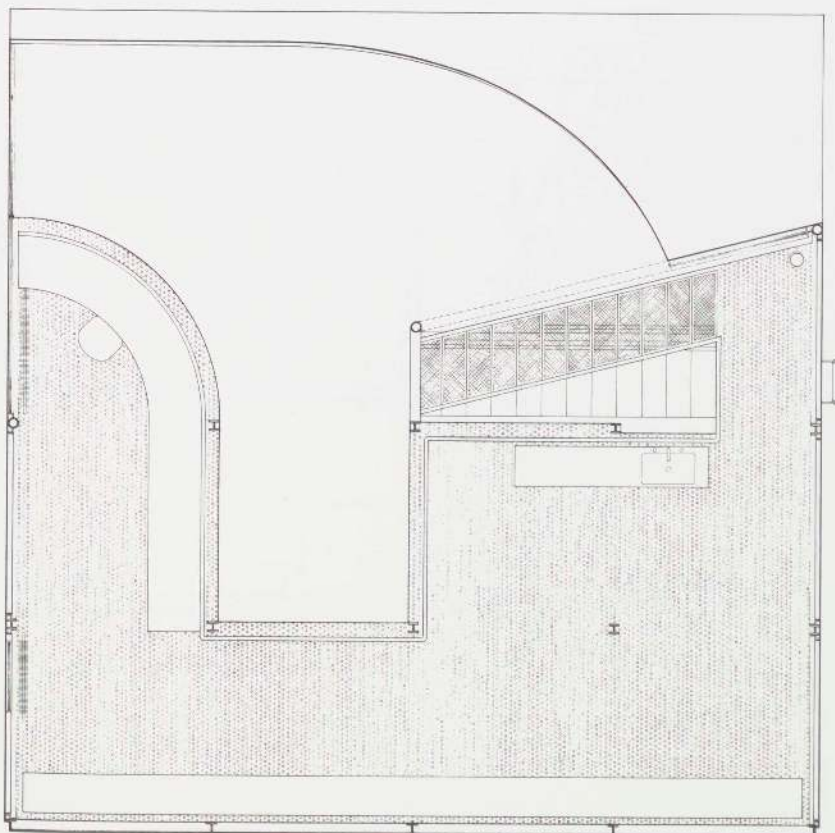
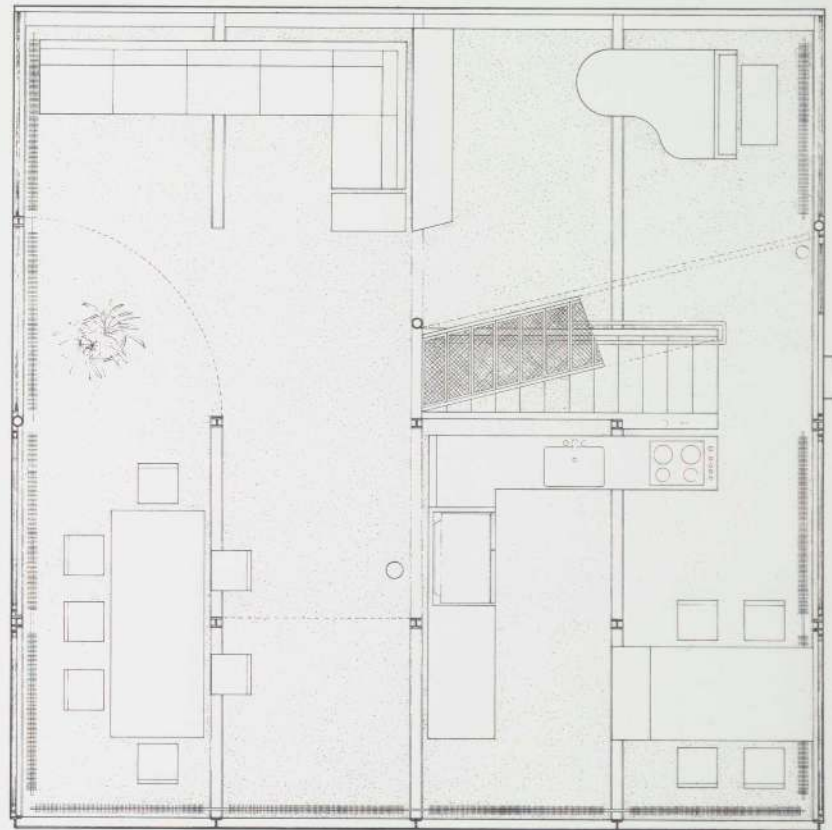
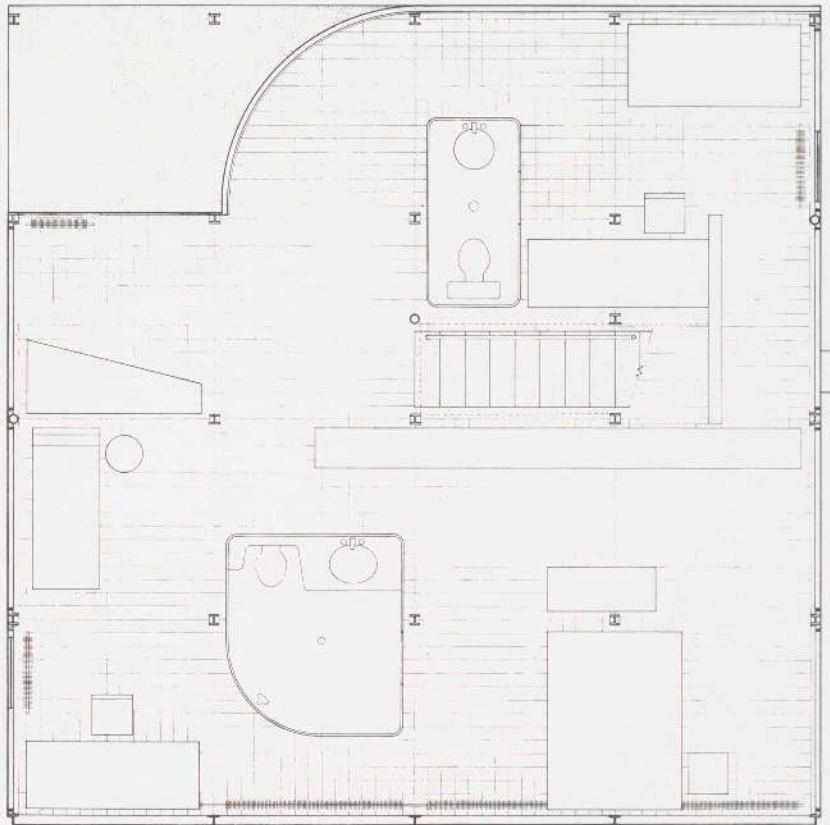

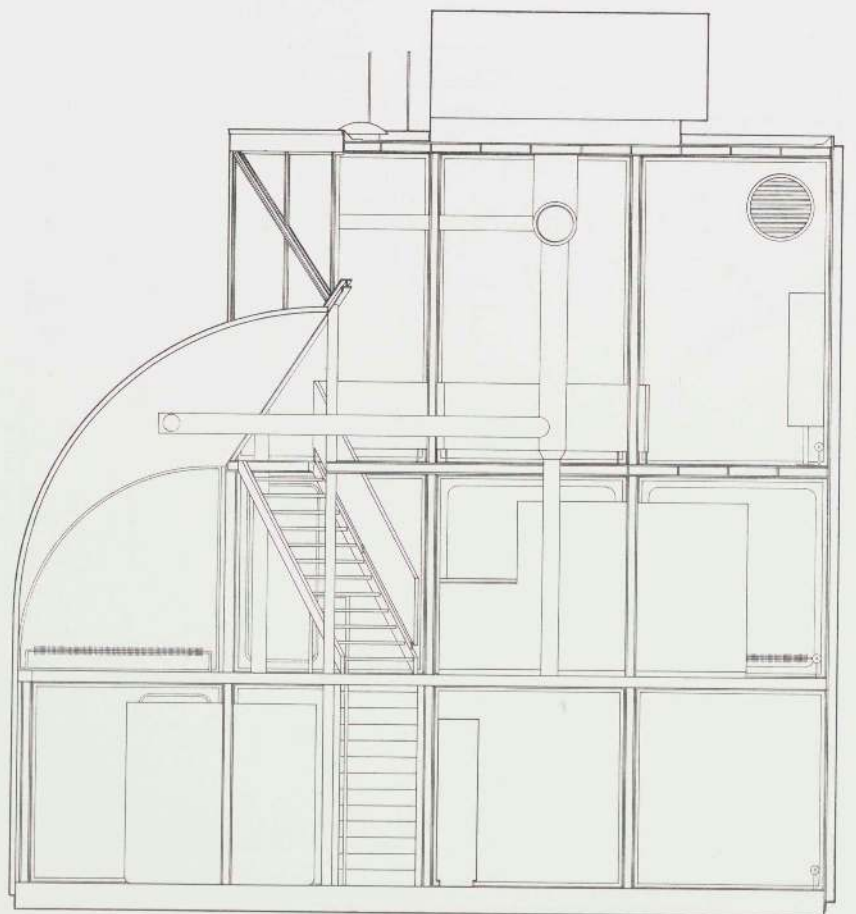
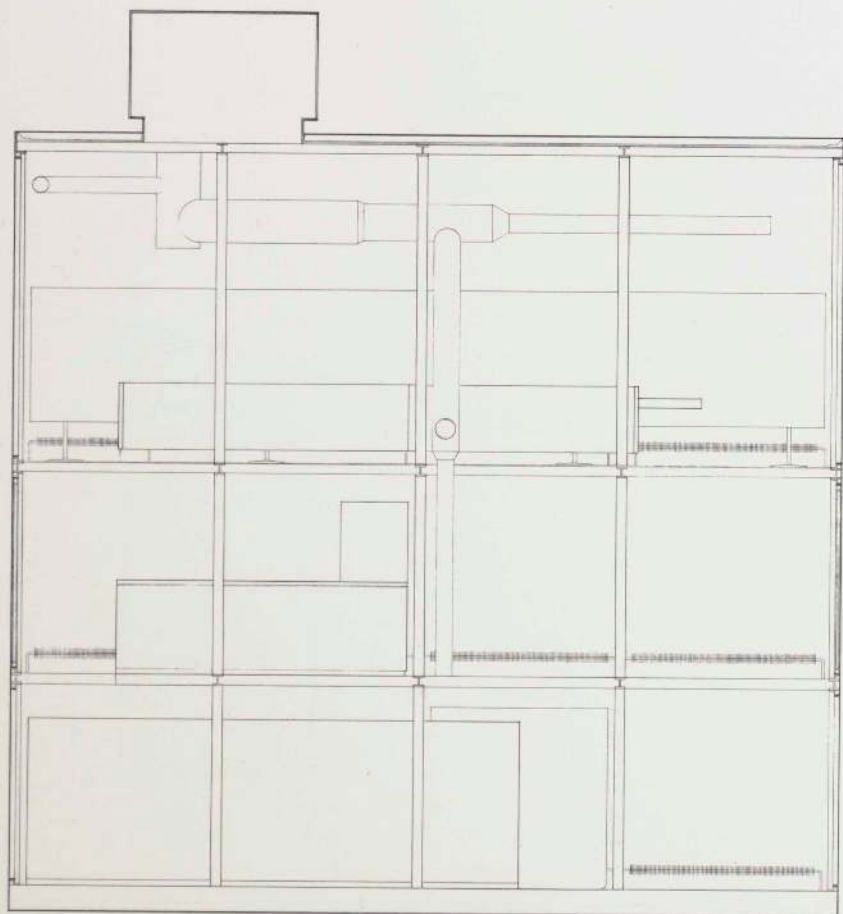
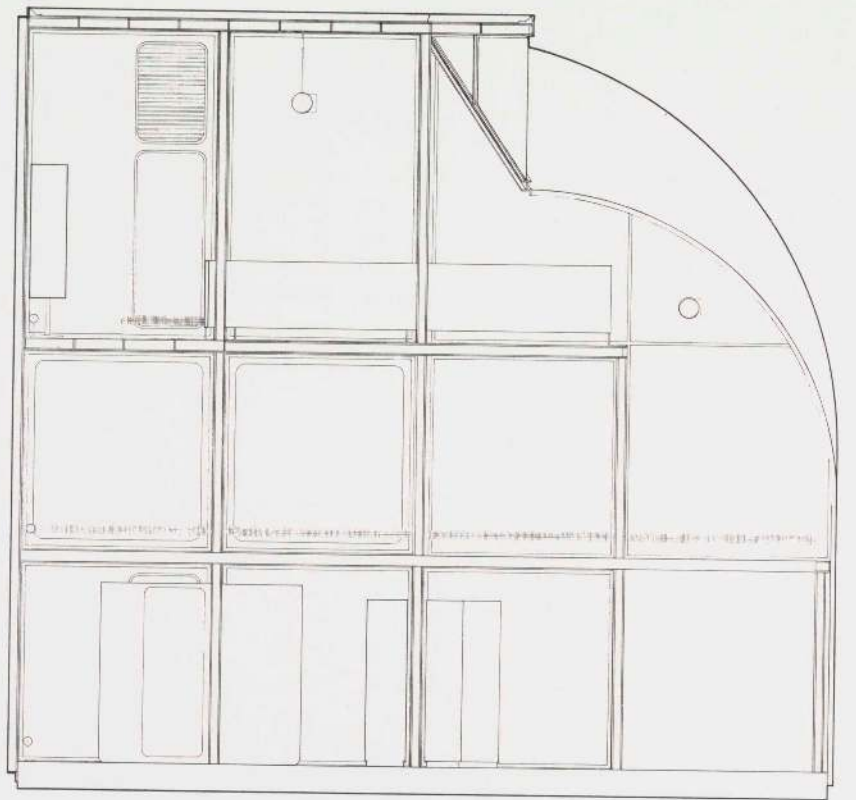
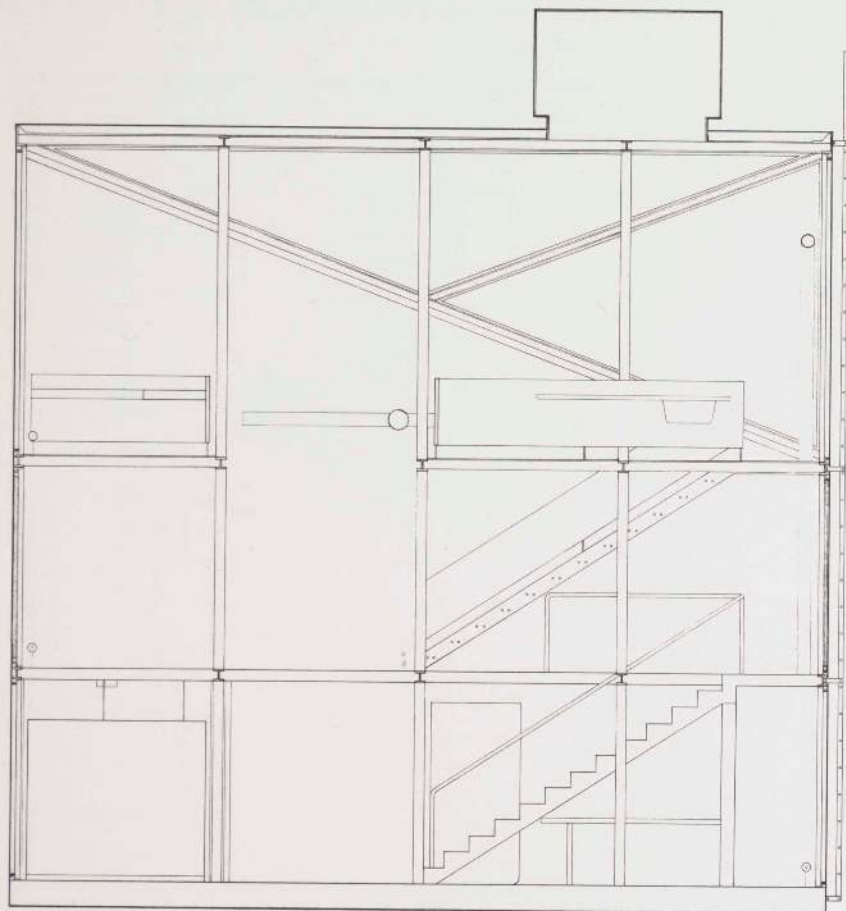

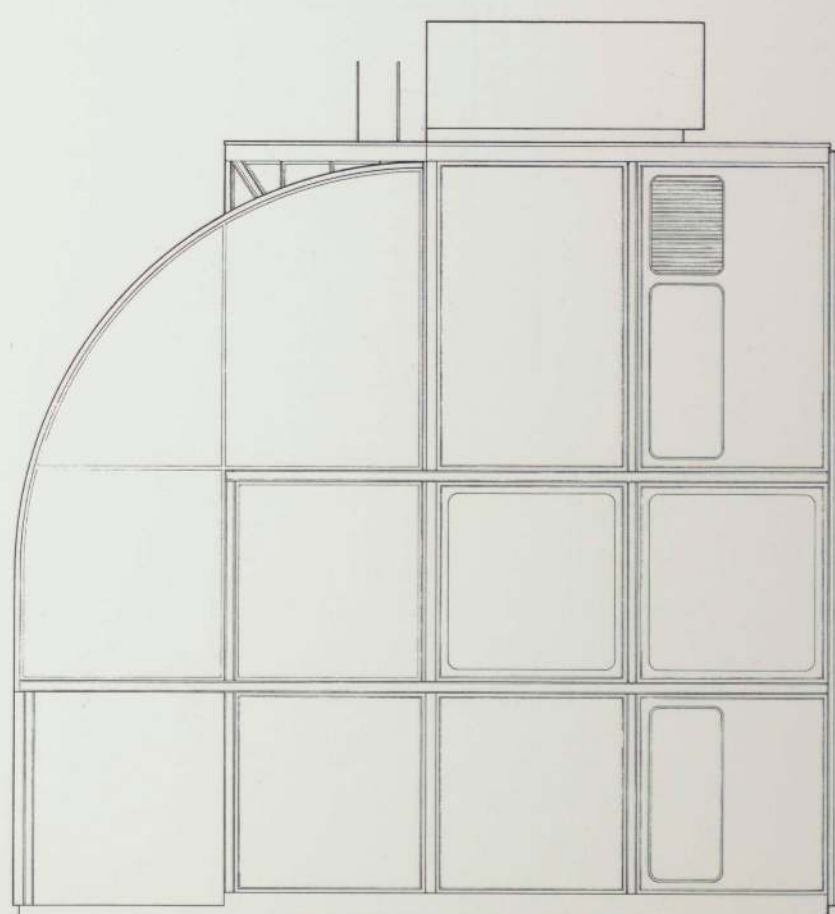
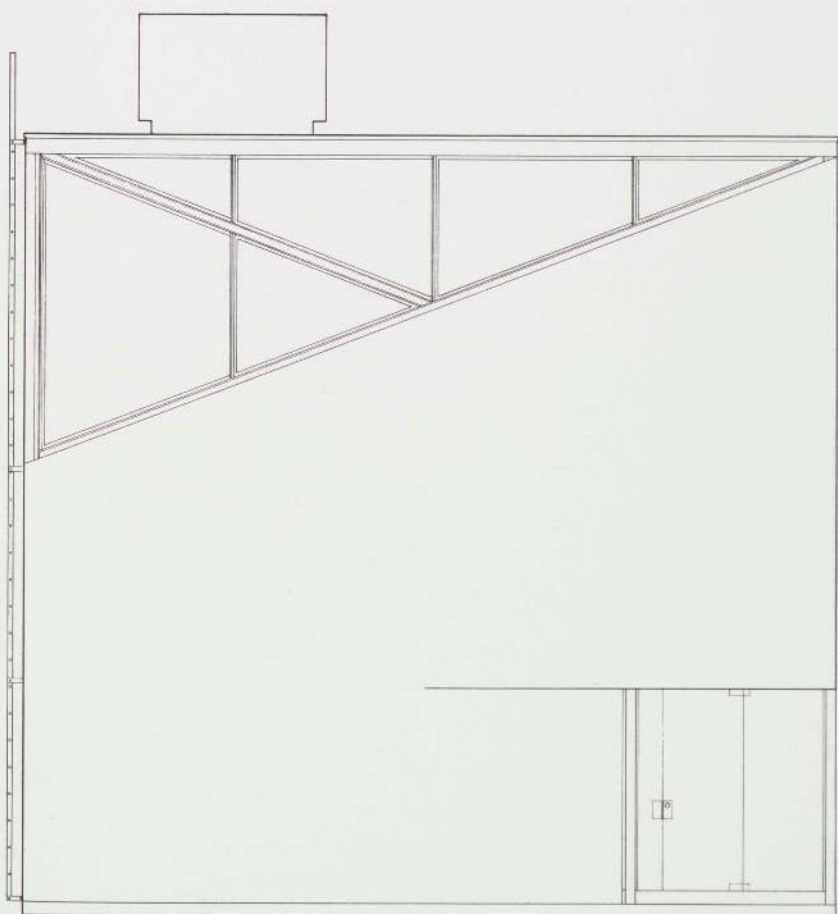
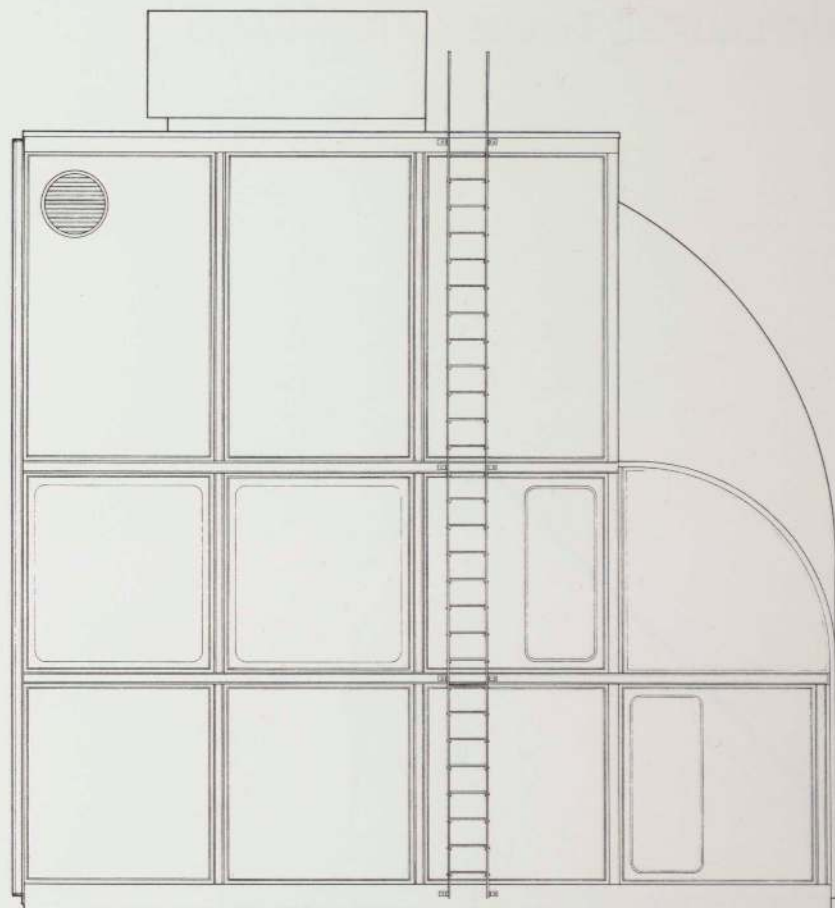
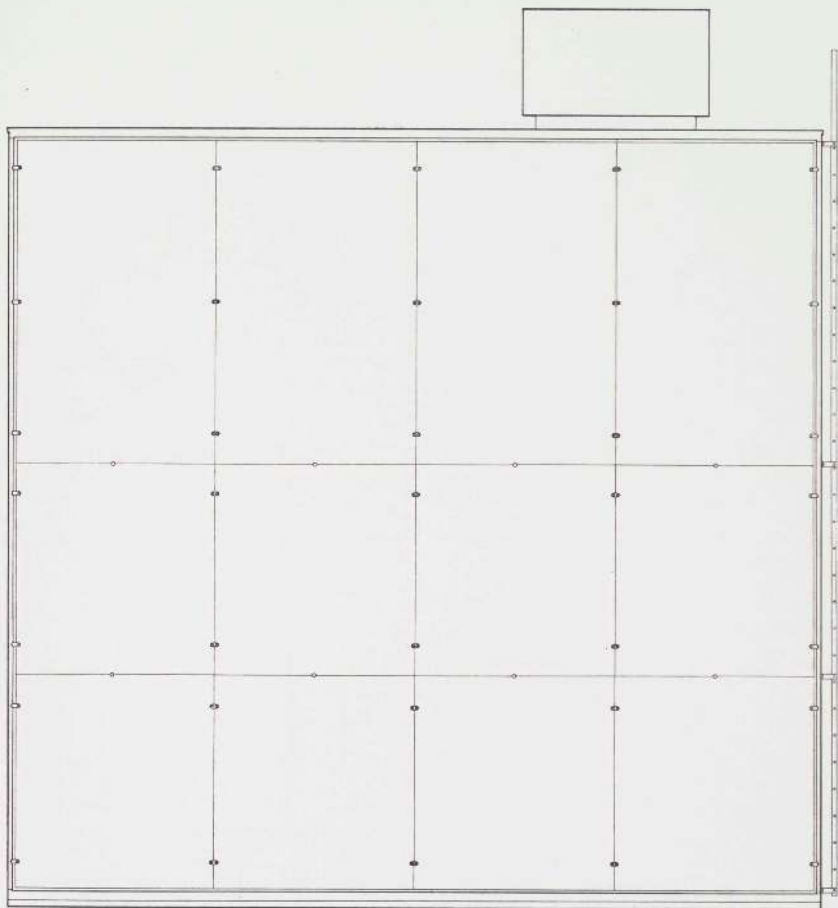

HOUSE/LAUREL LOVREK TRAVISANO.

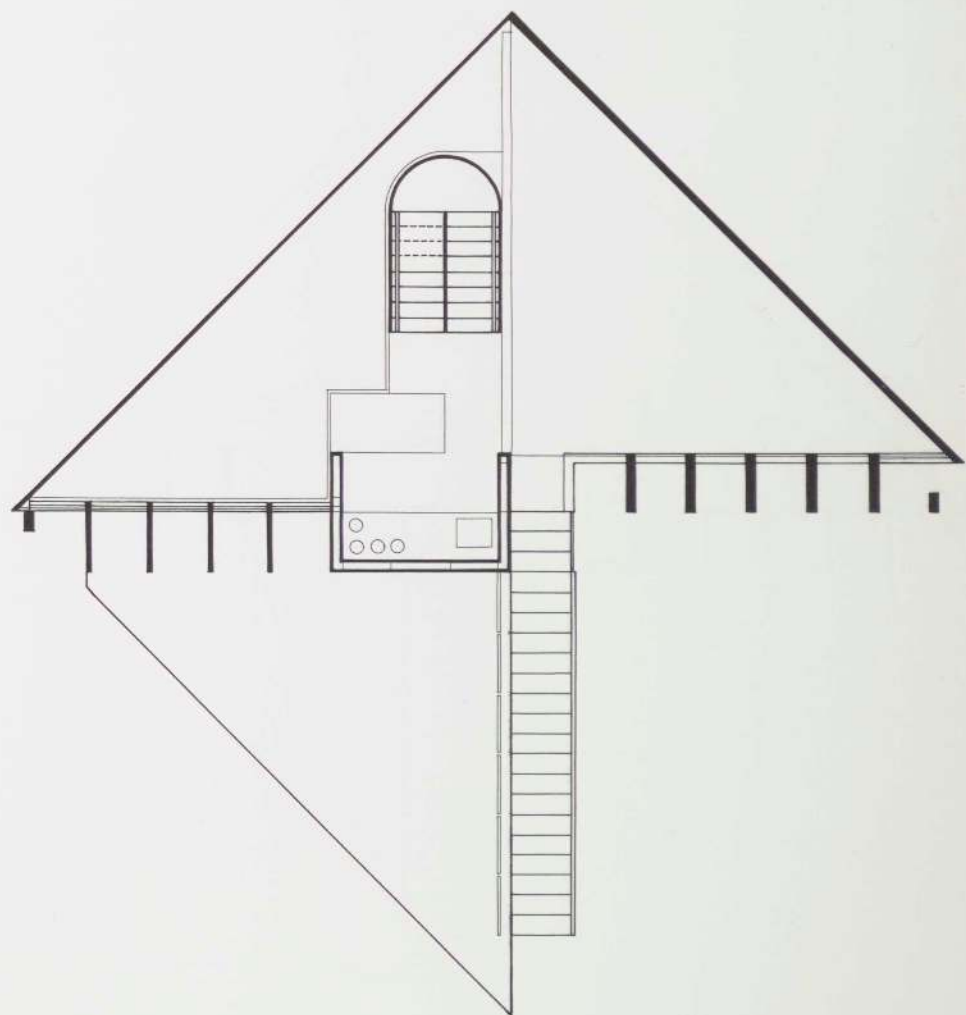
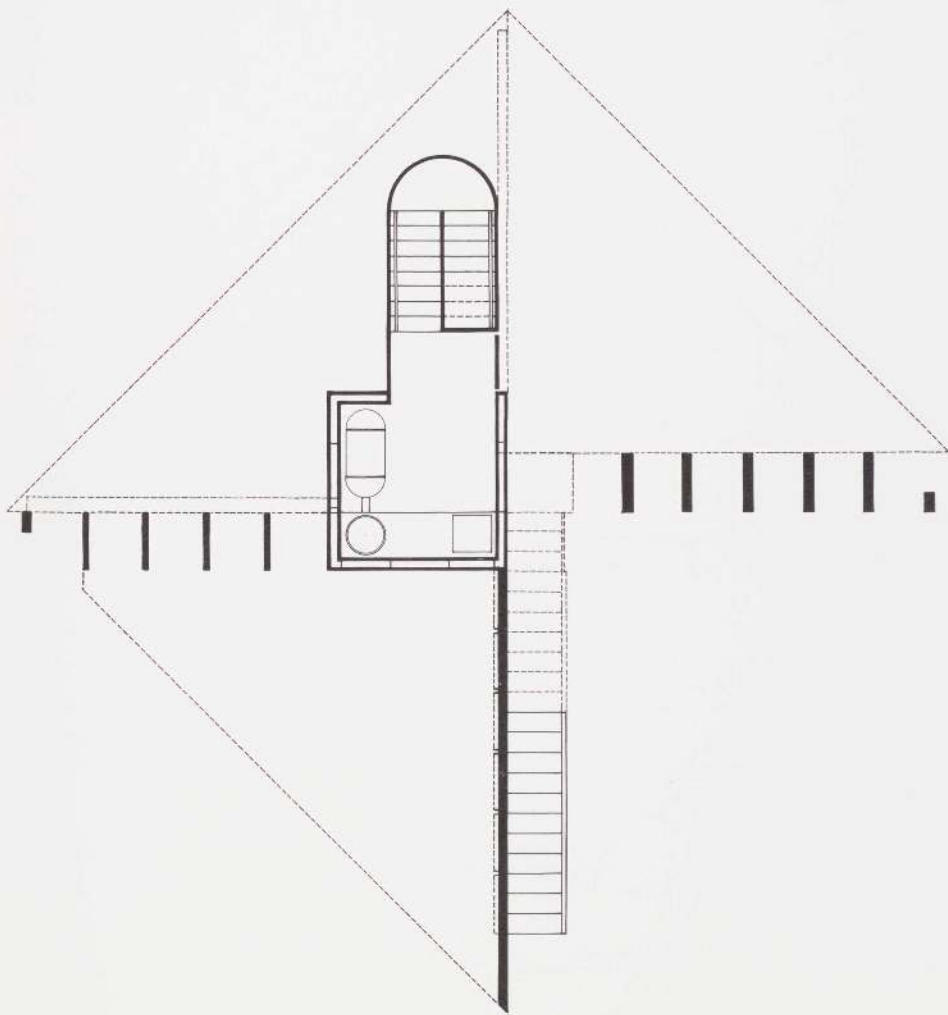

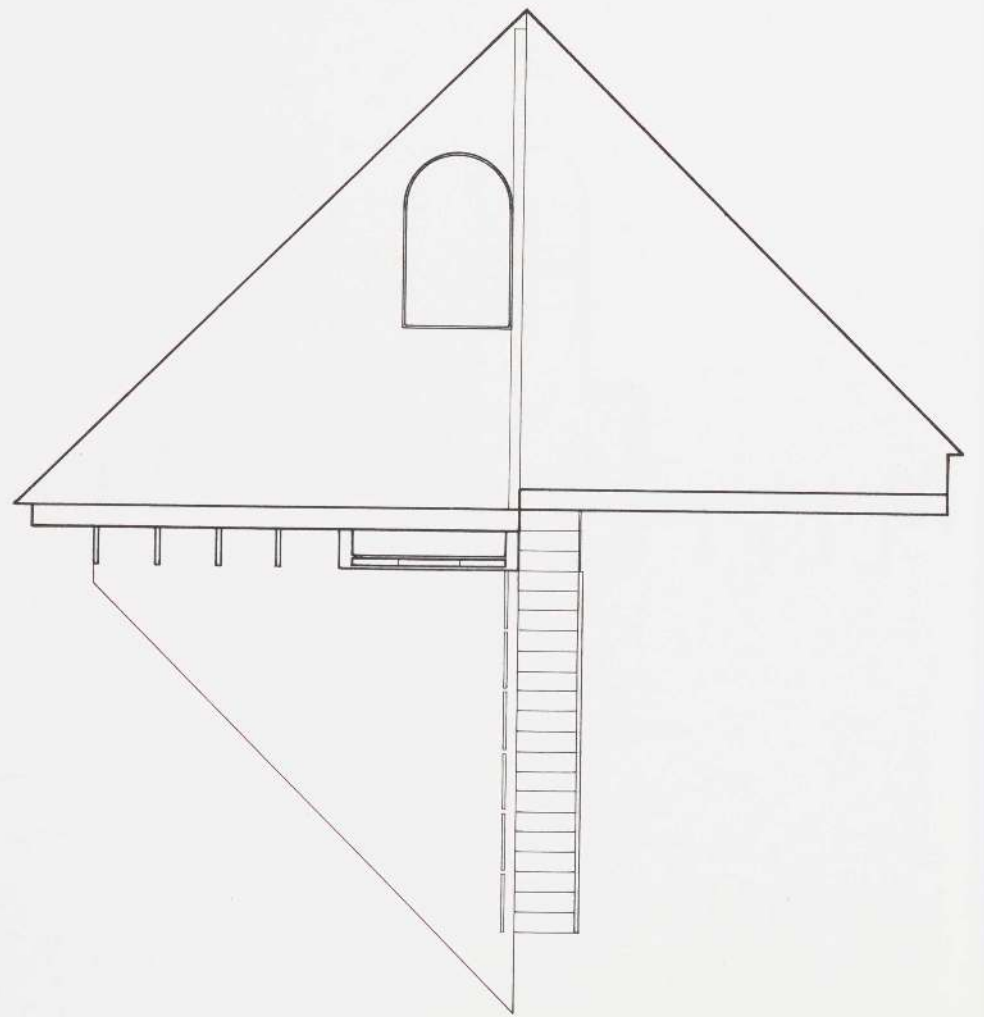
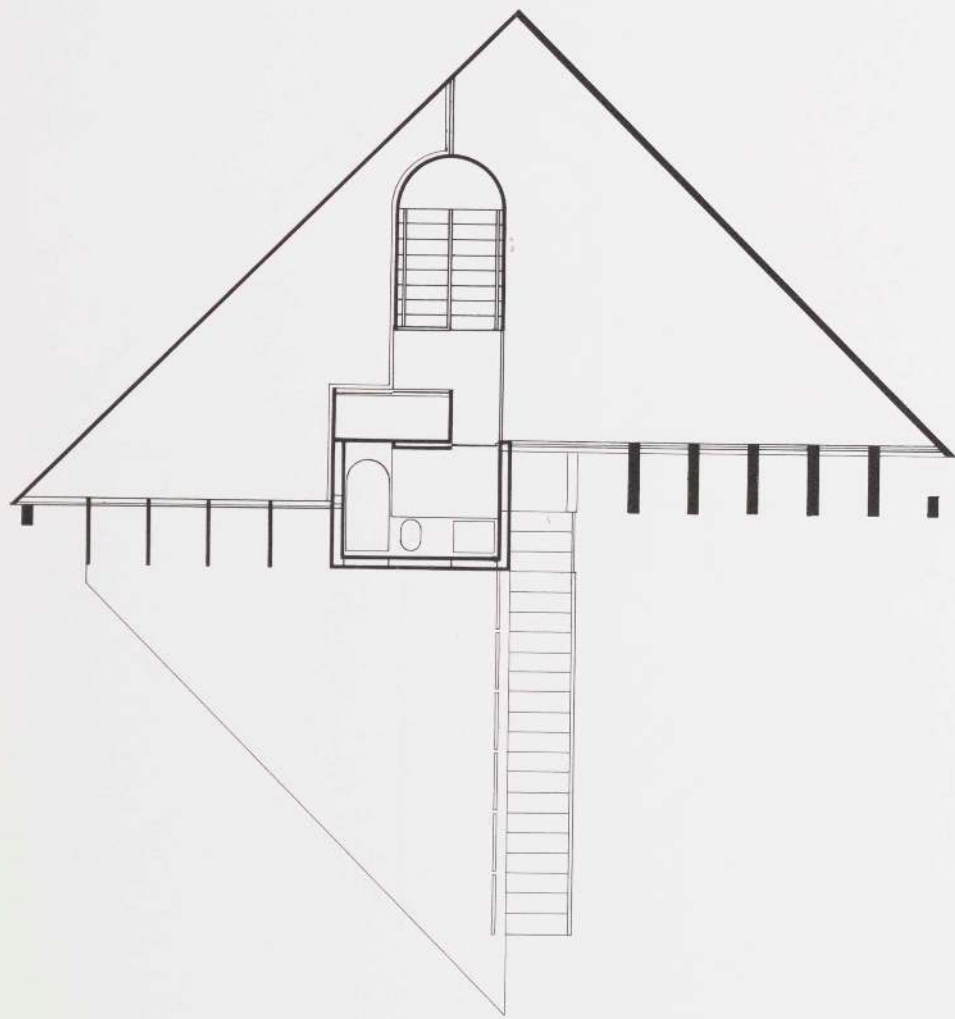

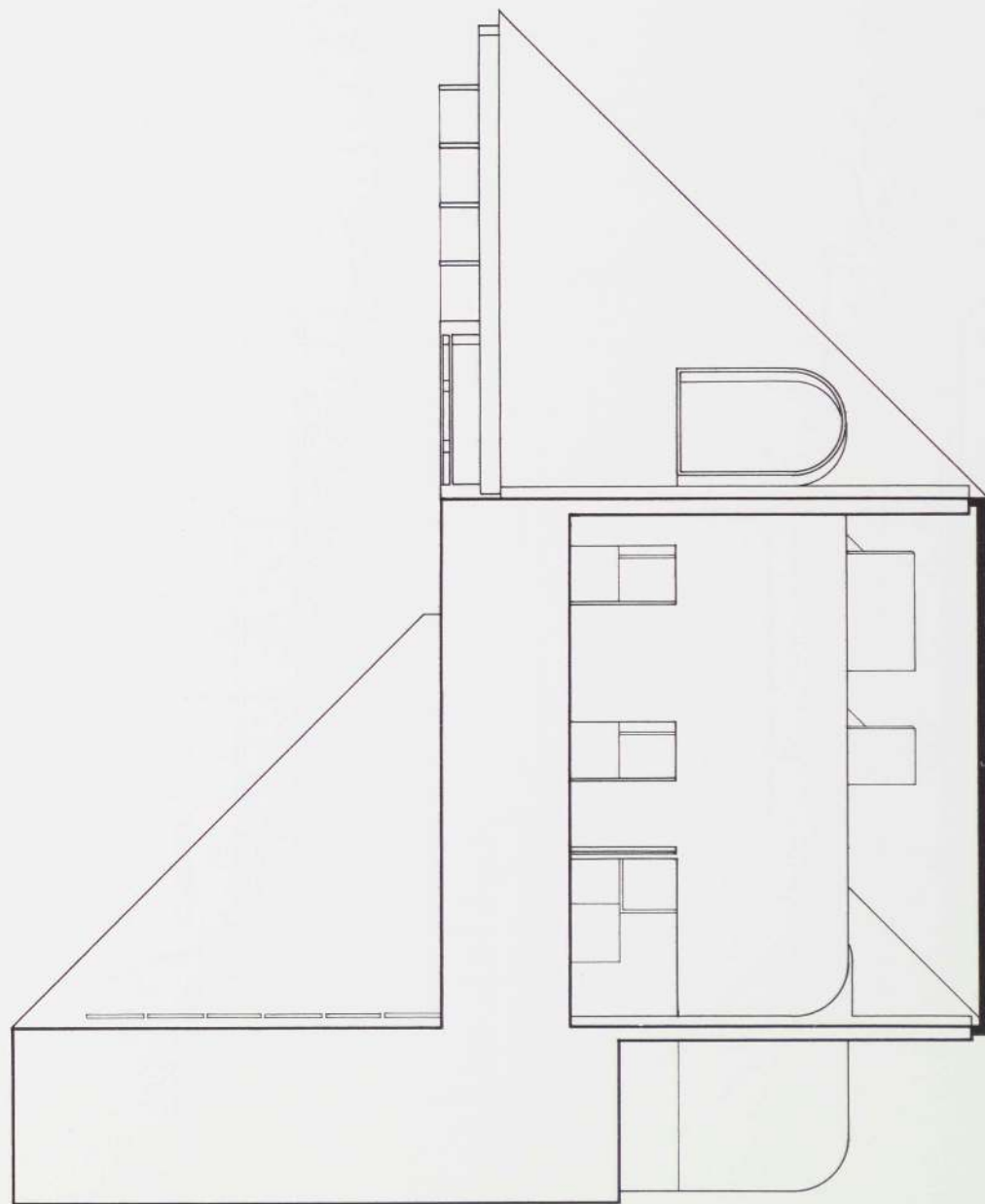

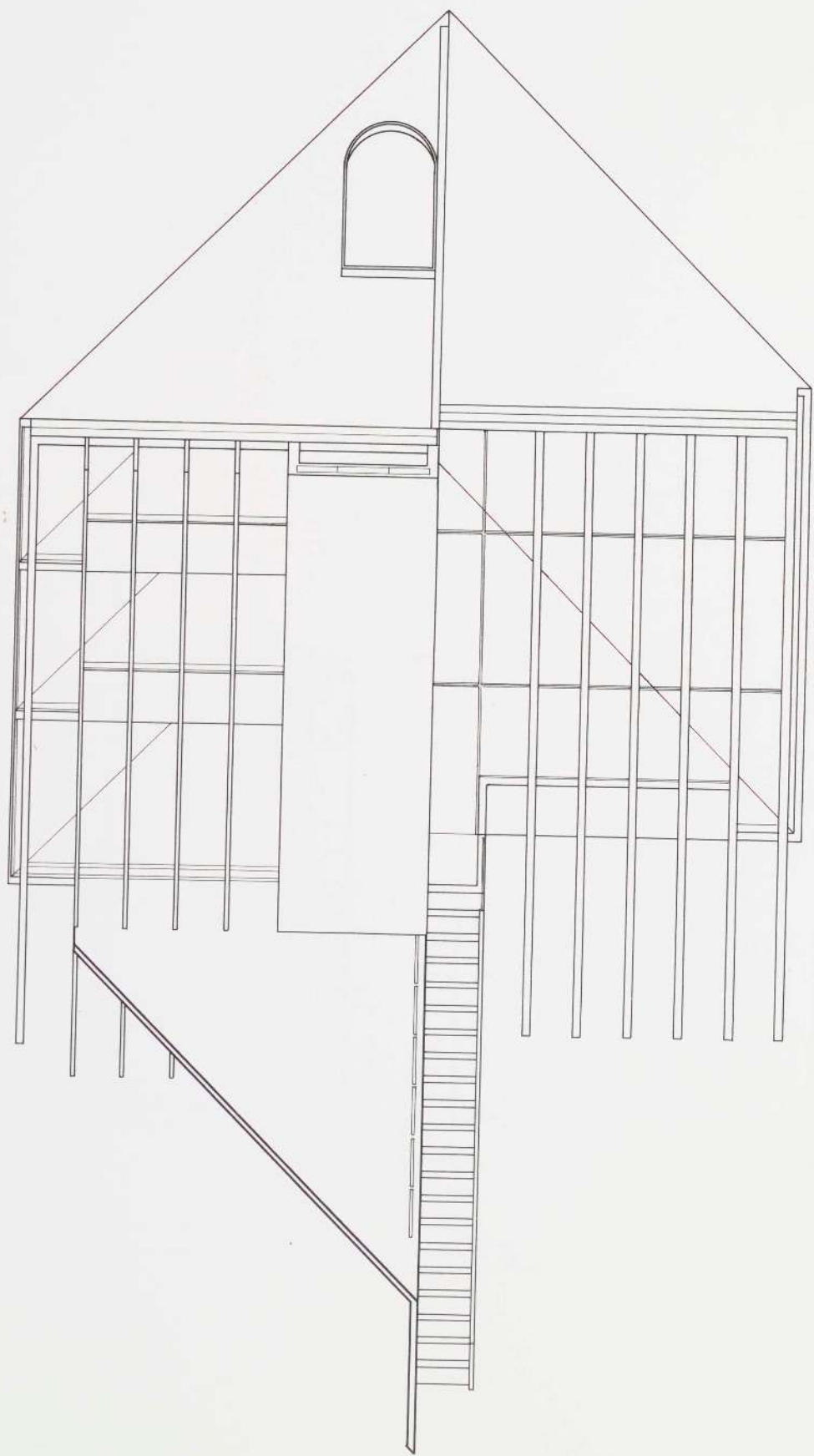

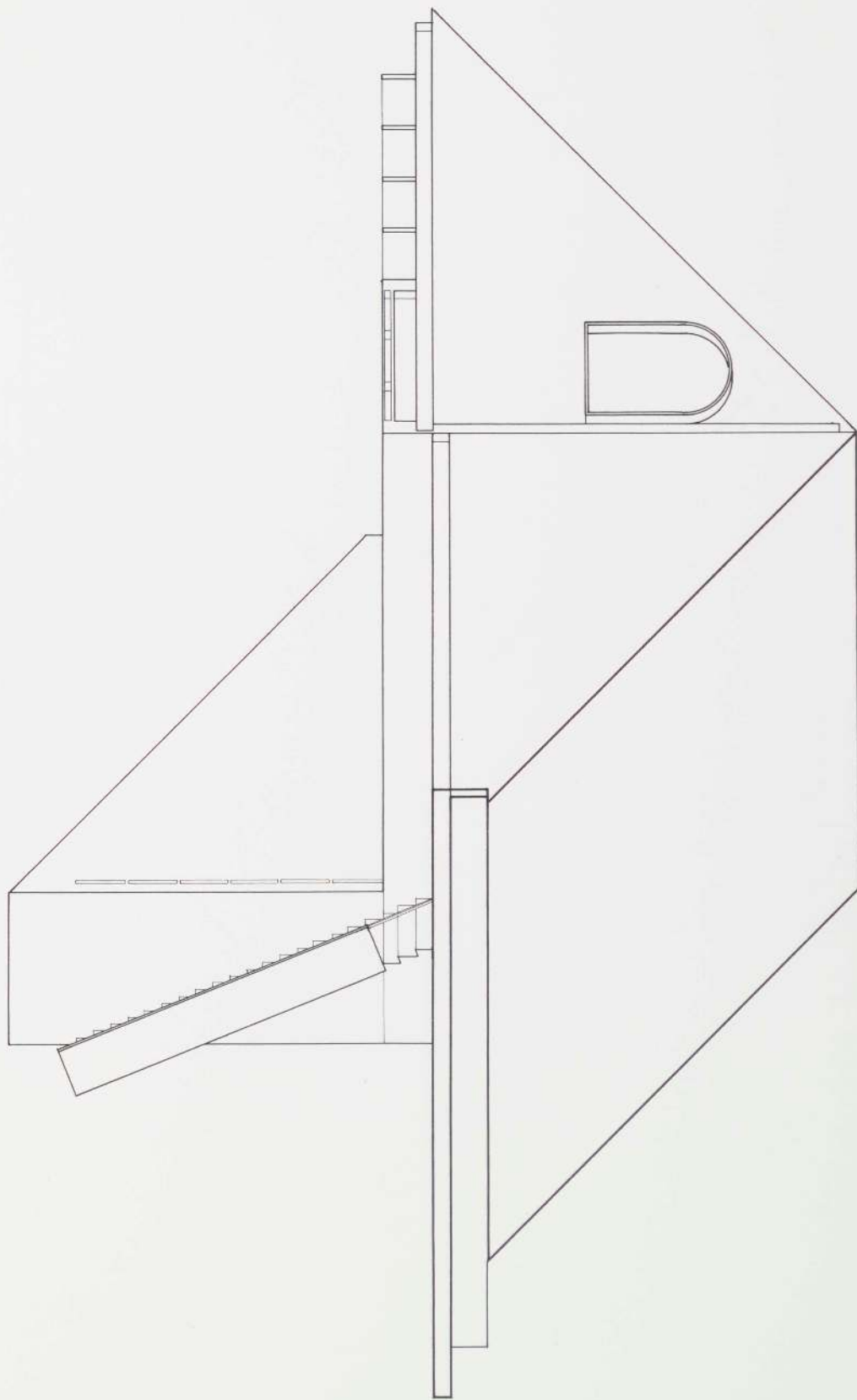

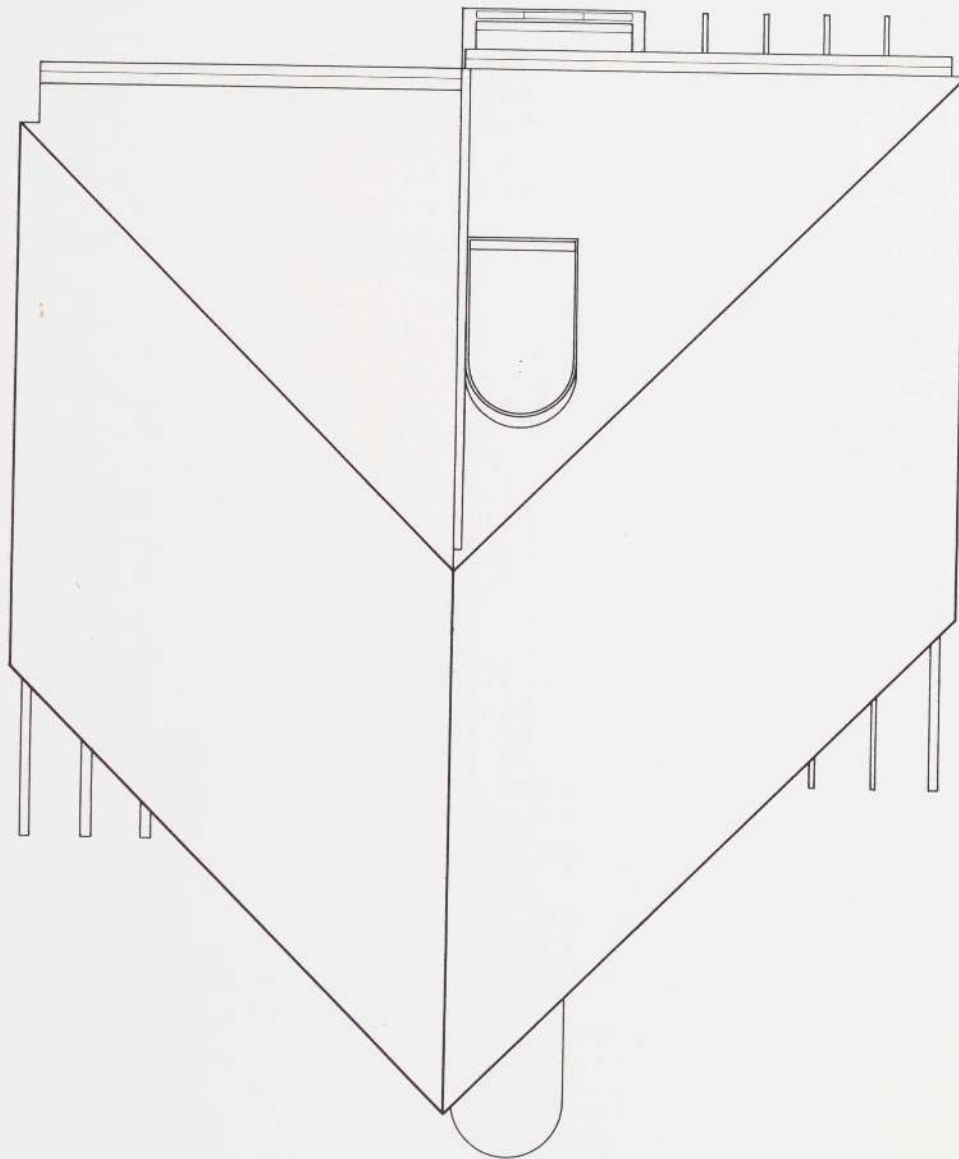

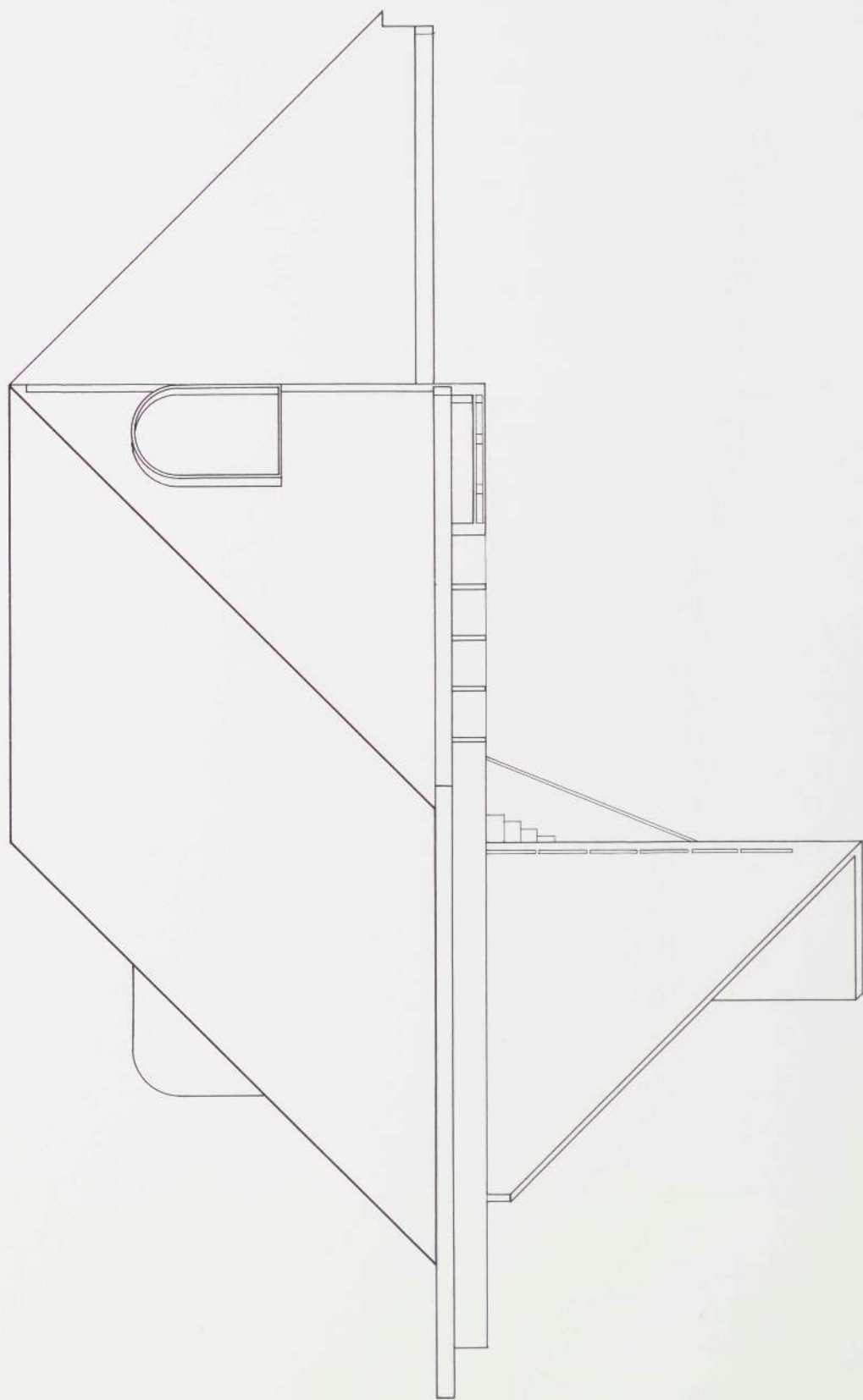

DIAMOND BUILDING/JAMES E. MILLER. When Mondrian tilted the frame of the square, he found an inherent dynamic quality to this form. Thus he was able, in his diamond paintings, to express an implied extension of the content into the field beyond the edges. In my projects for a diamond building, I have explored the architectural ramifications of this gesture. It is perhaps significant that although the idea for these projects emanated from my course of study at The Cooper Union, I became sufficiently intrigued to continue it as my graduate thesis at Columbia University.

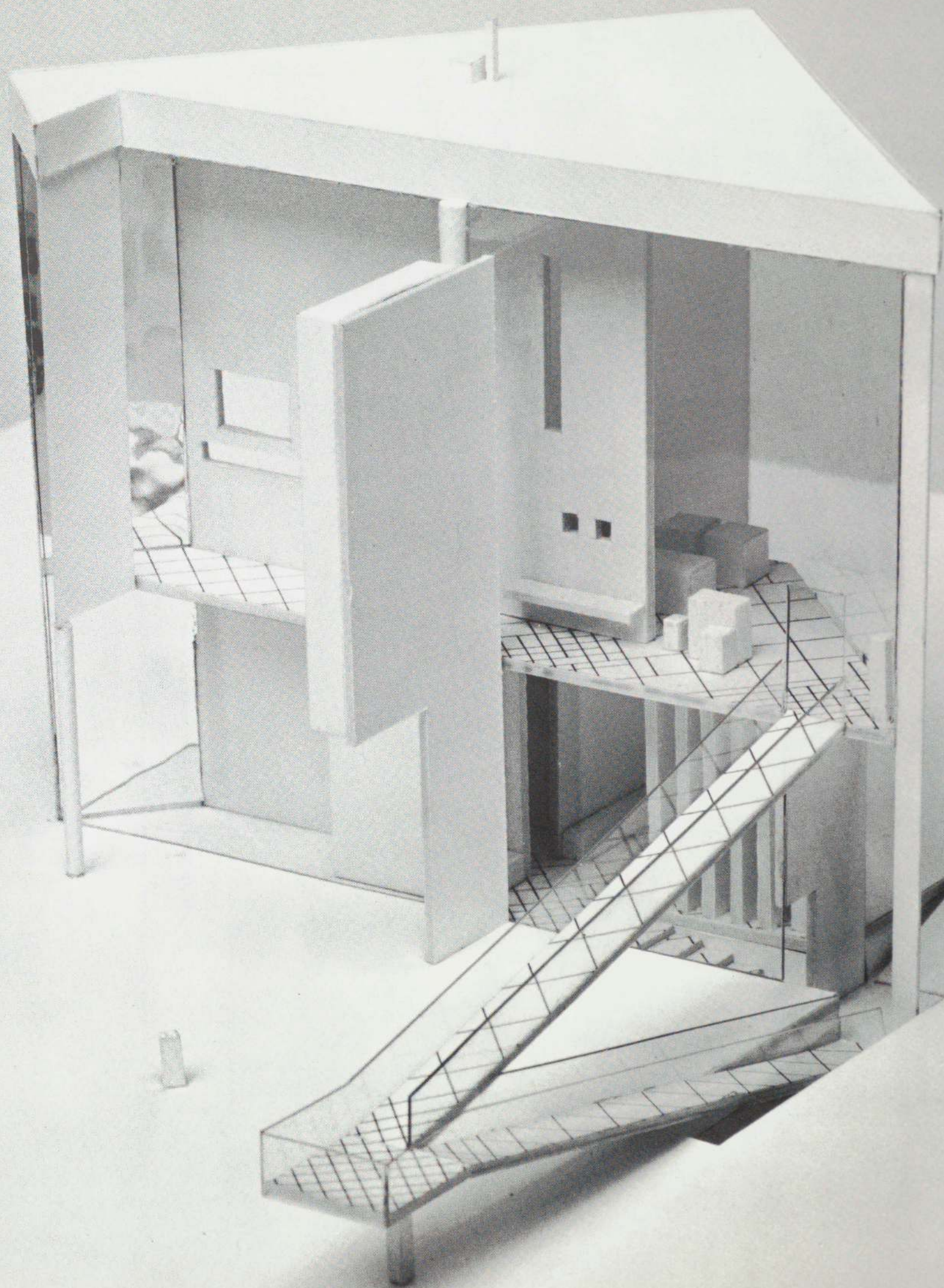

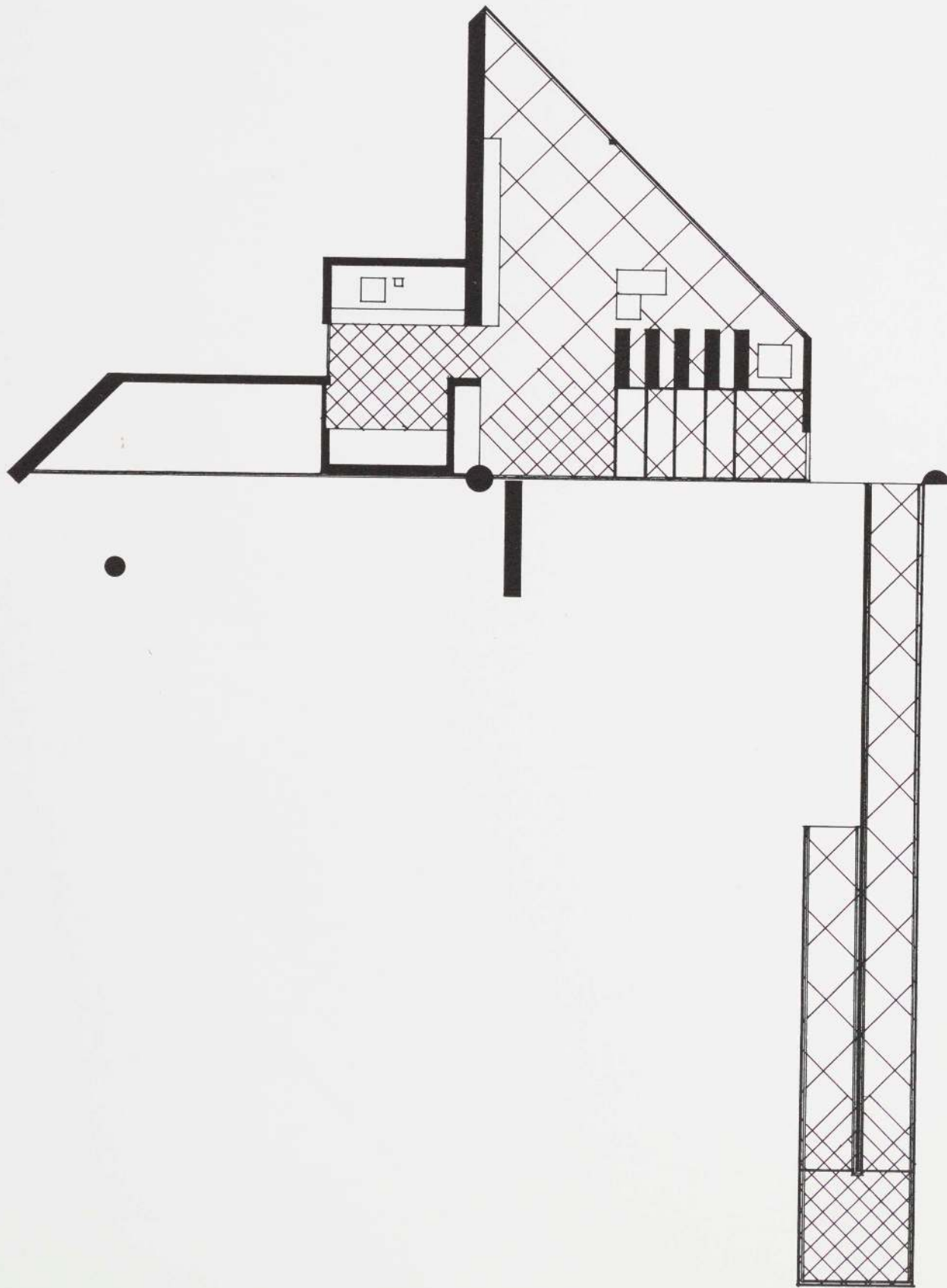

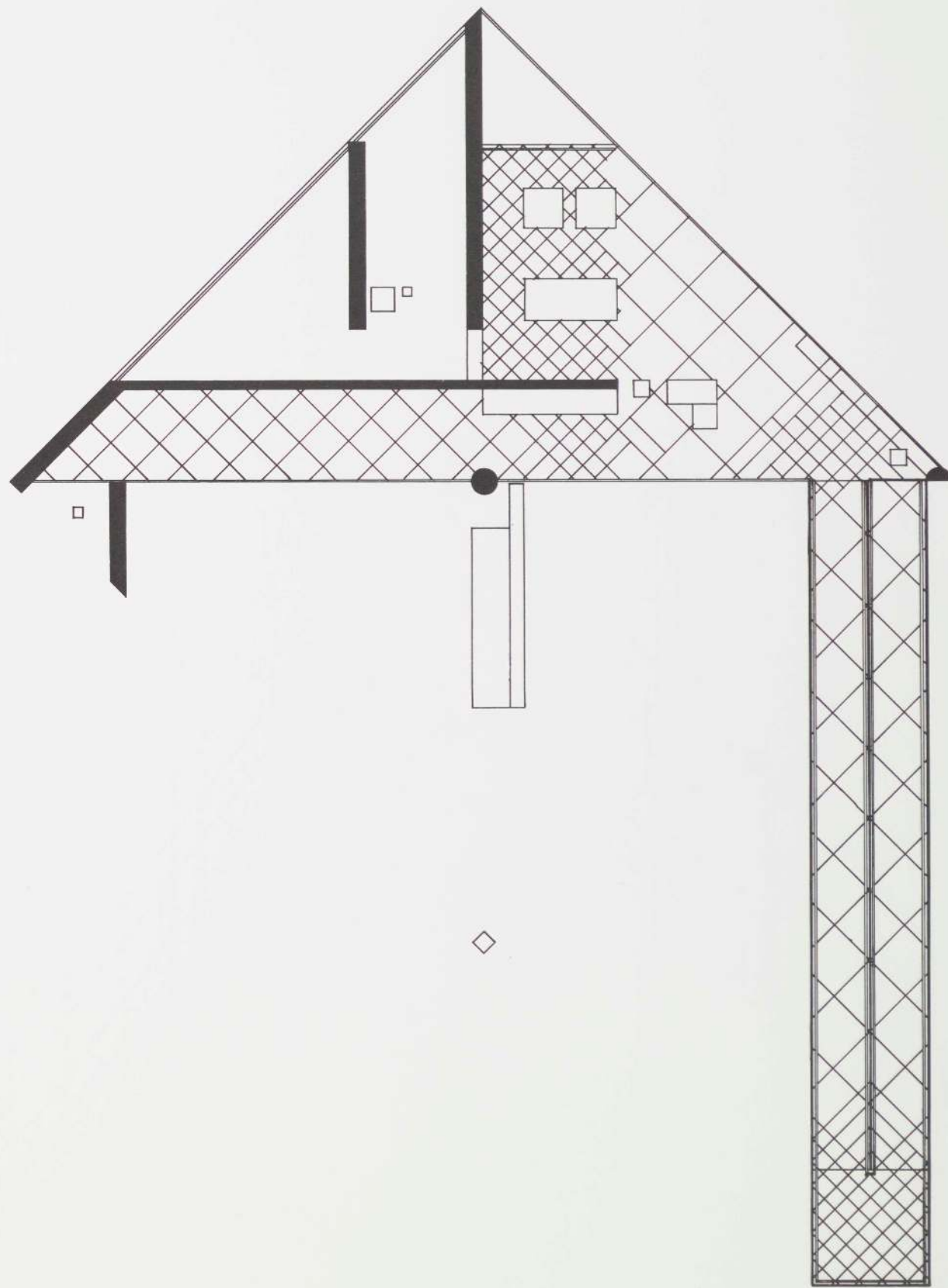

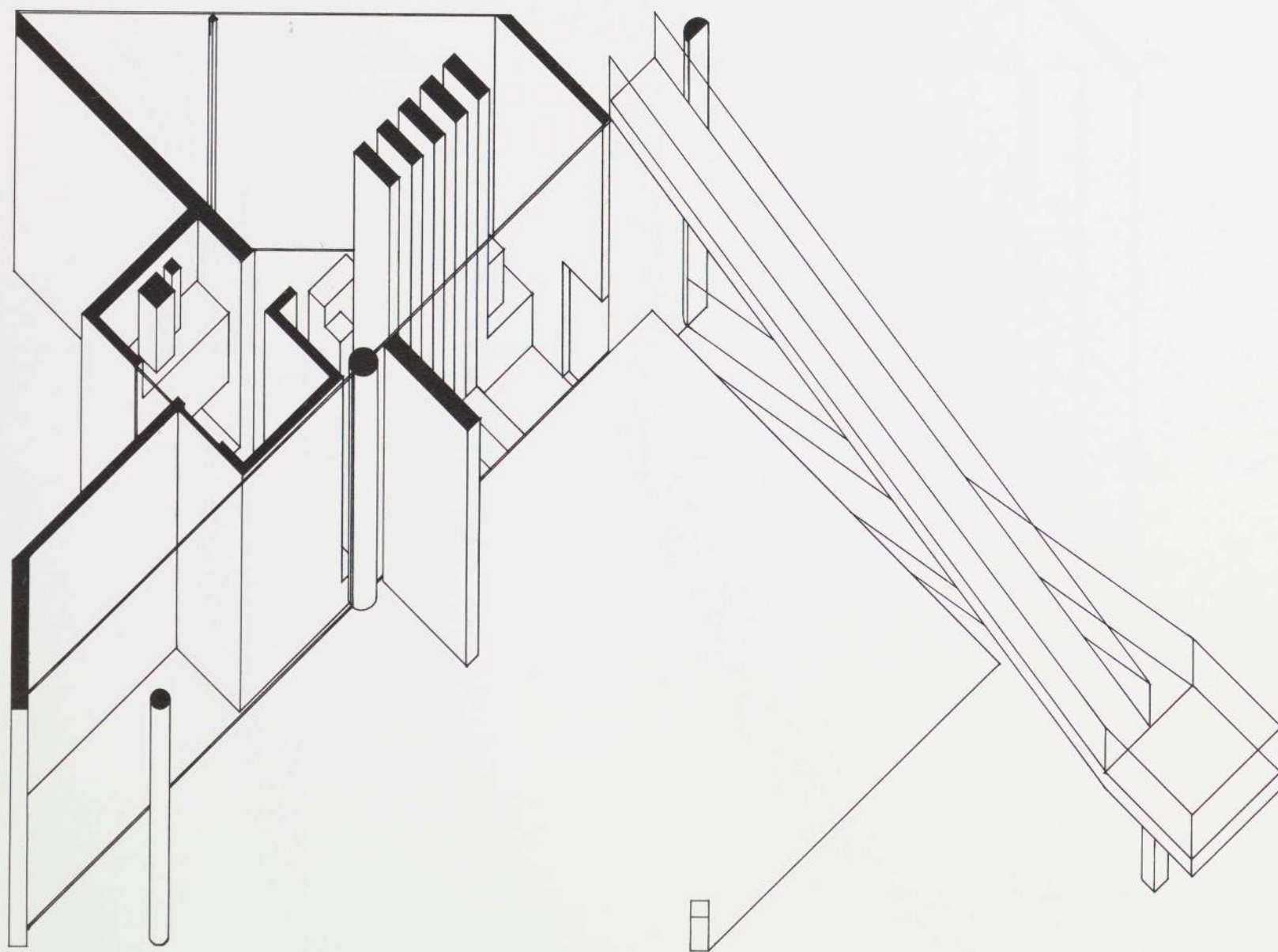

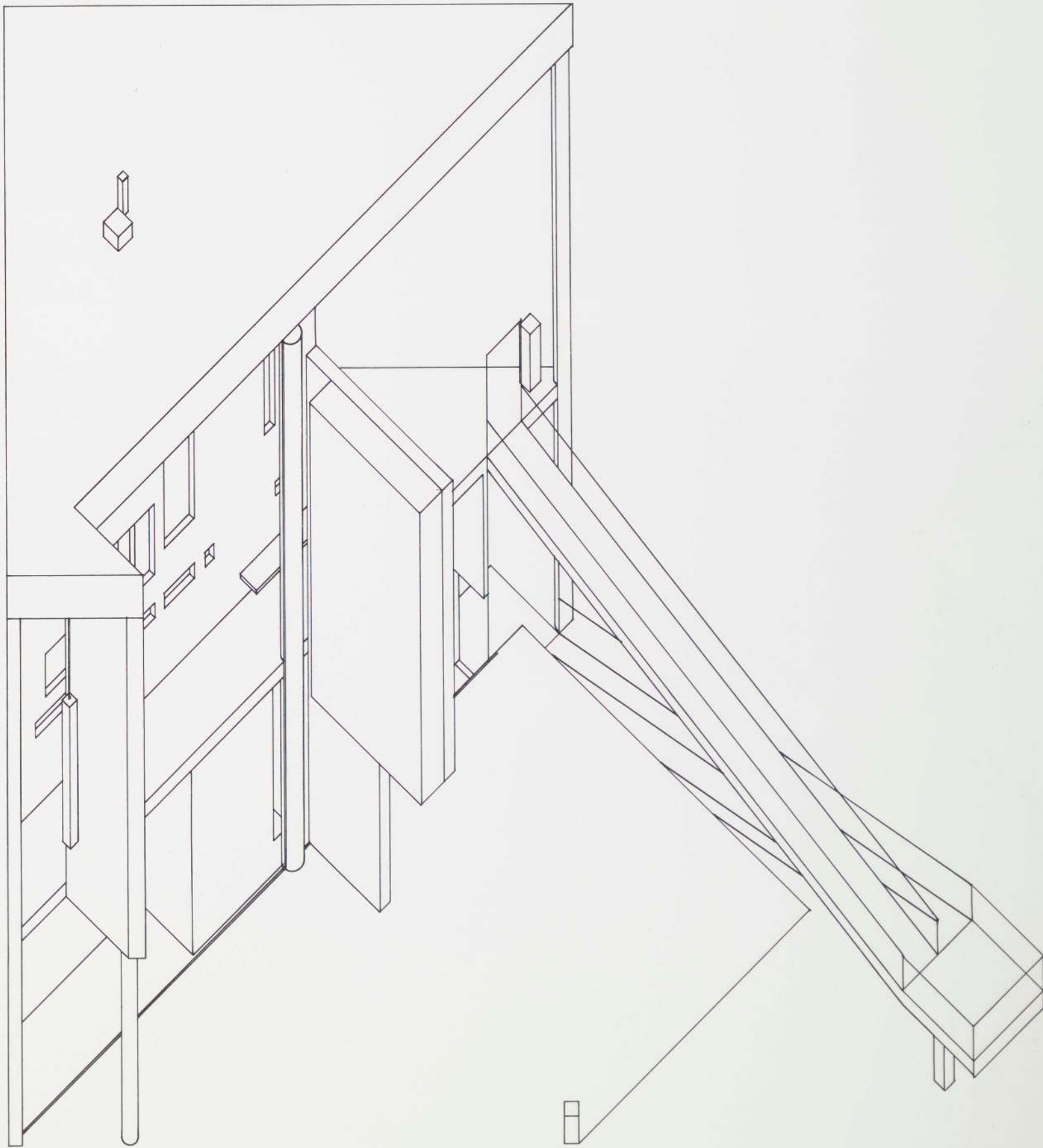

HOUSE/FRED TRAVISANO.

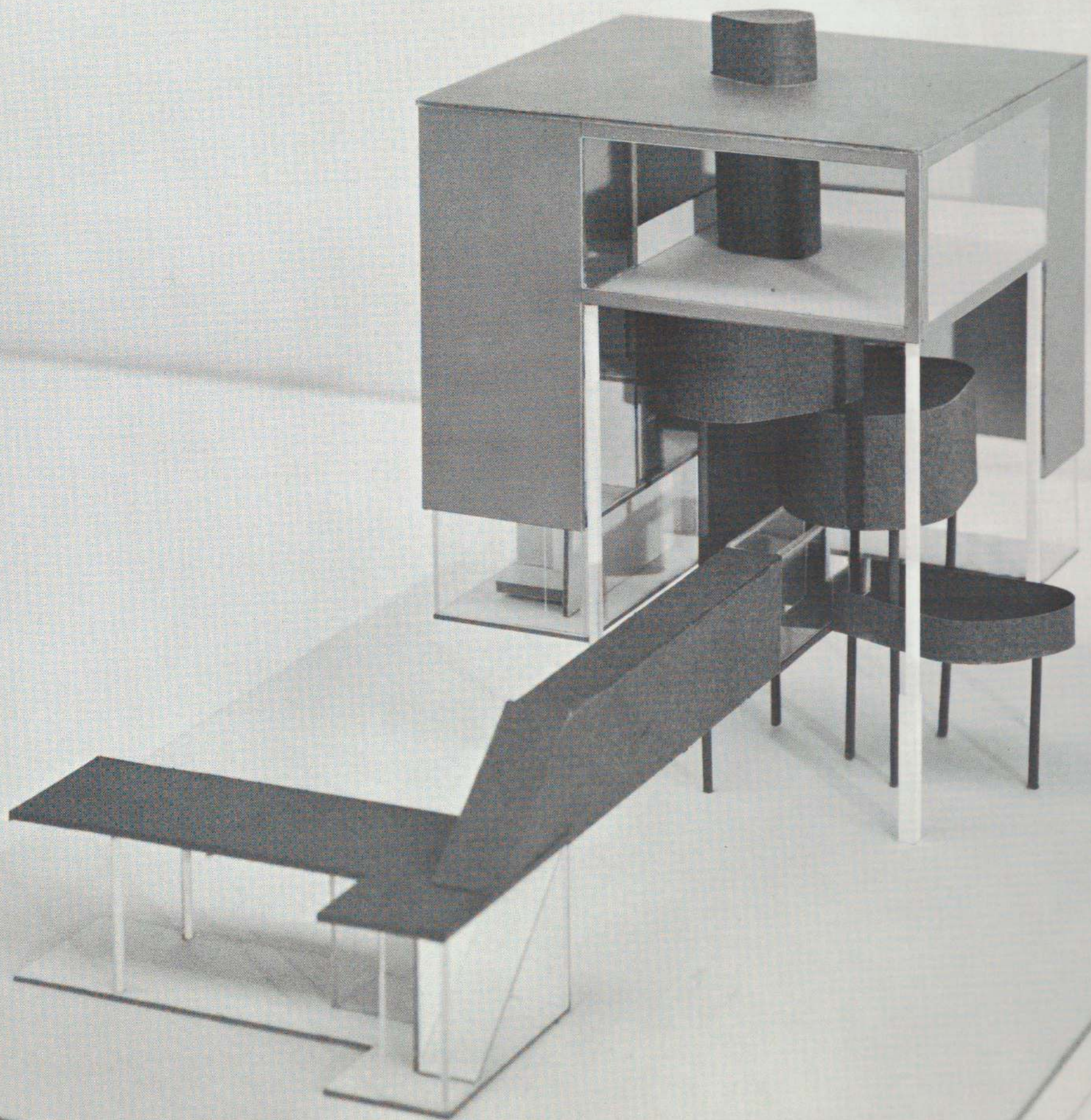

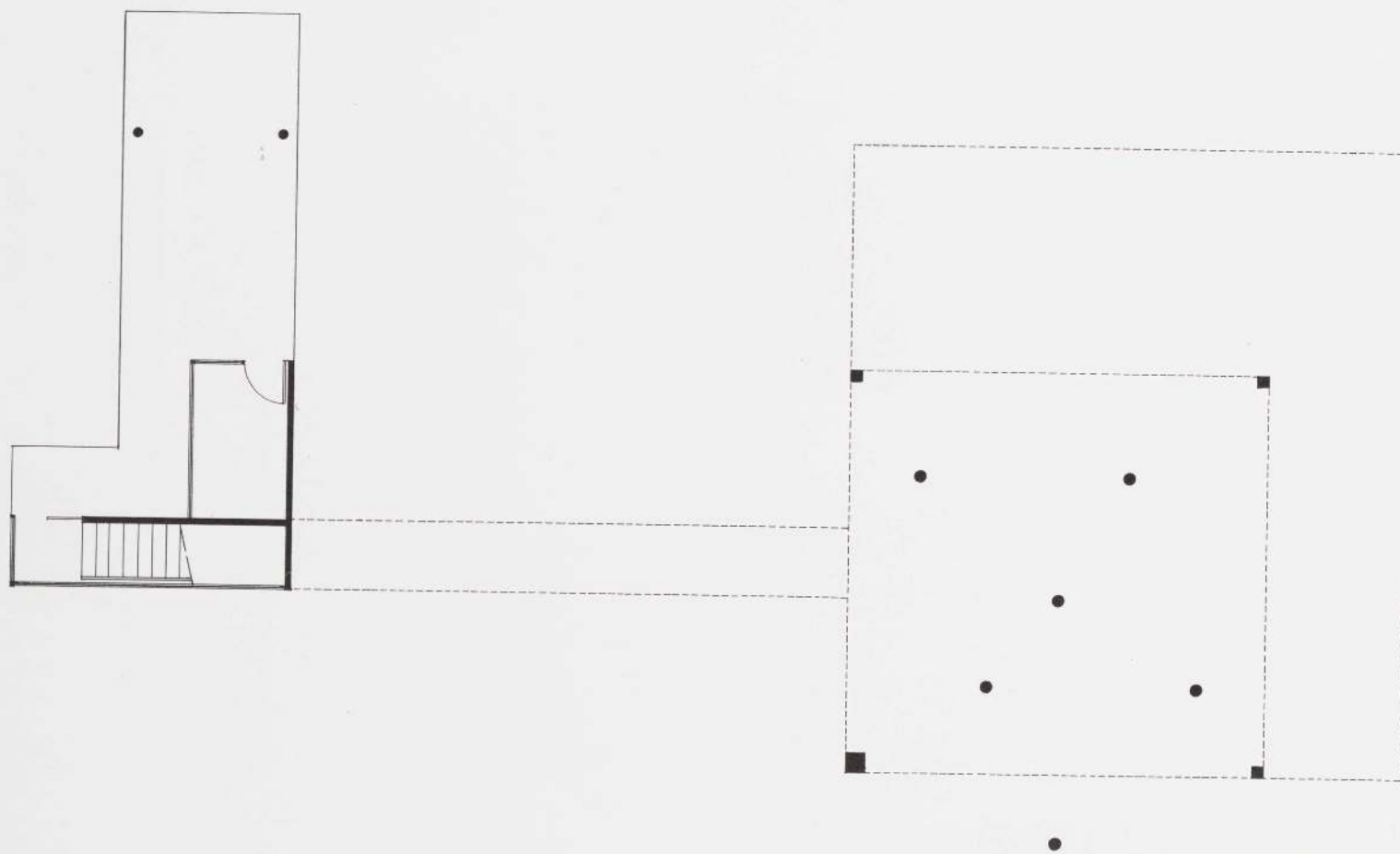

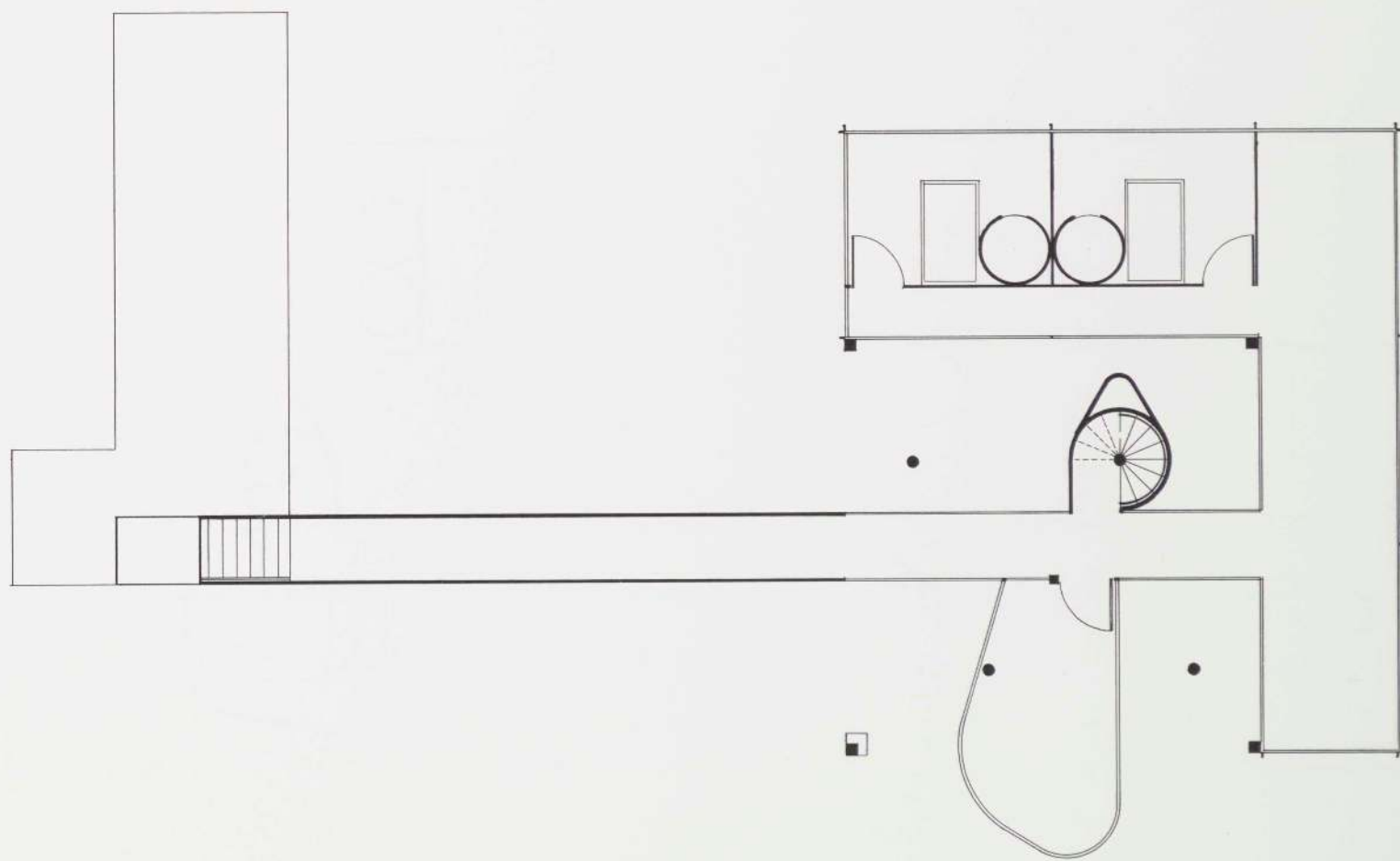

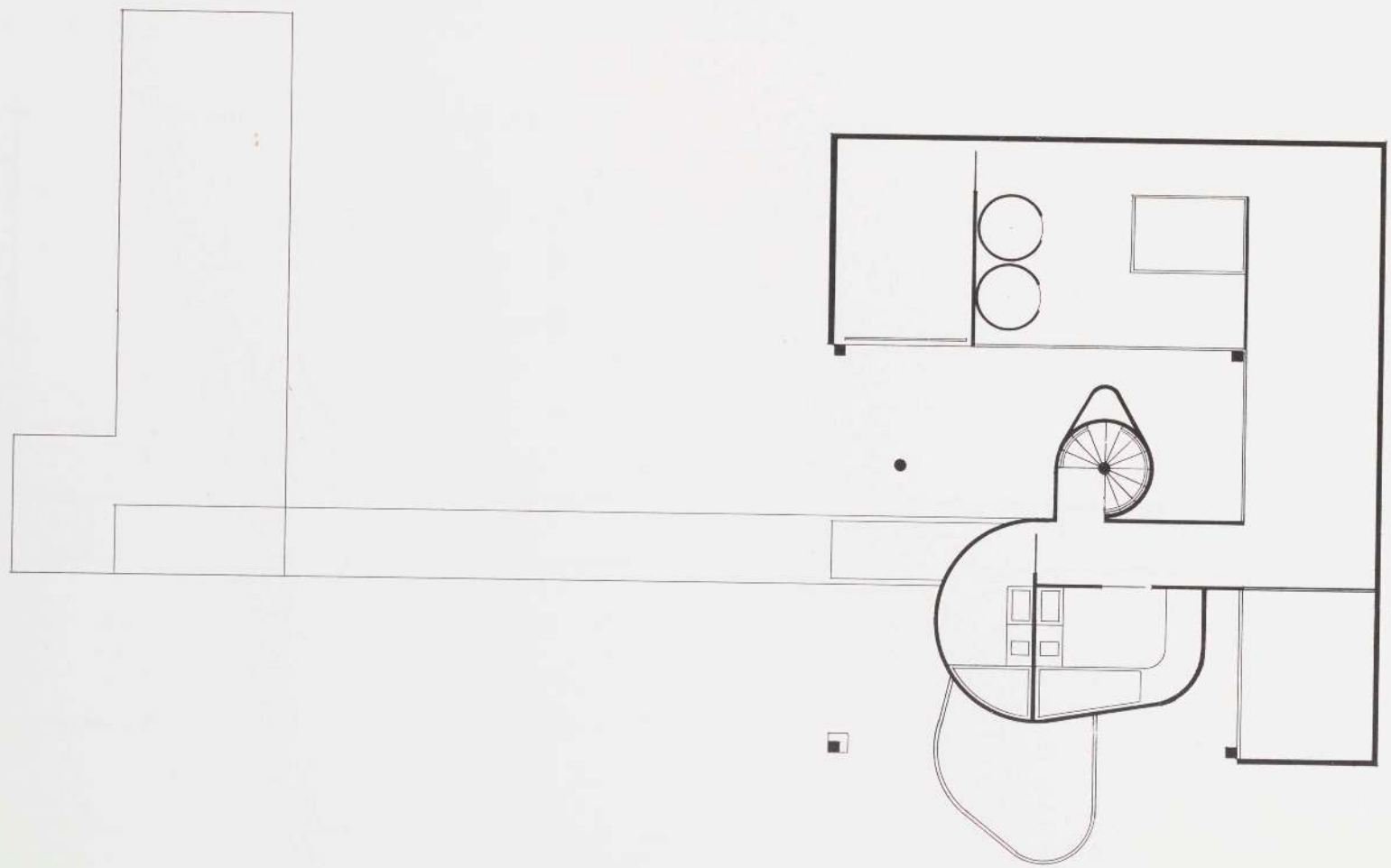

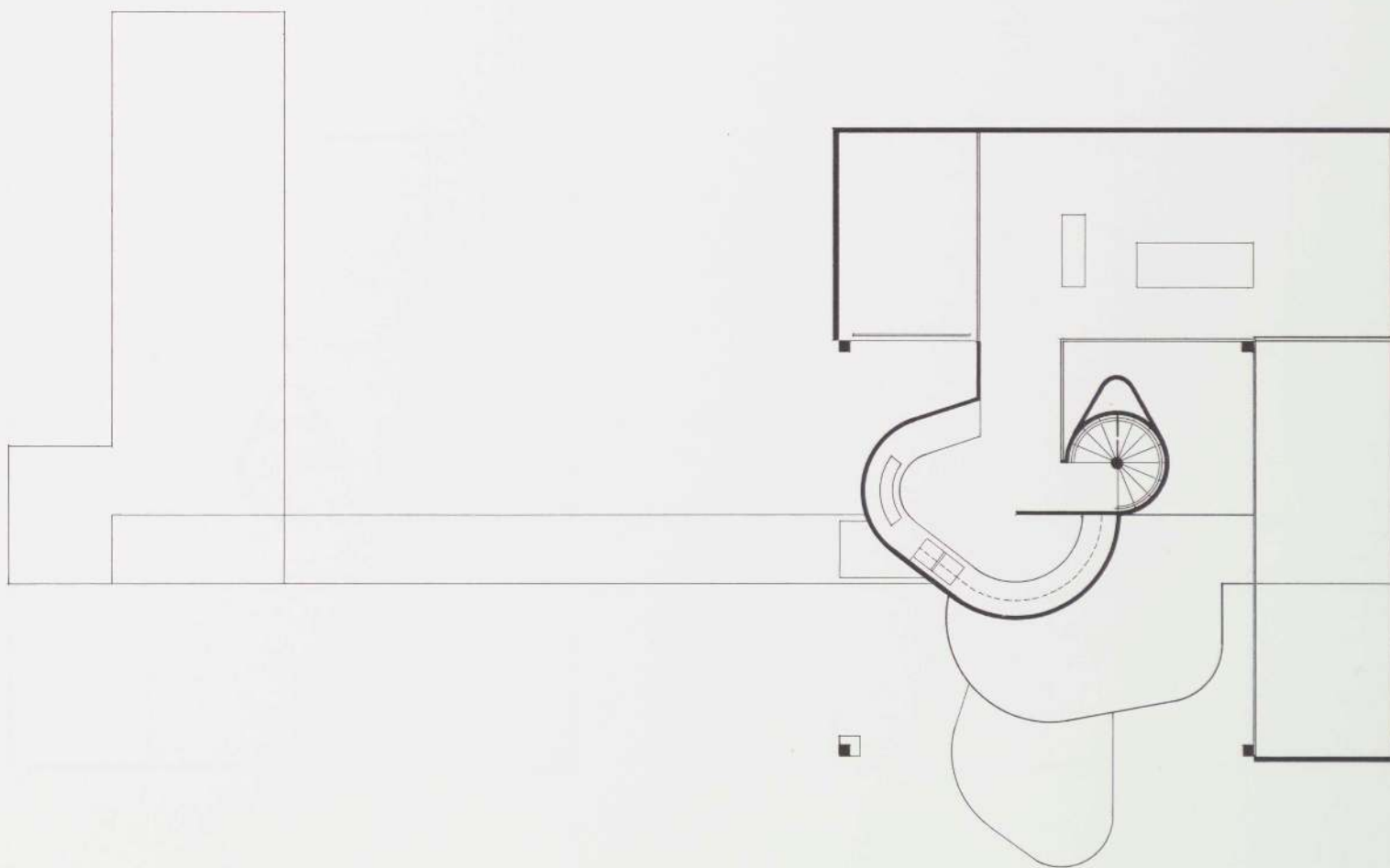

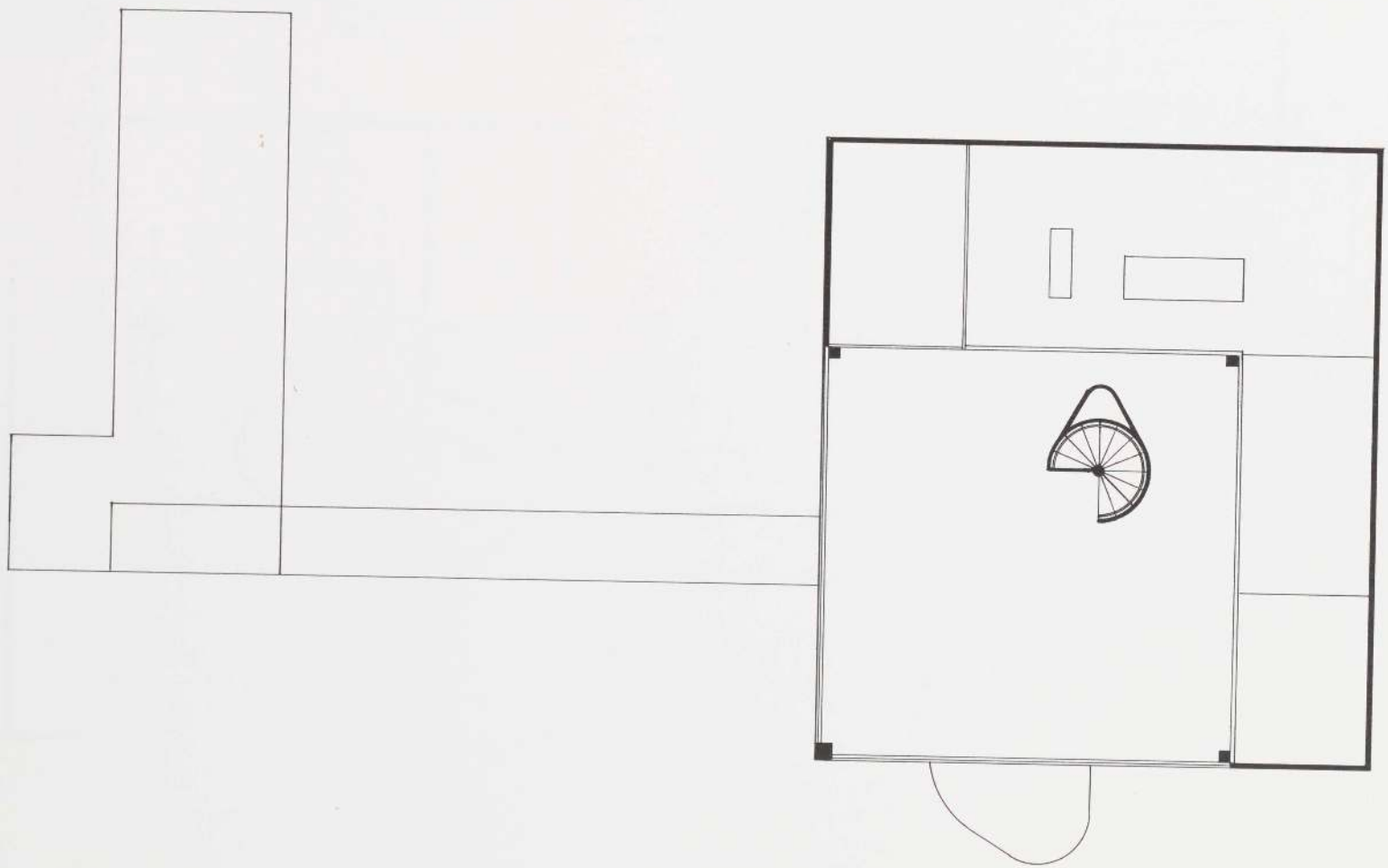

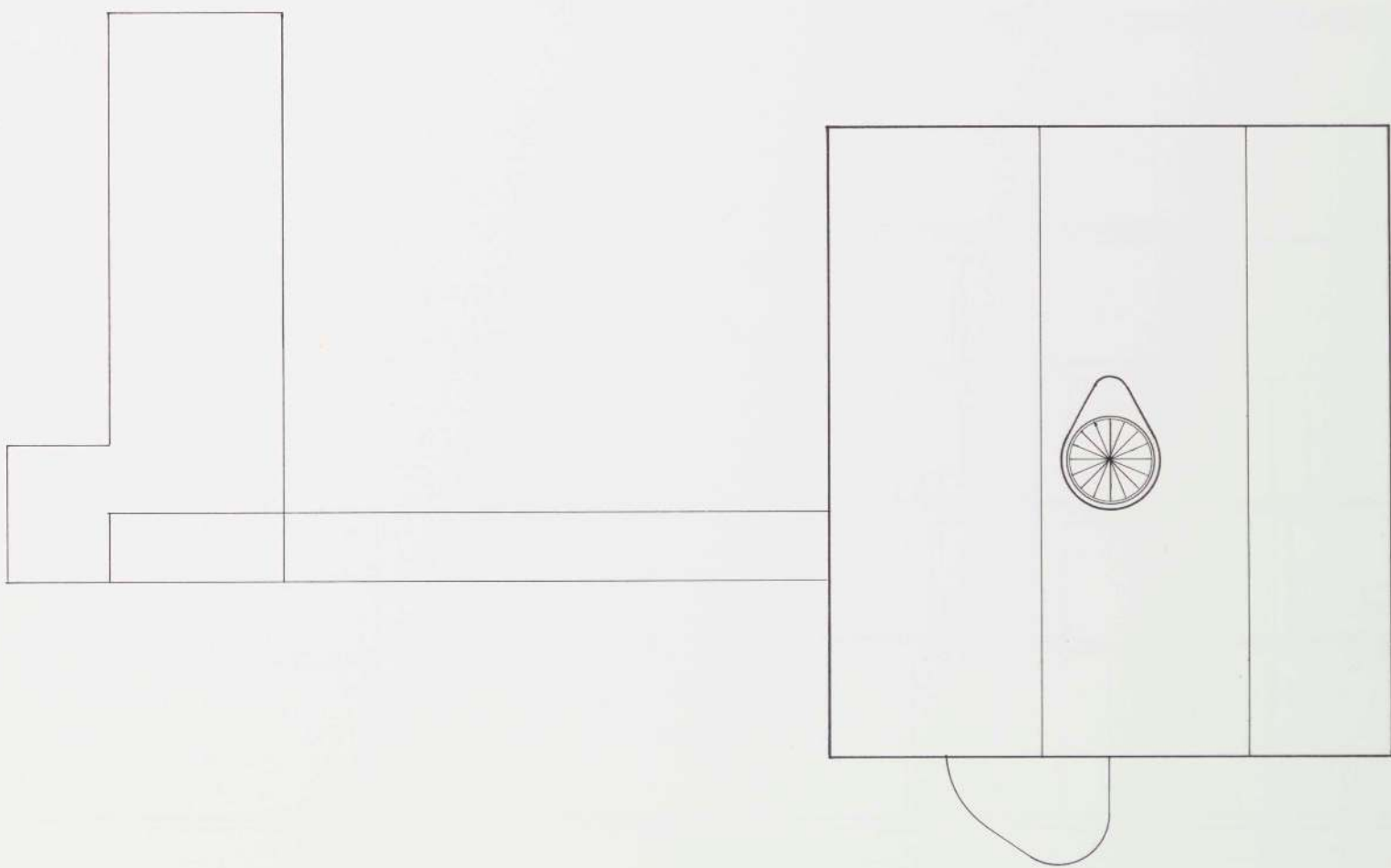

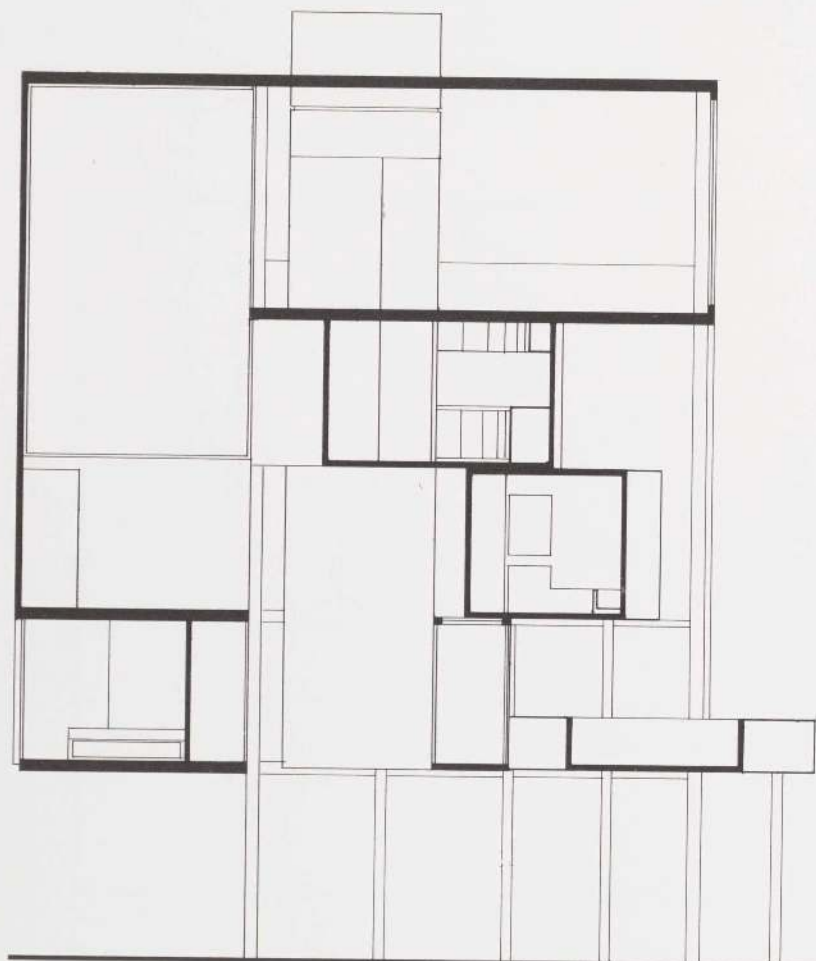



HOUSE/PAUL BONFILIO.

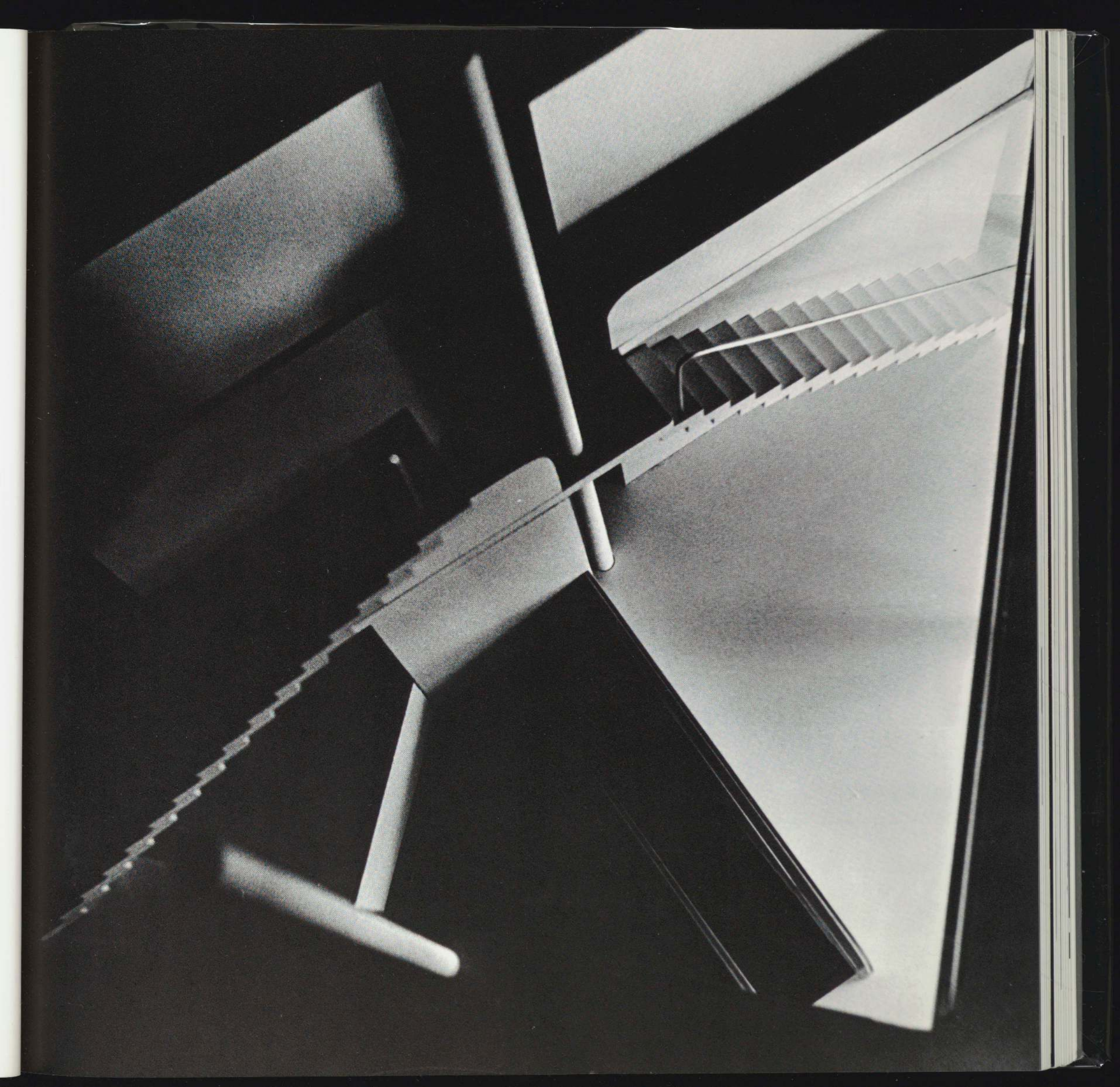

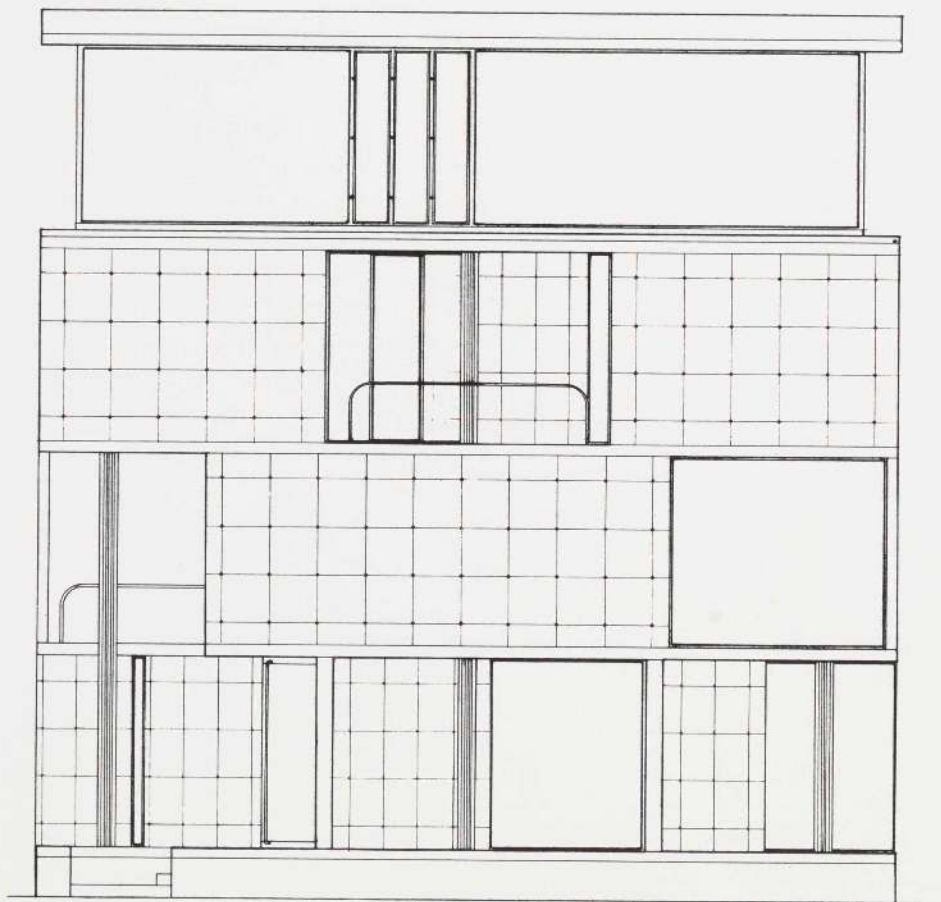
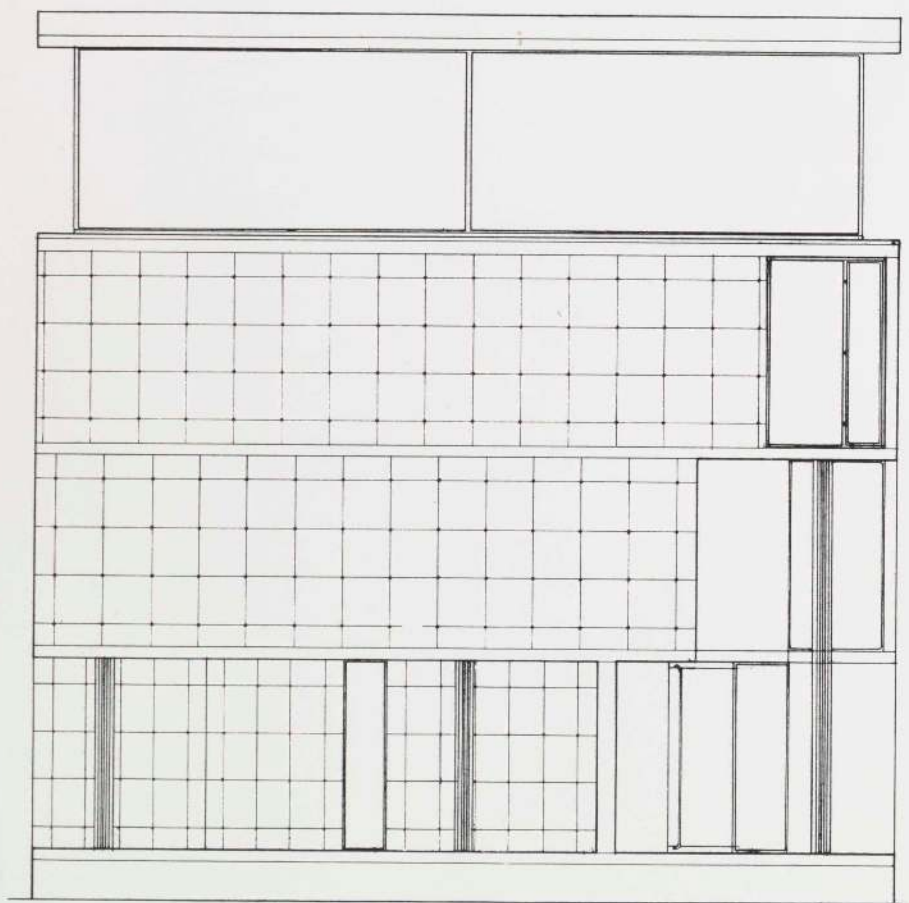

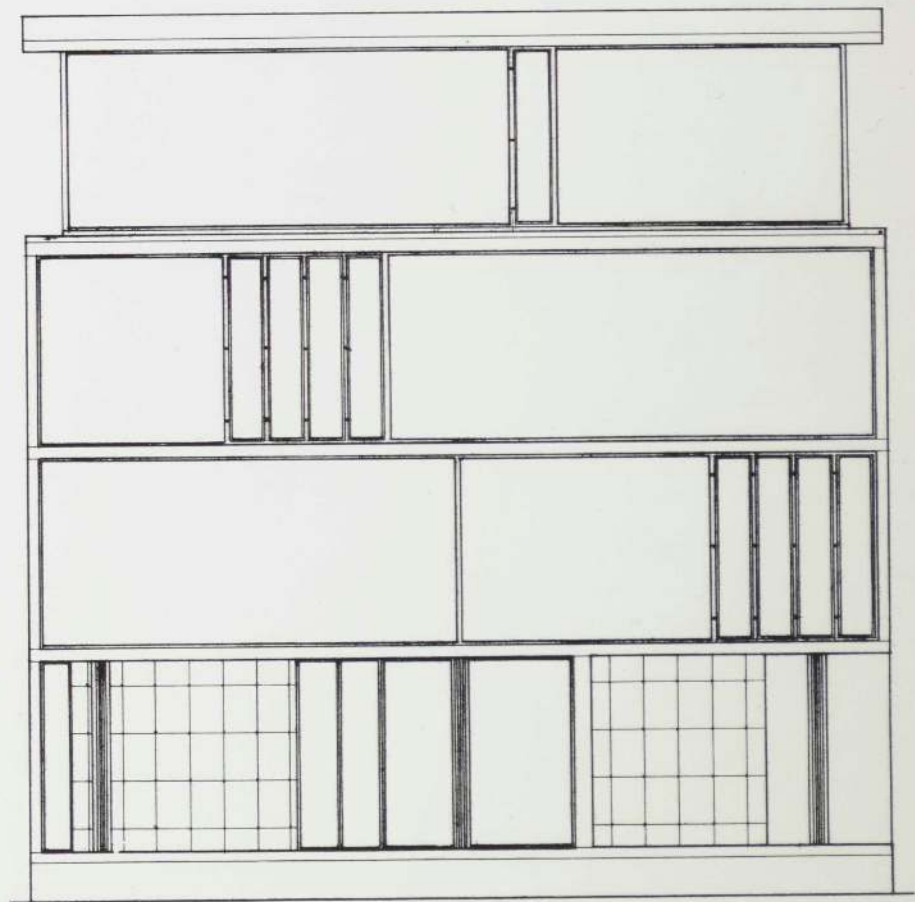
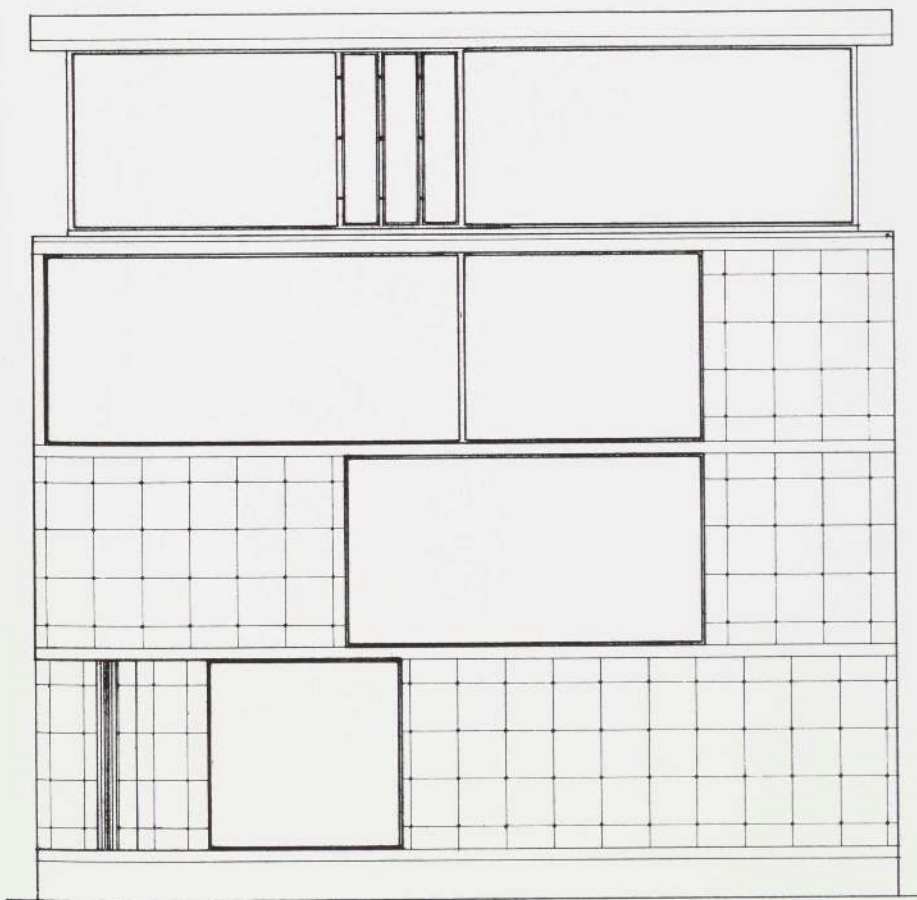

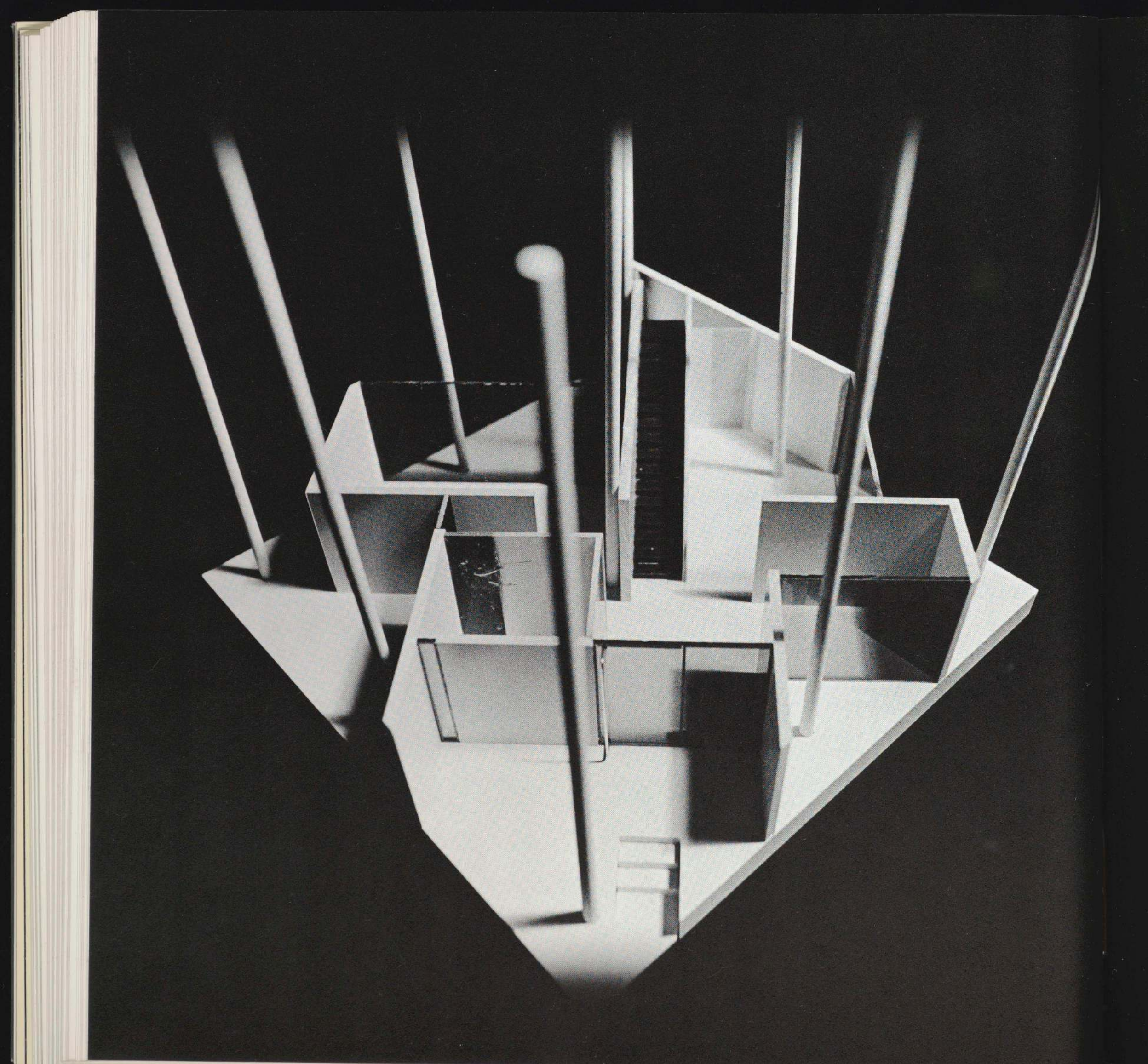

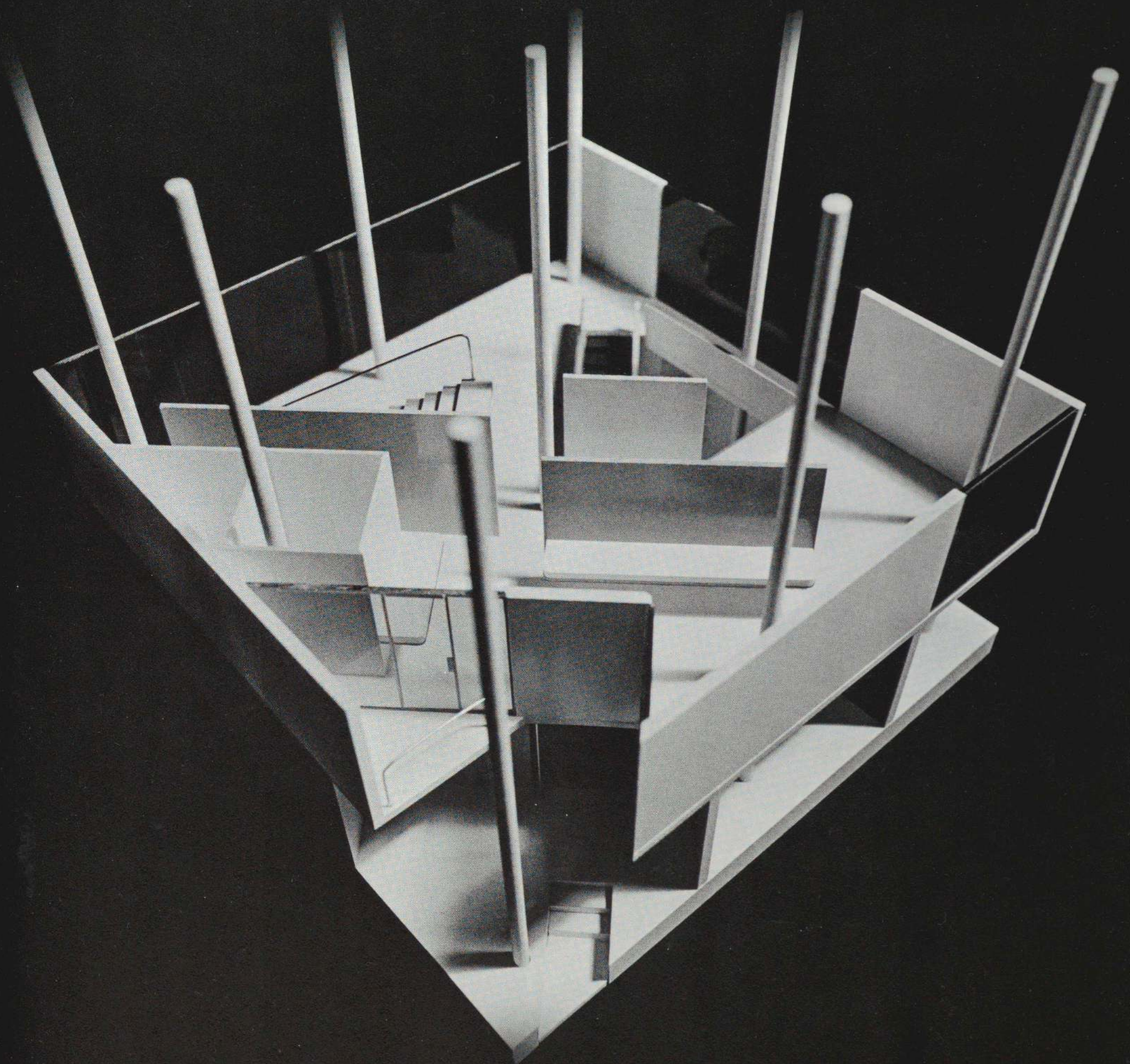

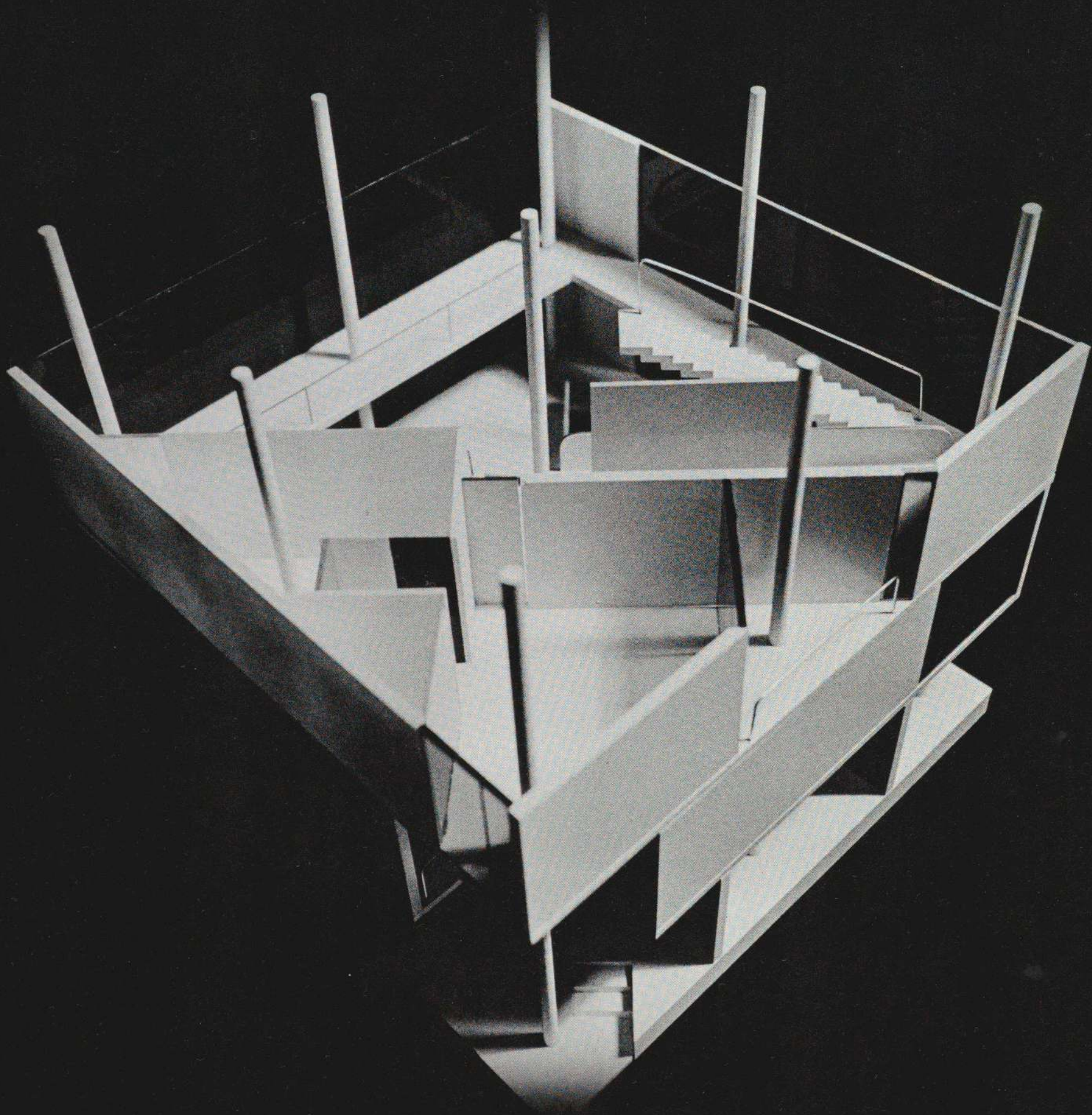

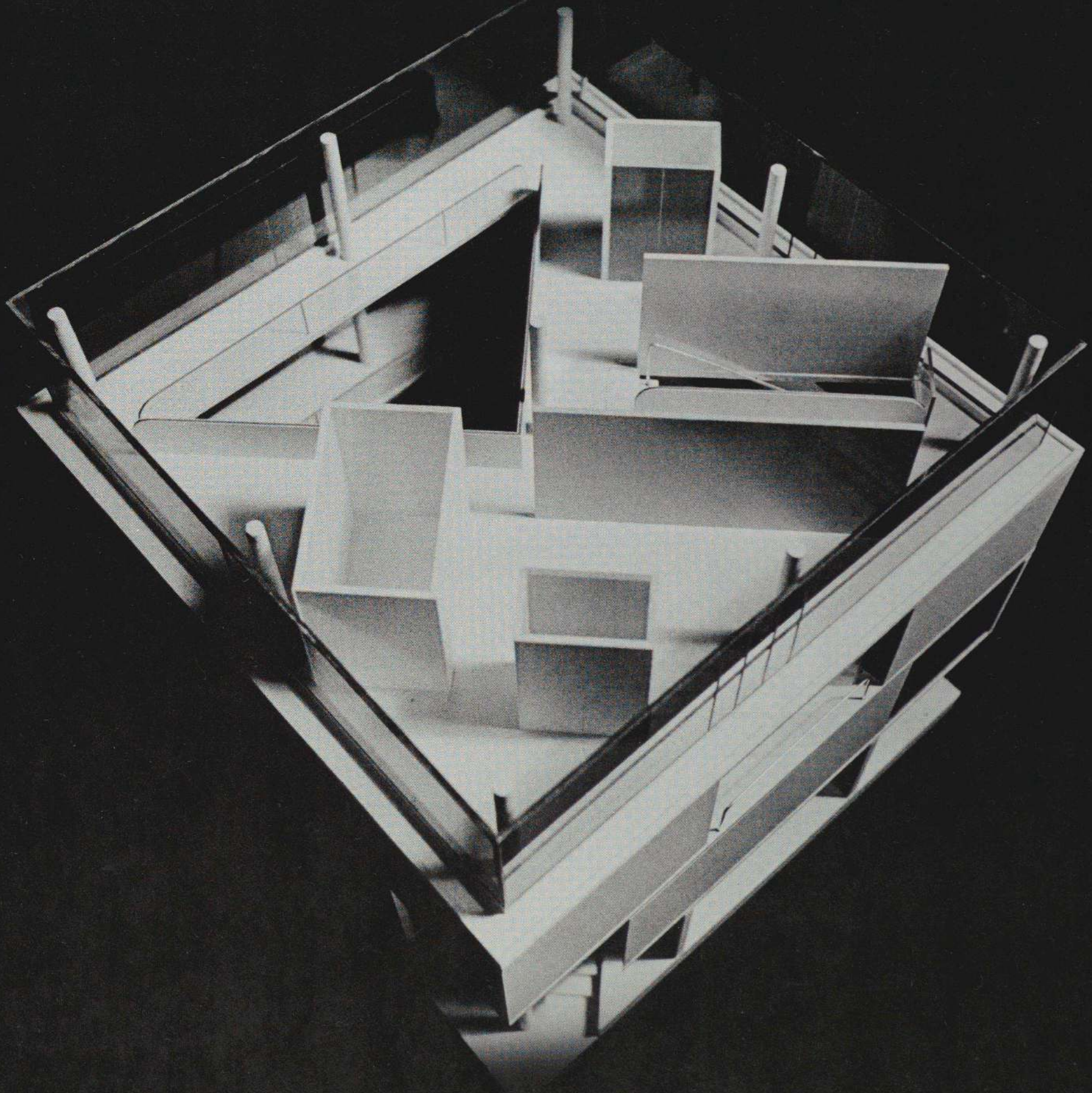

PLAYHOUSE/LAWRENCE PHILIP WITZLING. It was the intent of this design to provide a strict progression of spatial experiences in which: a) there would be a continually increasing contrast between the existing spatial experience of the observer and the next anticipated experience; b) this sequence would be appropriately culminated with a slide (the diagonal of a thirty-six foot cube) which would then place the observer back at the beginning of the spatial experience, and hopefully induce the feeling of having completed a 'geometric ordeal'; c) the repetition of this 'ordeal' would make more apparent the formal exploitation of the geometry of the thirty-six foot cube.

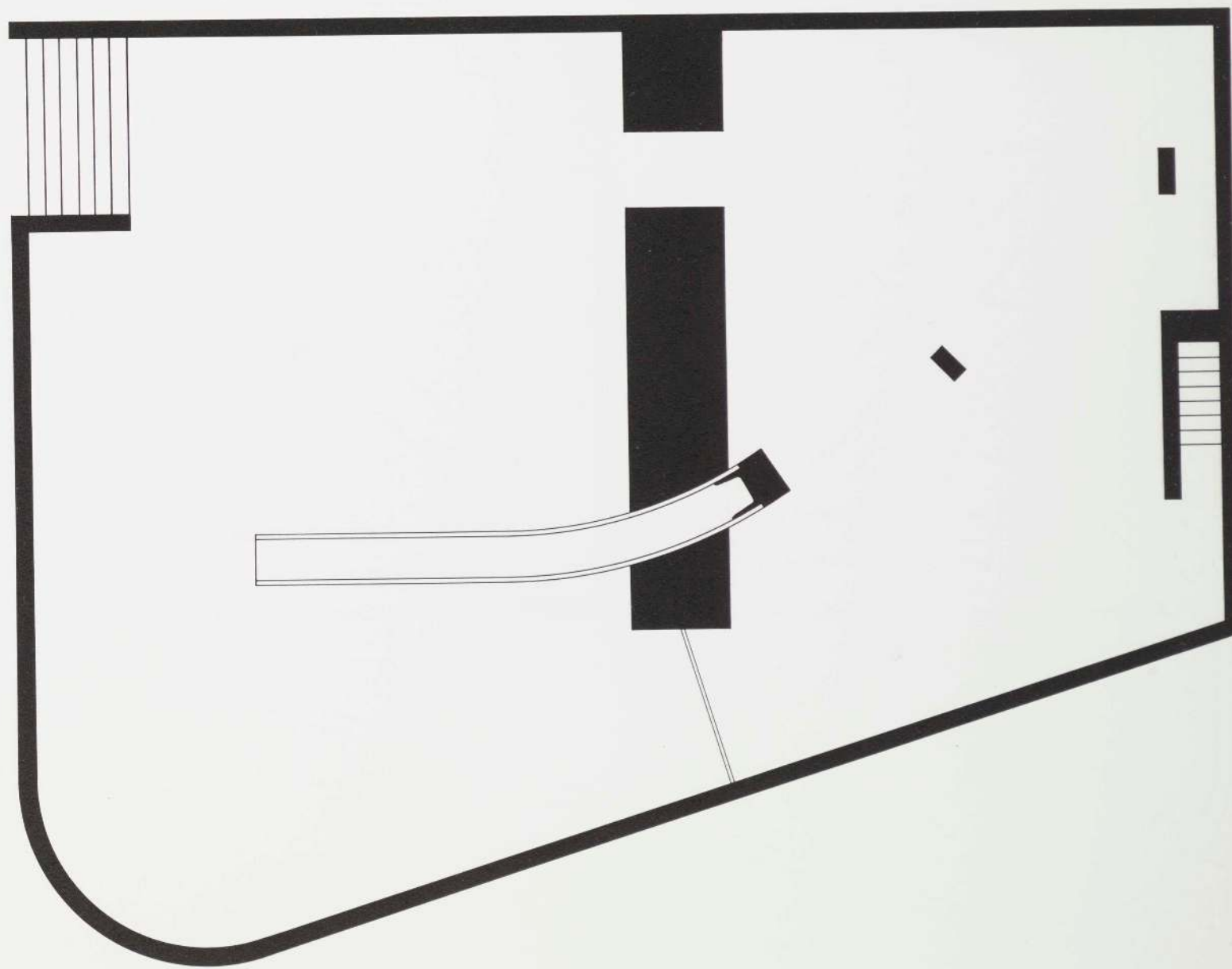

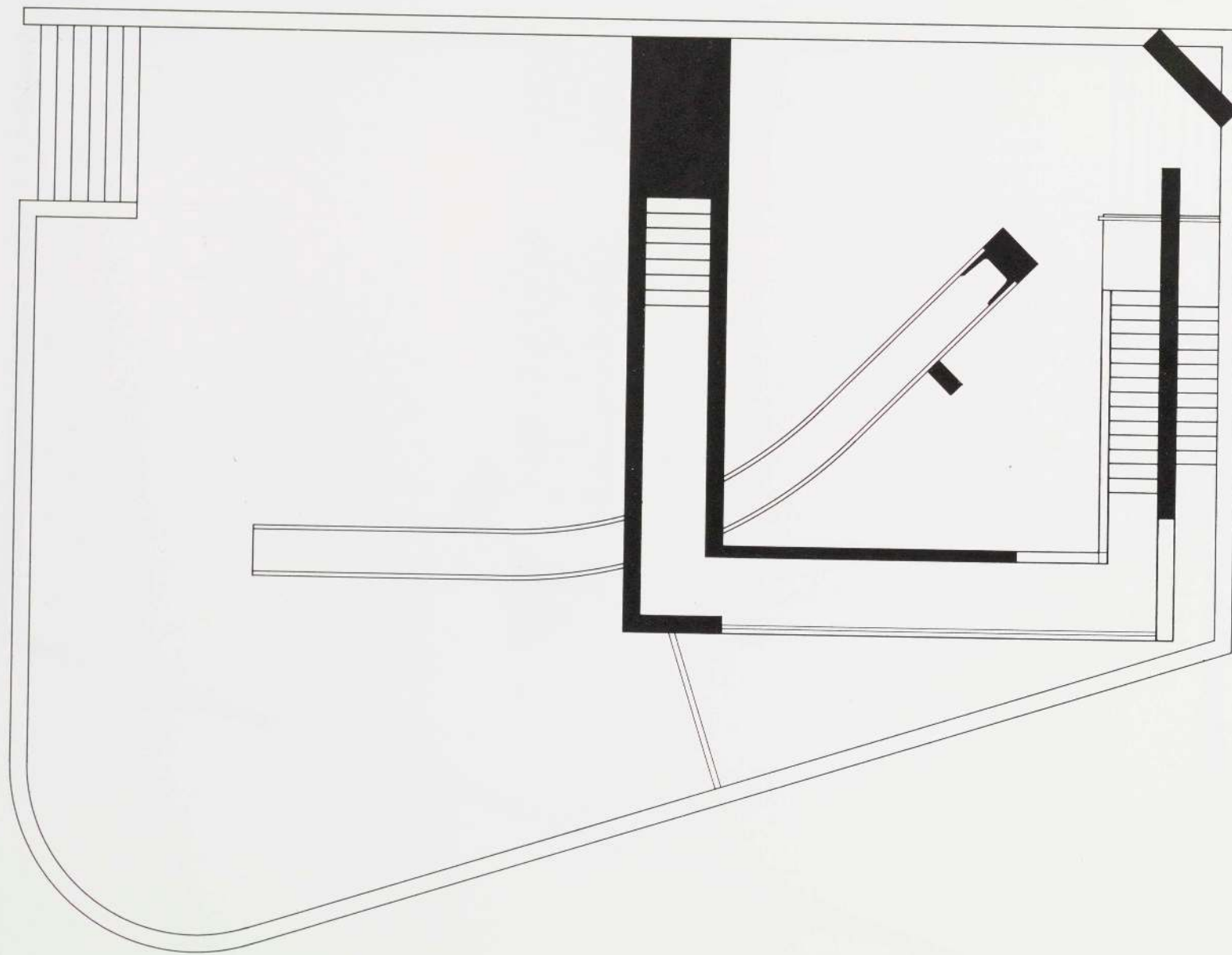

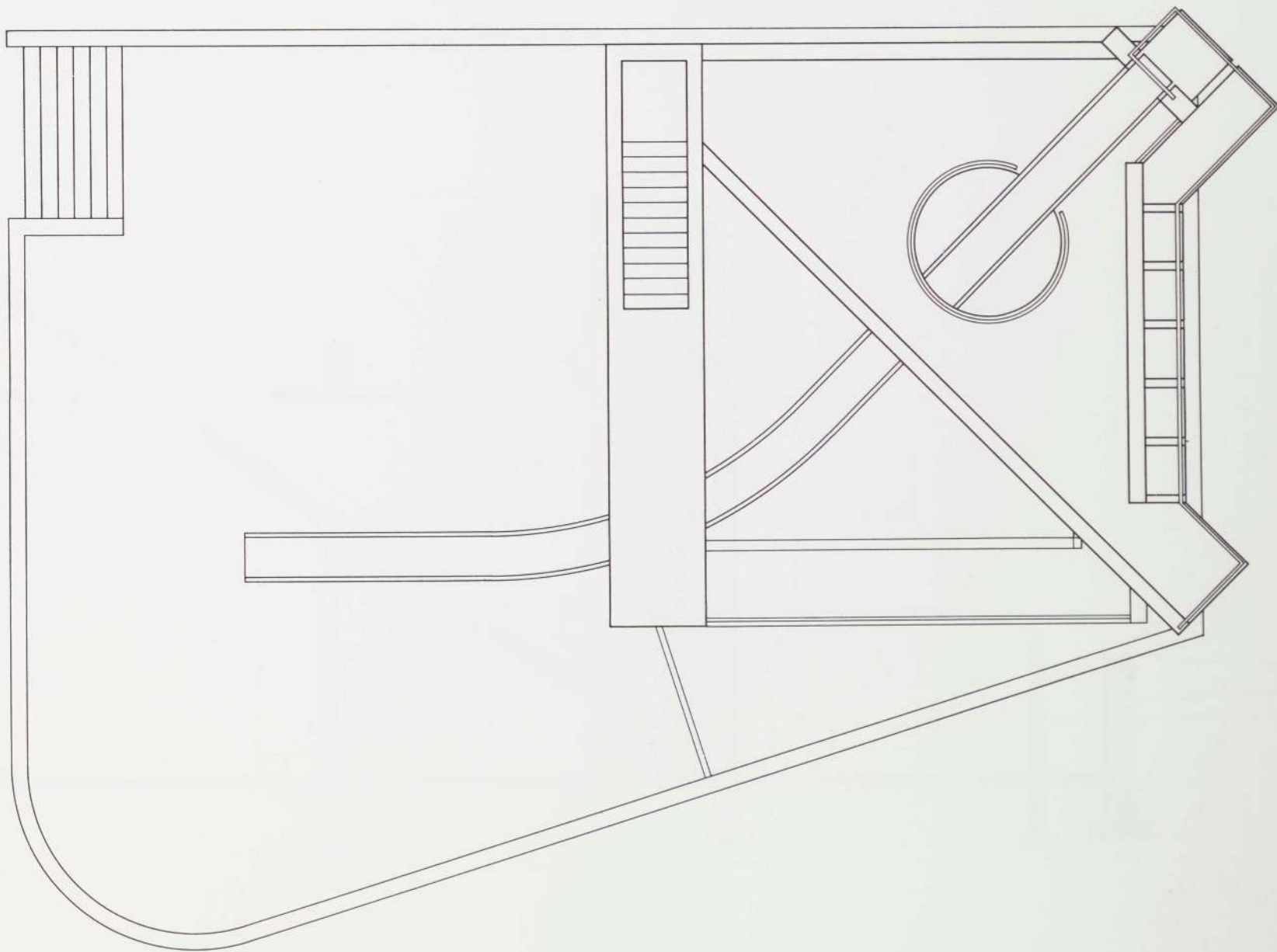

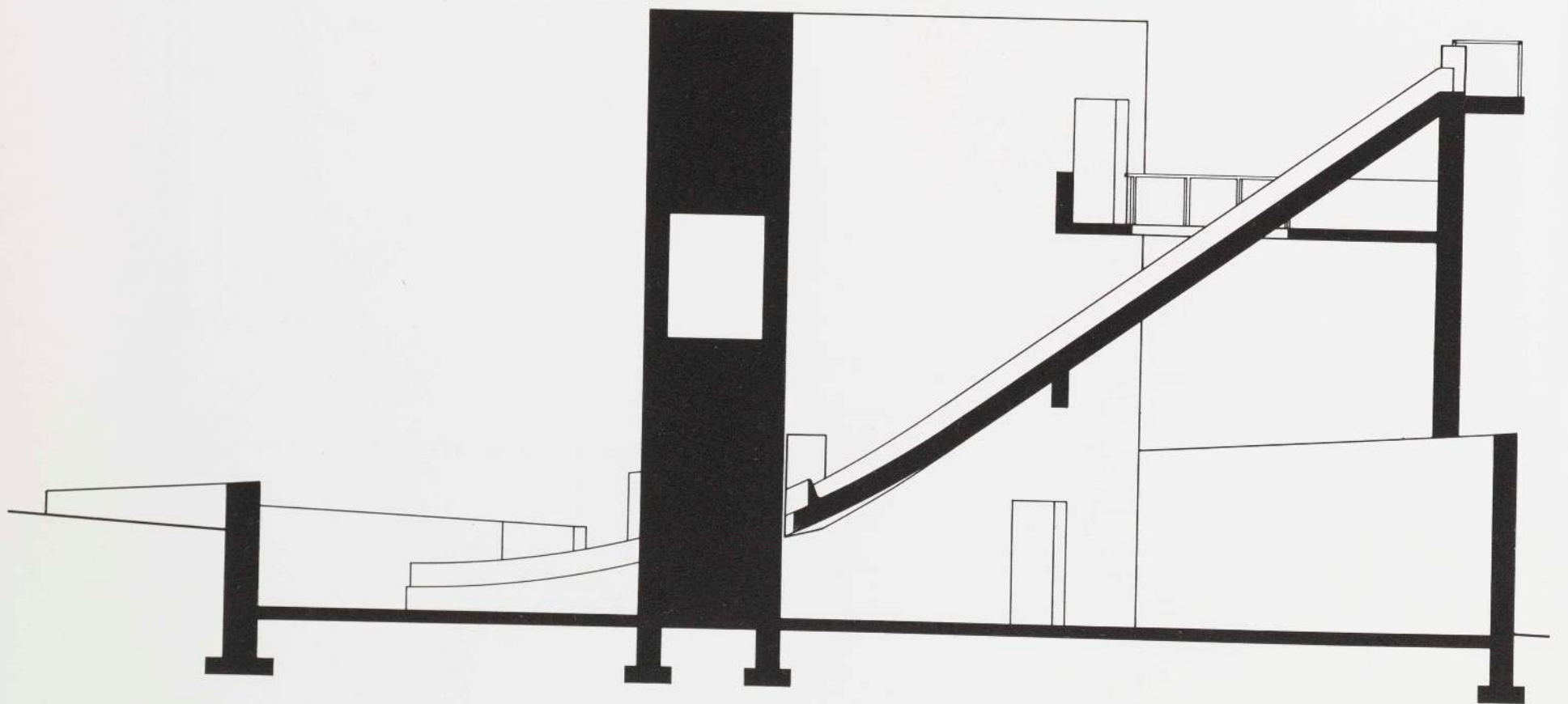

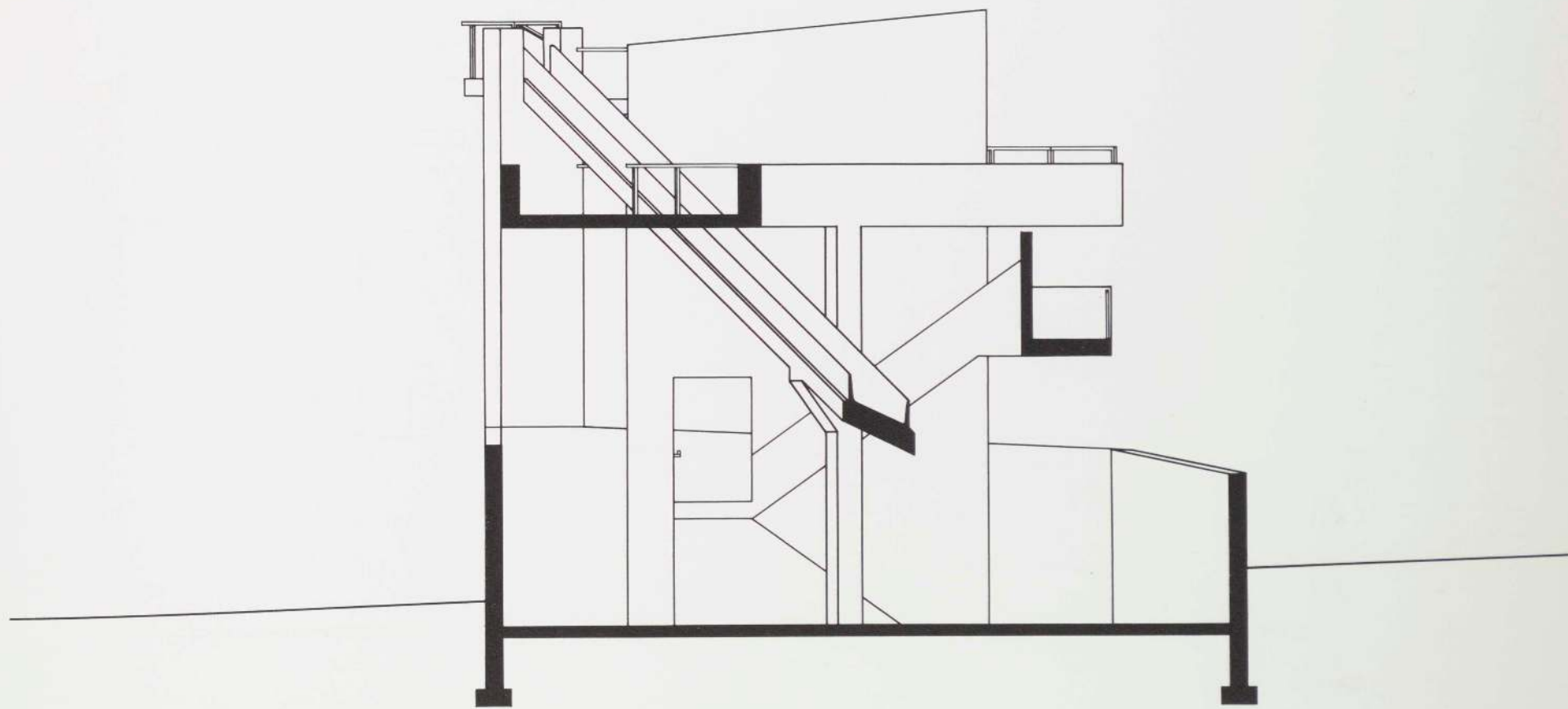

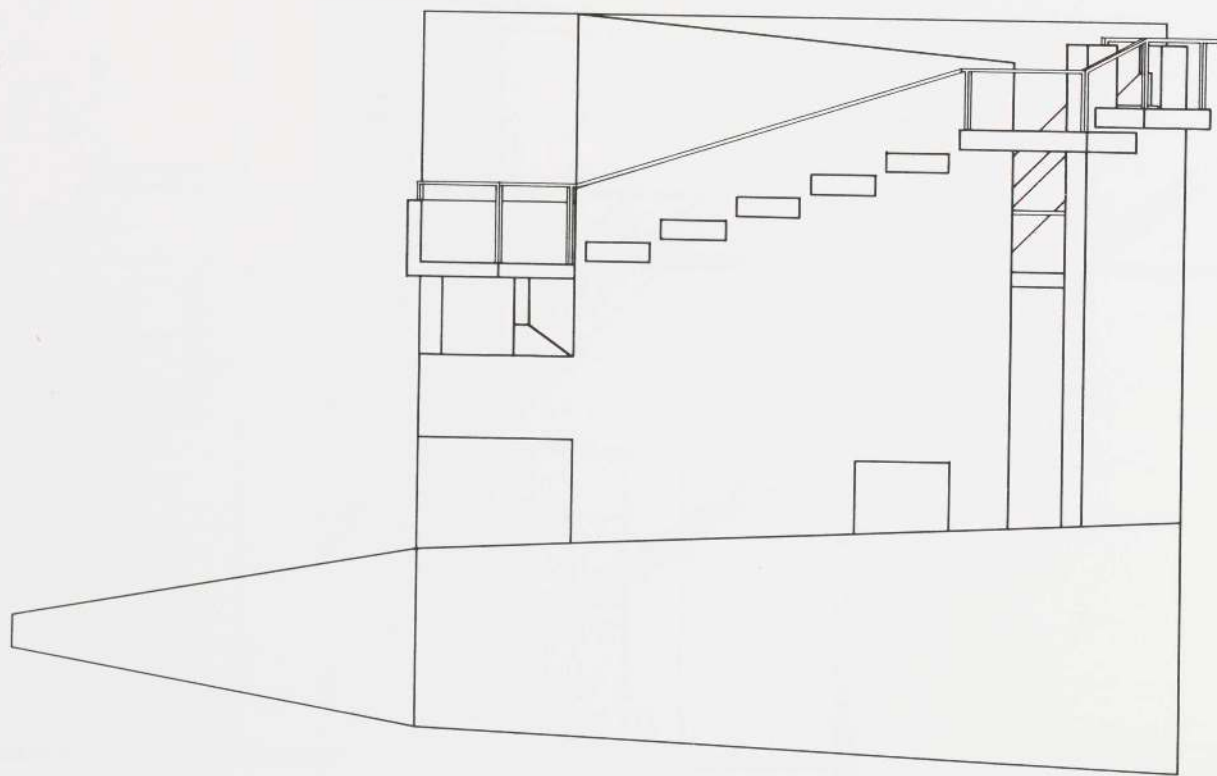

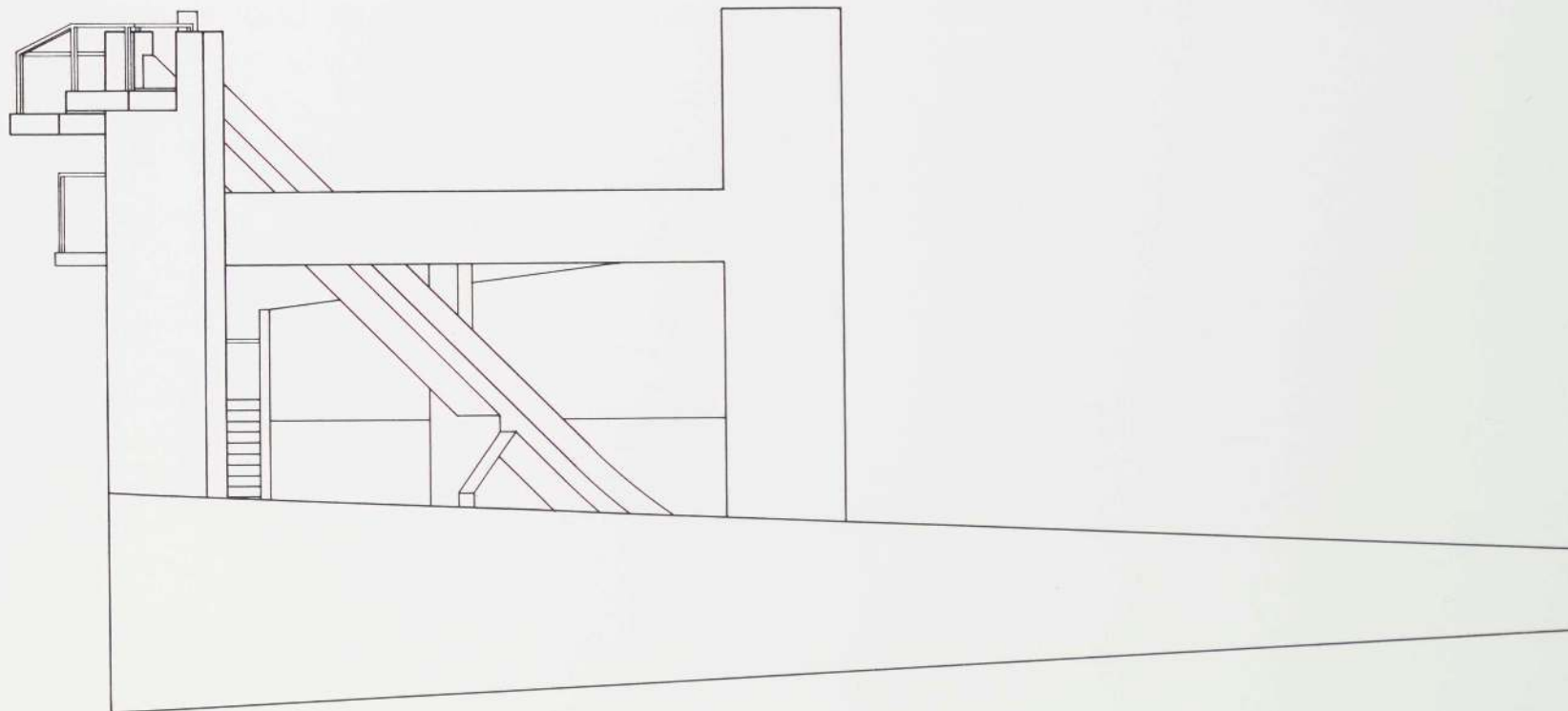

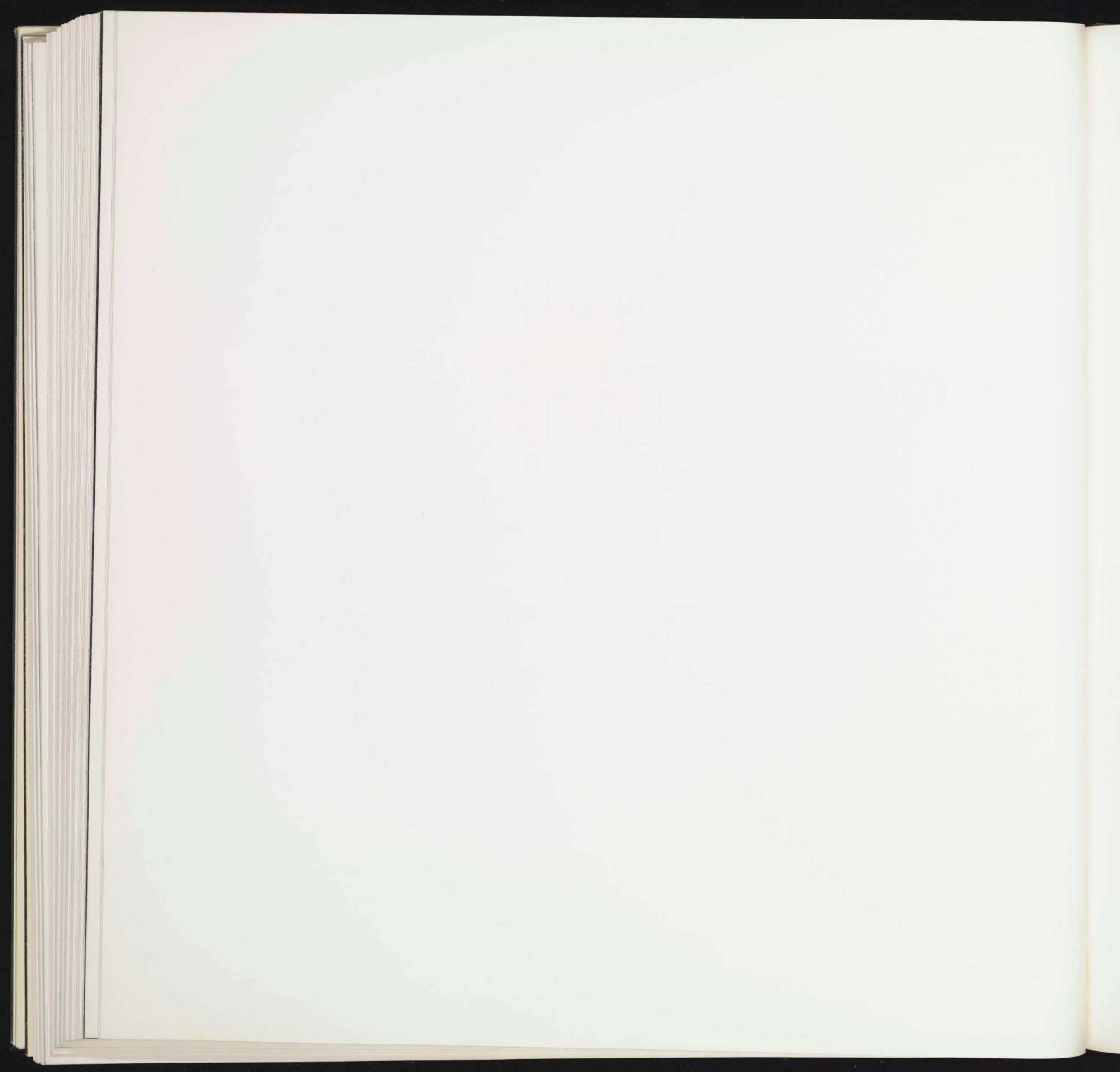

THE 'JUAN GRIS' PROBLEM. "Do a building in the intention of Juan Gris." The 'Juan Gris' problem is simply stated as in that quote—no more—no less. A project evolves or it does not evolve. The problem as given has provoked strong reactions, pro and con, within the student body and faculty. There are articulate arguments against giving such a problem. There are deep reservations about using 'Juan Gris' in such a manner. The problem is perhaps one of the most difficult ones to present. Most students reject it outright—some become interested in its implications. A few, using it as a foundation for movement, produce a work. For those who do choose this problem, a very thorough analysis into the generating ideas within the paintings of Juan Gris and within the work of the Cubists—Picasso, Braque, and Leger—is made. Relationships between the ideas and work of architects and painters are discovered. An understanding of the organic links is revealed. The pursuit is more than just an historical analysis—for the student produces a work. He finds that the initial statement of the problem launches him into the world of re-creation and finally creation. This, of course, could be the illusionary view of the teacher—the student's reality may be elsewhere. The above does depend on the belief that 'Juan Gris' is important to architects and to the issues of today.

John Hejduk

AN URBAN RESIDENCE/LEWIS GARY COOPER. Too many architects and students recently seem to have become overwhelmed by a preoccupation with the so-called 'relevant' problems of environmental change—the immediate social, economic and political impacts of architectural practice—while neglecting architecture's potential as a traditional fine art to give intellectual and sensual satisfaction through the visual impact of elegantly shaped and ordered form. Too many seem to forget the role in modern architecture of plastic experimentation, the need for a continuous search for new forms and new means of organization expressive of the age, and architecture's natural kinship with the pure arts of painting and sculpture through the sharing of common principles and philosophical objectives. Yet our growing environmental awareness and changing needs suggest new possibilities for formal and spatial investigation. The complexity of modern society makes possible, and perhaps imperative, a new level of simplicity in architectural thought, a deeper conception of the spiritual and theoretical natures of architectural and urban design, and an enhanced appreciation of the varied cultural materials at hand from which new personal approaches may be composed. It thus seemed possible that an interesting thesis program could be evolved from a formal investigation of some aspect of space in modern architecture. One essential theme in the history of modern architecture called to my attention, which seemed at the time to demand further intuitive study, was that of the contrast between static and dynamic elements and corresponding states of organization, and the associated parallel development of the relativistic theory of measure, which upset the static classical order of absolute measure. The history of modern painting shows us how this new order of space and measure became embedded in the arts through the revolution of Cubism. Professor John Hejduk's suggestion that a contemporary expression could be attained in a building designed according to the principles of Cubist painting as they were interpreted by Juan Gris opened a basis for speculation on the relevancy of systems of measure to the design of the real environments. A few experiments in spatial logic and surface organization quickly proved the plausibility of a program based on the recognition of these concepts as a logic applied to the organization of actual living spaces, and thus determined my course for the rest of the year. I then proposed for my thesis a set of program objectives. The essential dialectics of static and dynamic space and absolute and relative measure suggested a corresponding logical programmatic division of residential spatial components into those which would naturally require formal, regular arrangement in an efficient functional hierarchy and those which should form a generalized place for entertaining and casual relaxation, inherently flexible, open, undivided space through which people could freely circulate and would be encouraged to circulate by dynamic spatial configuration. The problem of over-all organization then became one of meshing into a unified, organic composition two unique, contrary, and perhaps incompatible spatial elements. A third functional system of spaces providing horizontal and vertical transportation and communication was developed to link and separate the principal parts of the composition. A more persistent structuring agent was also suggested by the potential visual continuity that could be achieved through a system of layers of parallel planes of different degrees of transparency, through which the linking axis of the apartment unit passes. It was also my intention to solve the problem in an urban context. The contemporary city and its way of life present the most urgent challenge to current architecture. A significant form must be found to express the positive aspects of city life. Thus the typical city site must be considered an asset rather than a liability. The building must admit the logic of the site, and must add to the ultimate quality of the environment. The final solution is, I admit, a rather luxurious kind of apartment block. It is not my intention here to advocate my

pragmatic solution to the present national housing crisis, but only to hint of what is logical and reasonable within our present urban structure. The plan itself is divided into a series of parallel functional layers which progress from static activity rooms (dining and bedrooms) to a service group of kitchen, breakfast, storage, dressing and bathrooms, to an inner courtyard, and finally to the diagonal element reserved for informal living activities. The site is a slot through a typical midtown Manhattan grid-iron block, 195 feet deep between the building lines. As the site is essentially prototypical, further details about the surrounding environment are a matter of speculation. A subsurface garage level with access ramps to both adjoining streets has been added. The ground floor level contains a utility room for each apartment, along with a system of lobbies and corridors to provide convenient passage between the apartments, elevator core and stair, outdoor gardens, access paths, and streets.

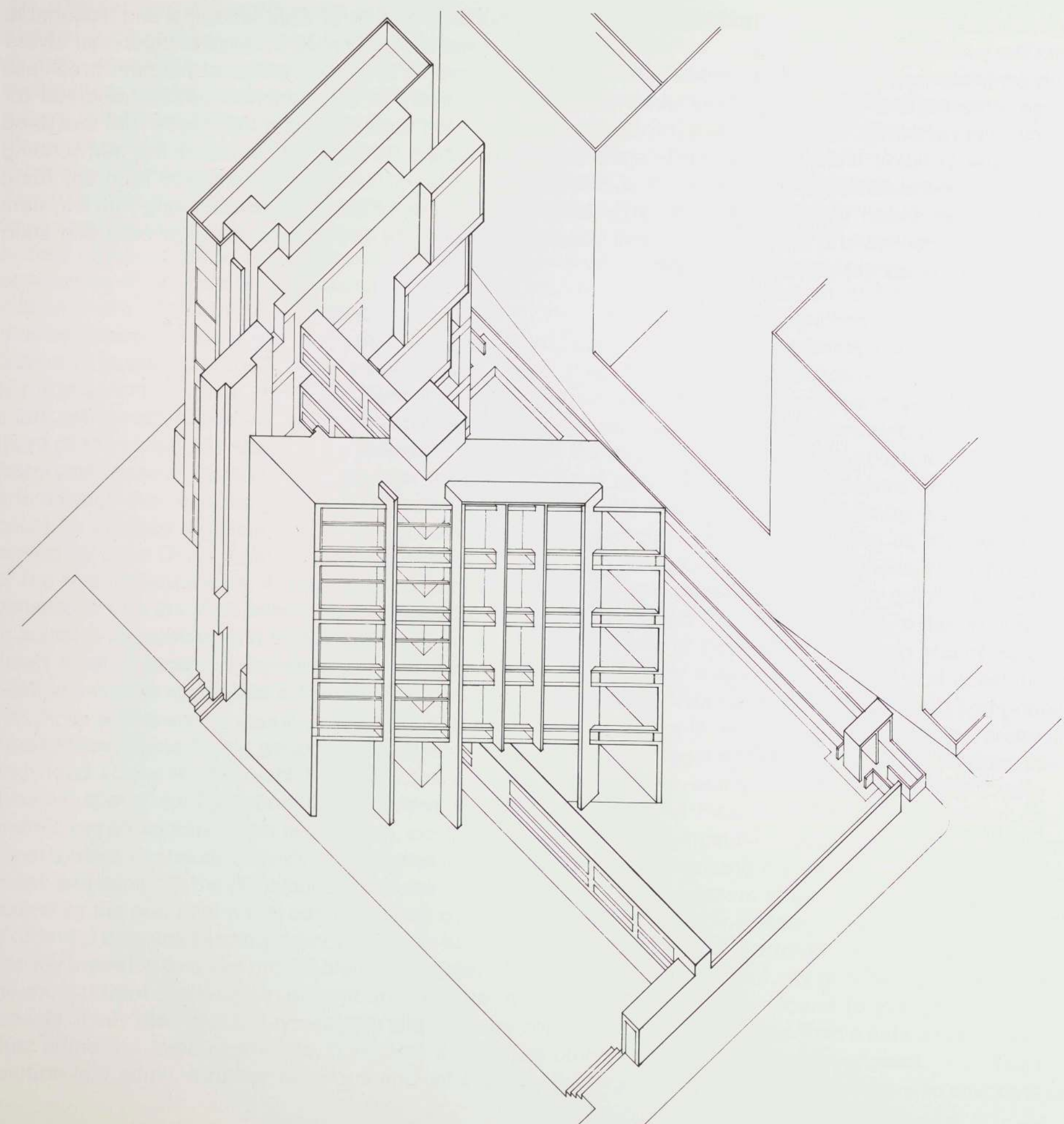

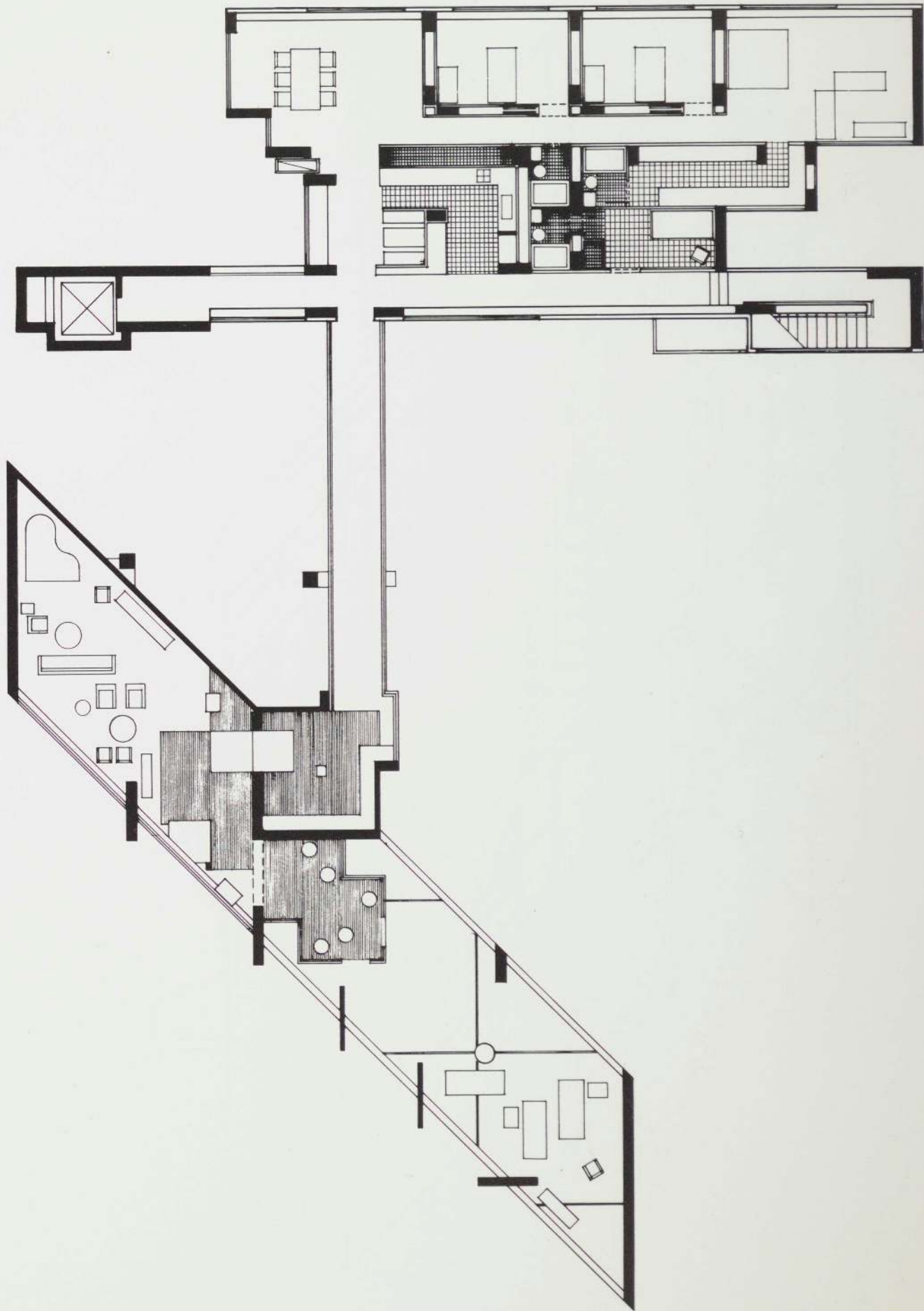

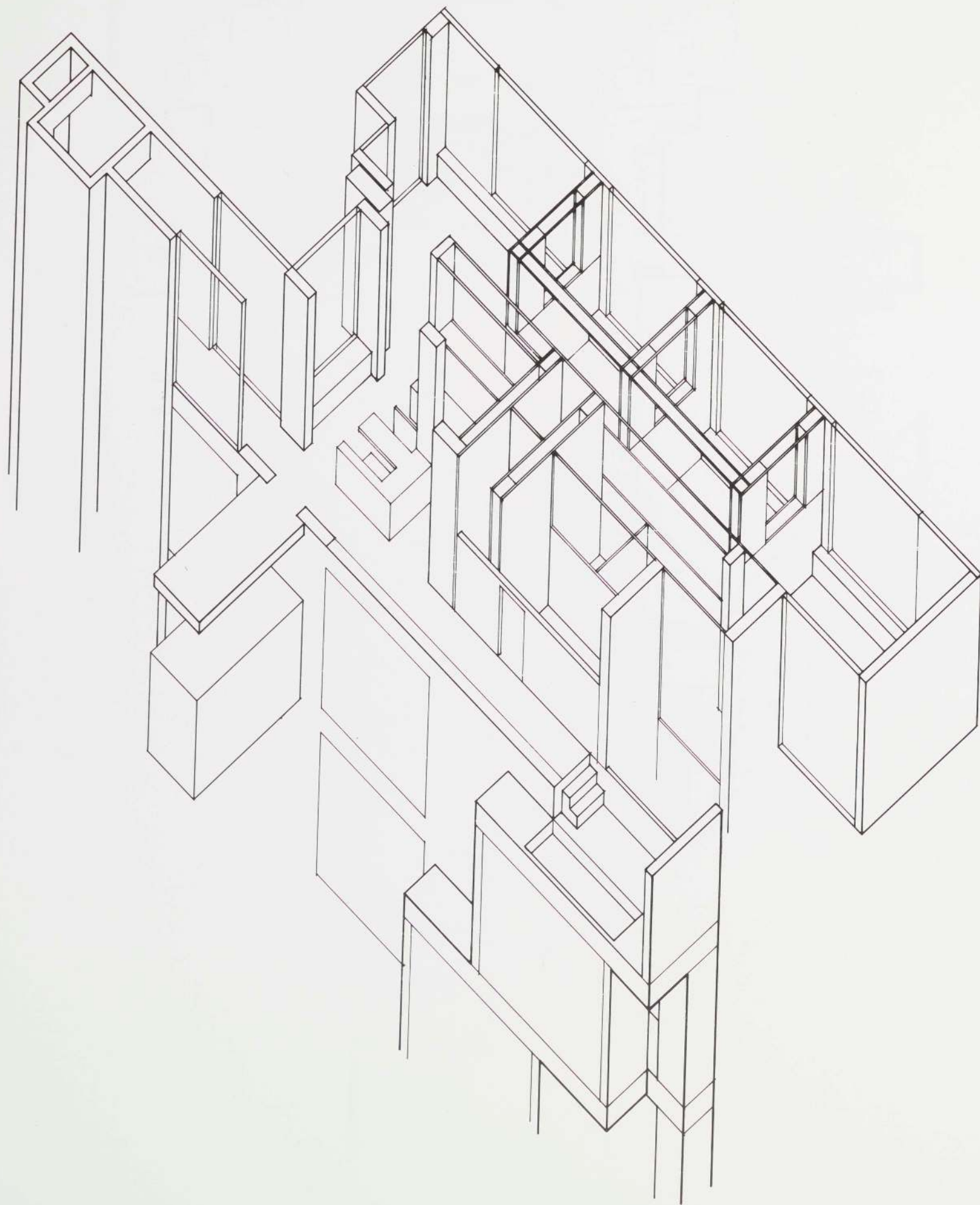

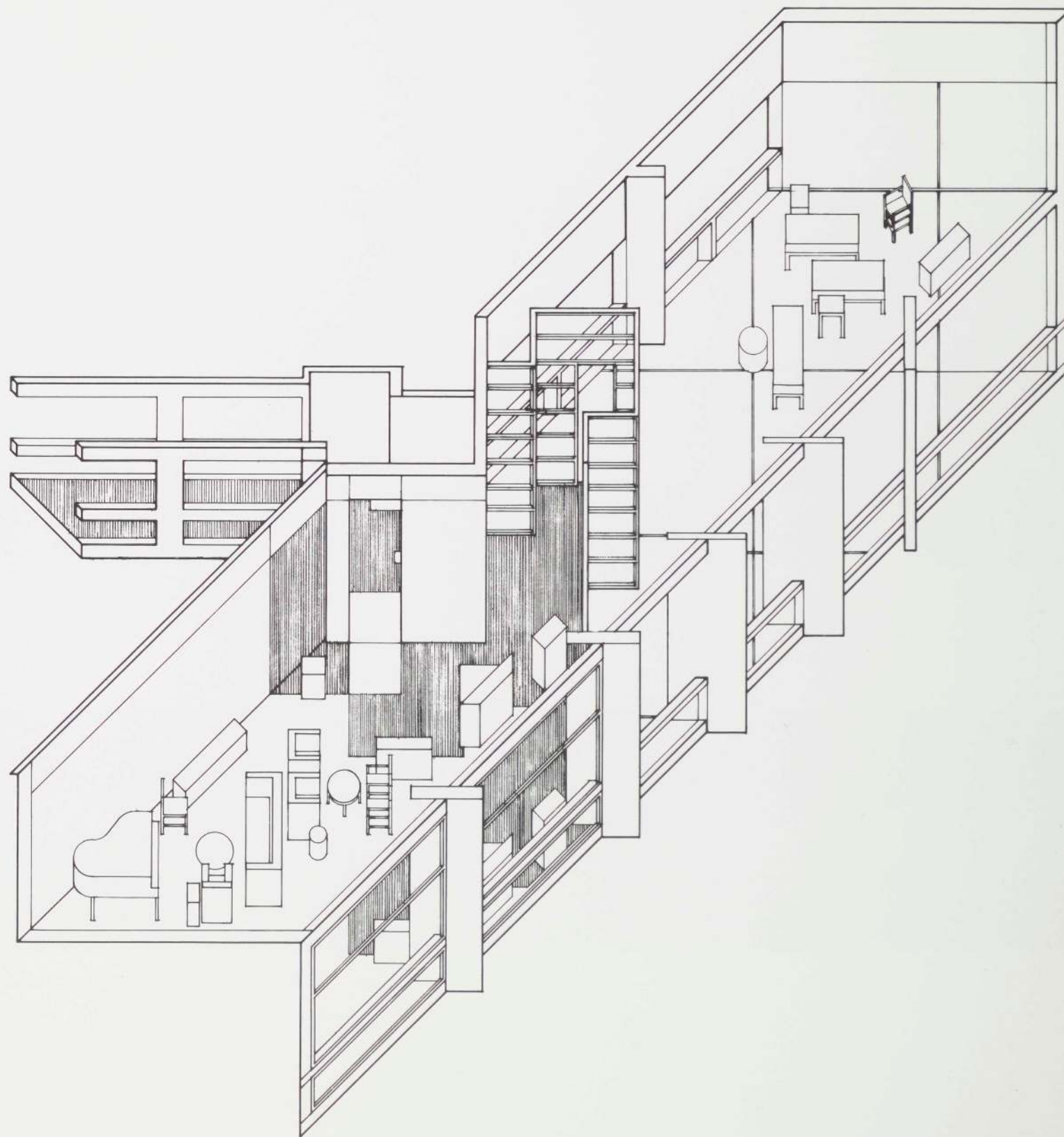

HOUSE/PAUL AMATUZZO.

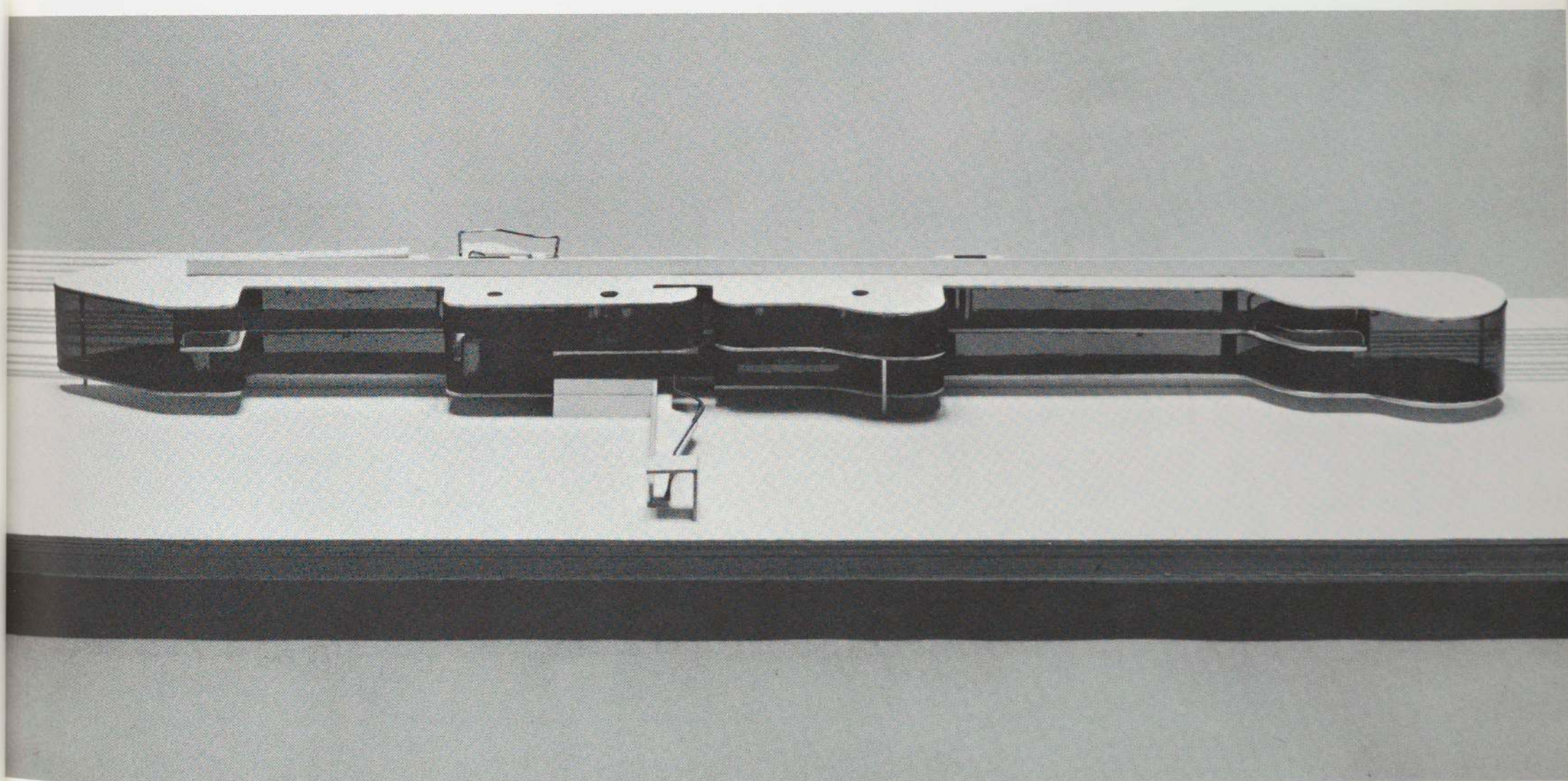

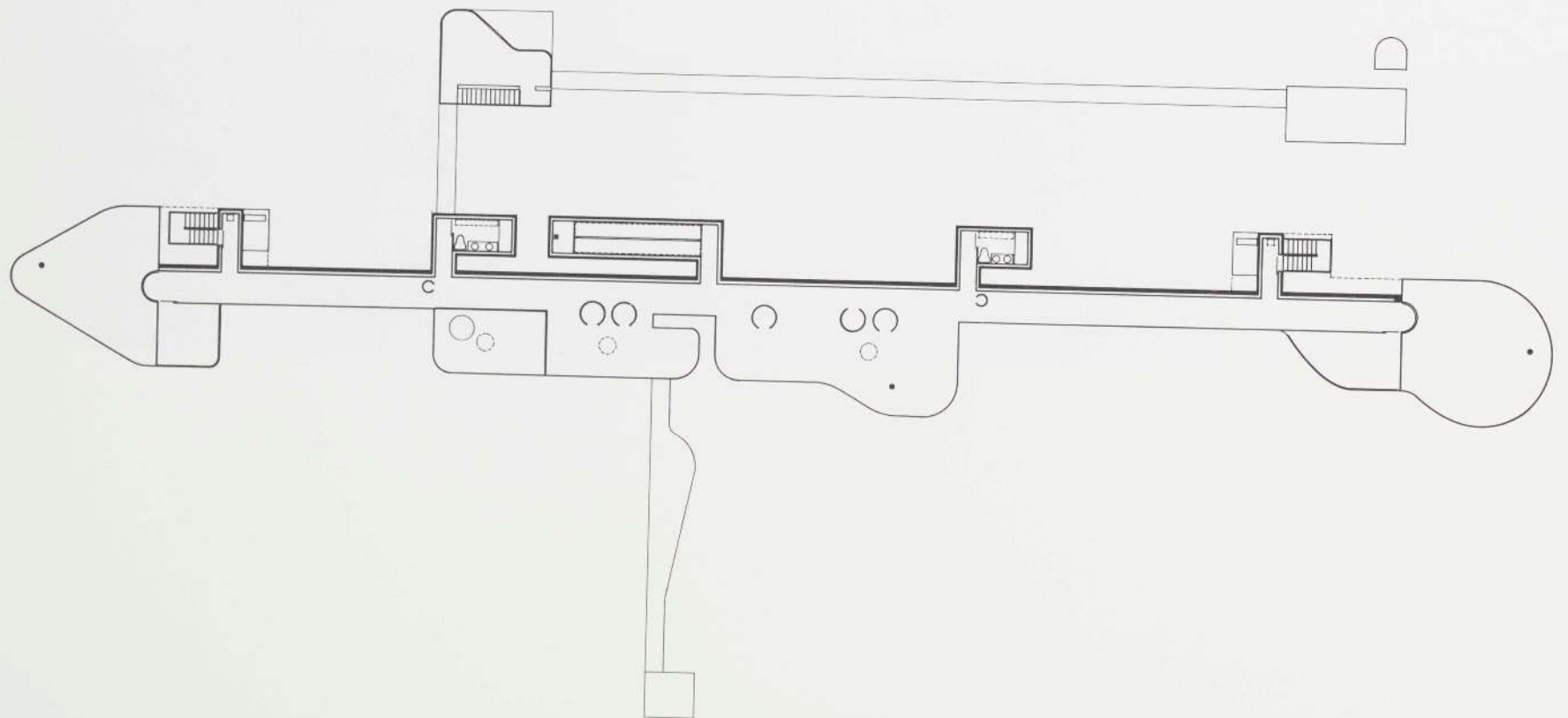
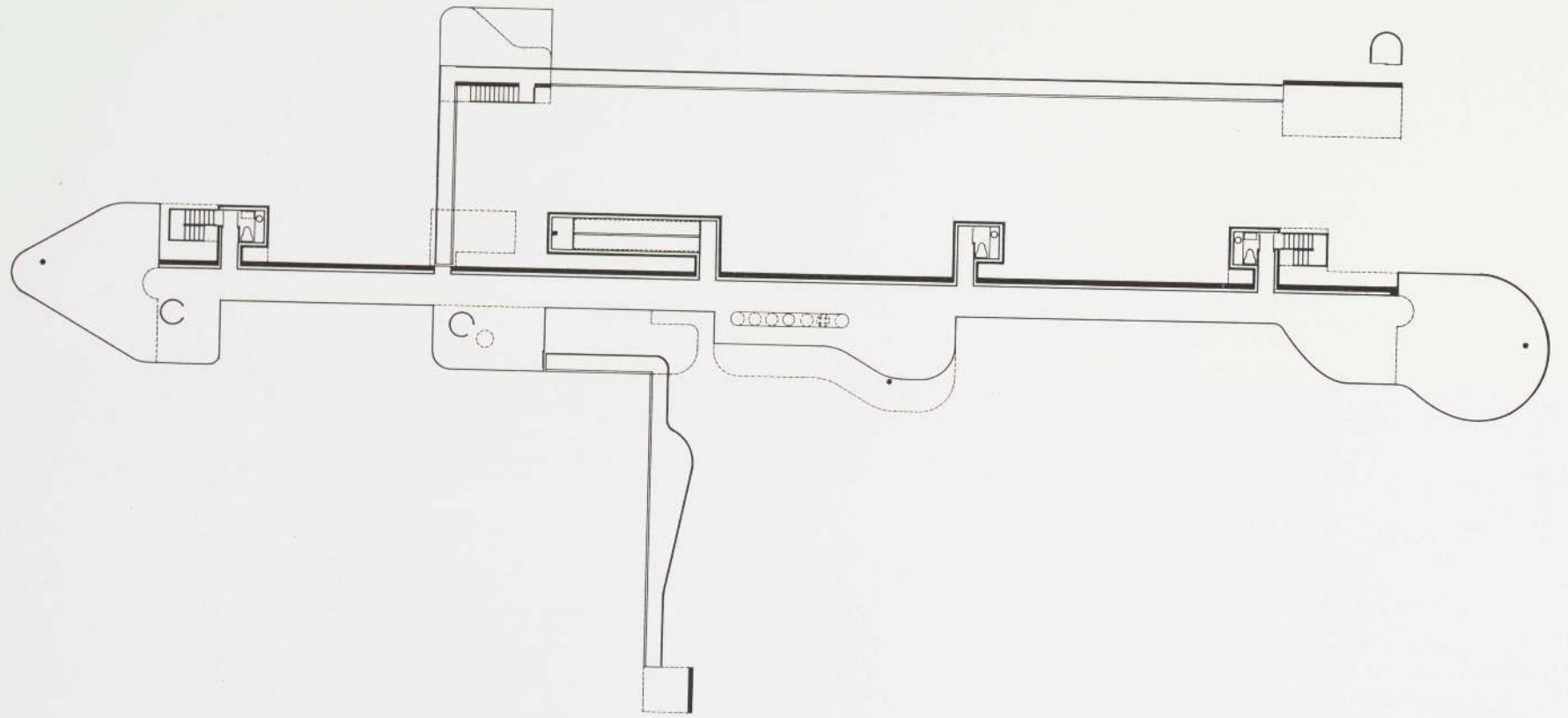

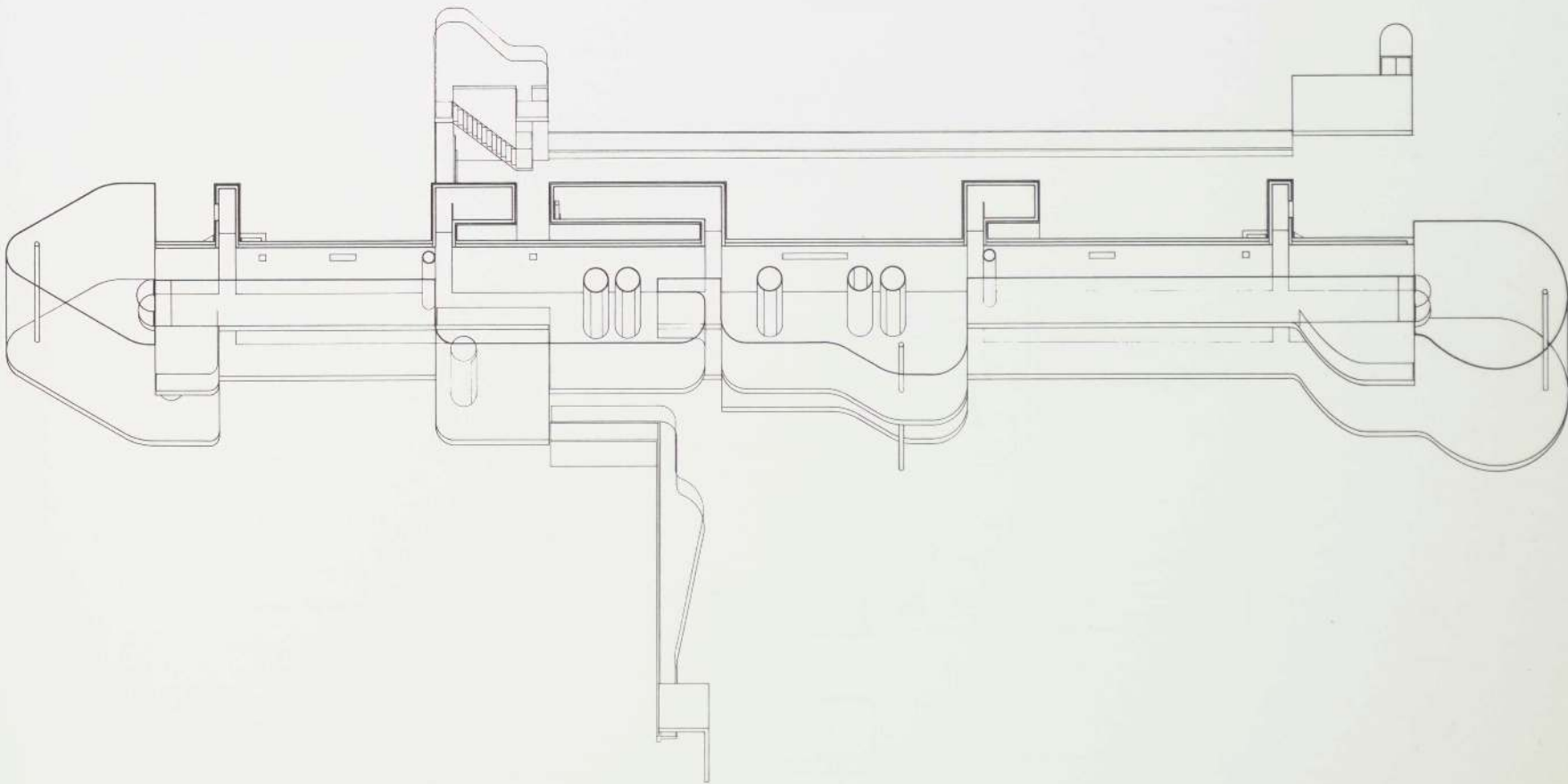
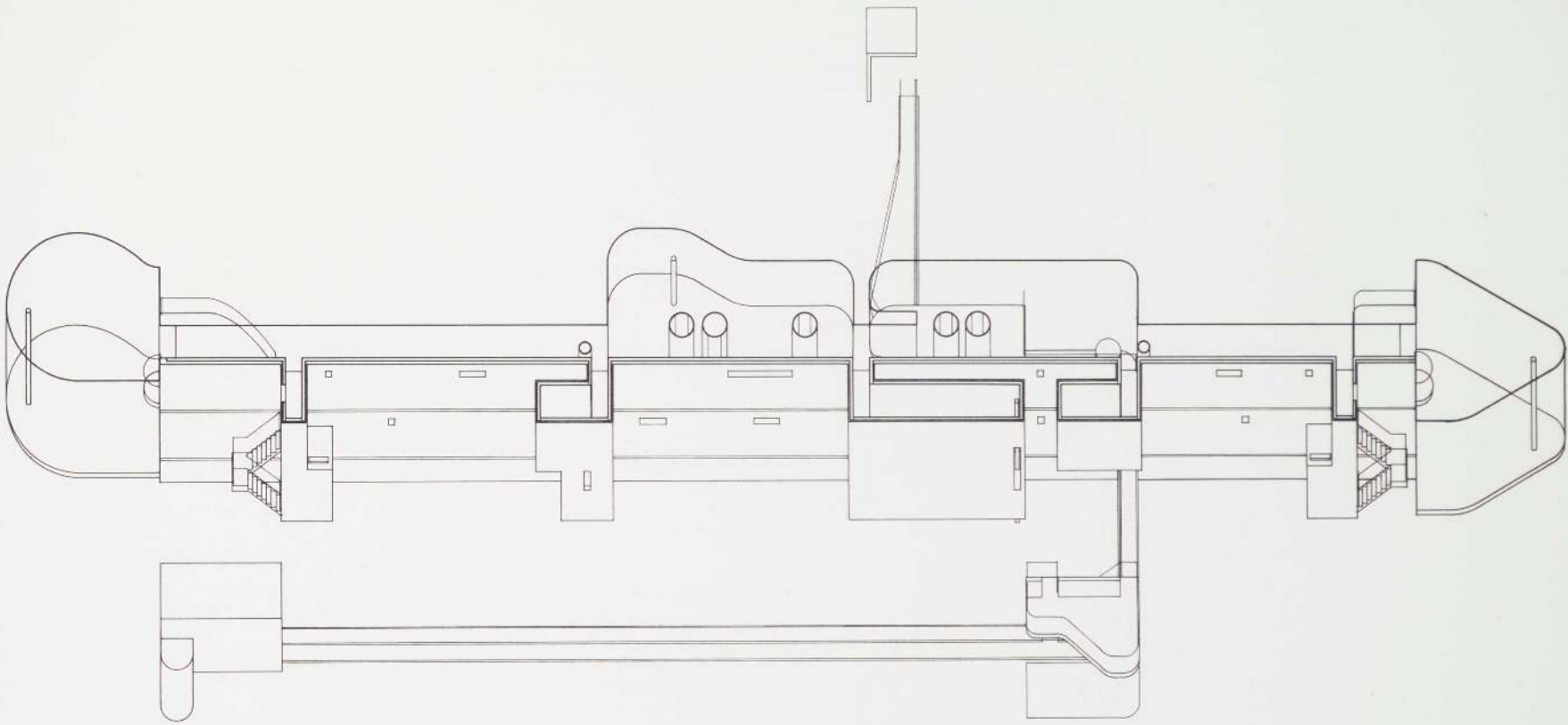

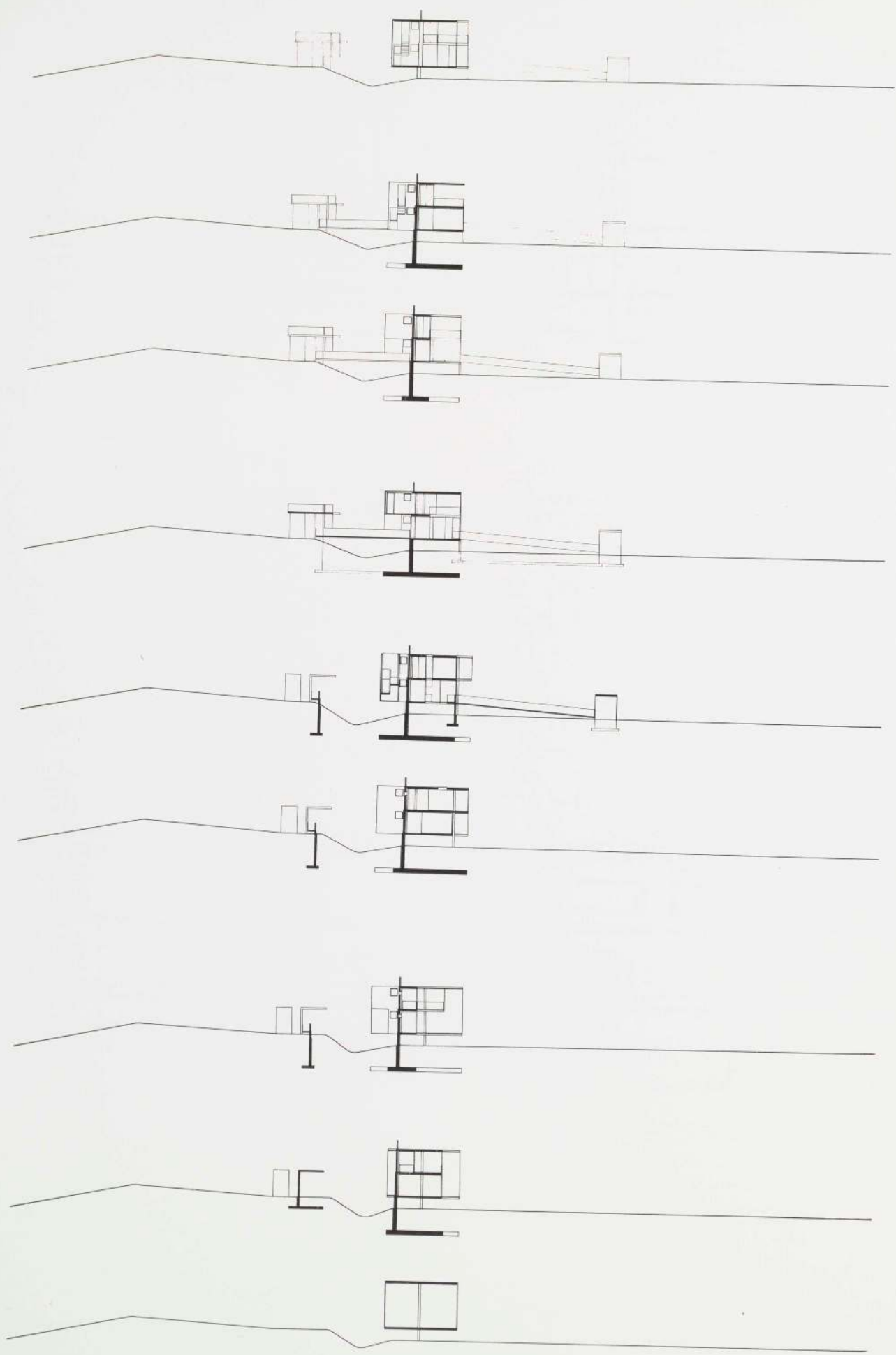

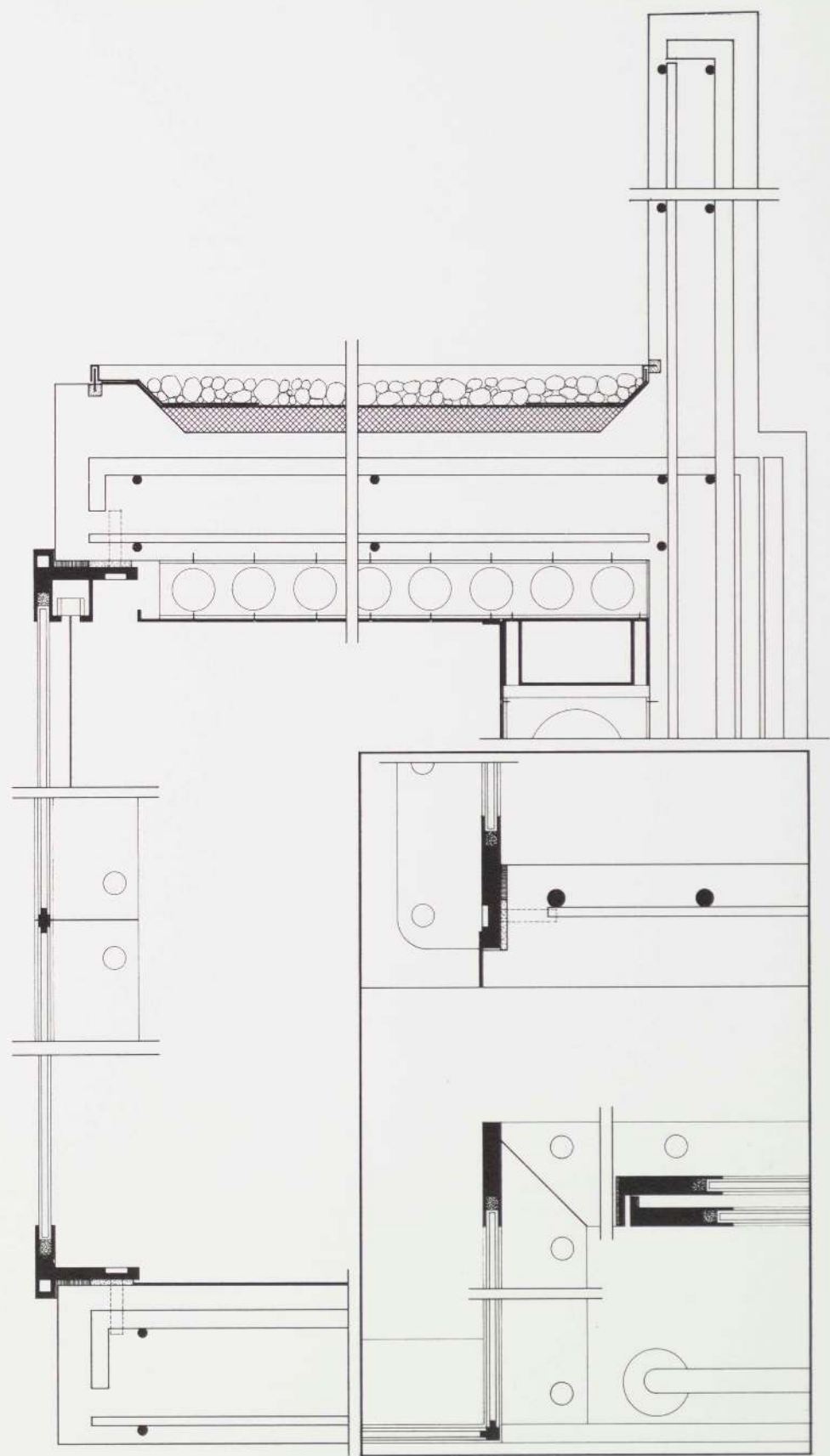

HOUSE/JOHN COLAMARINO.

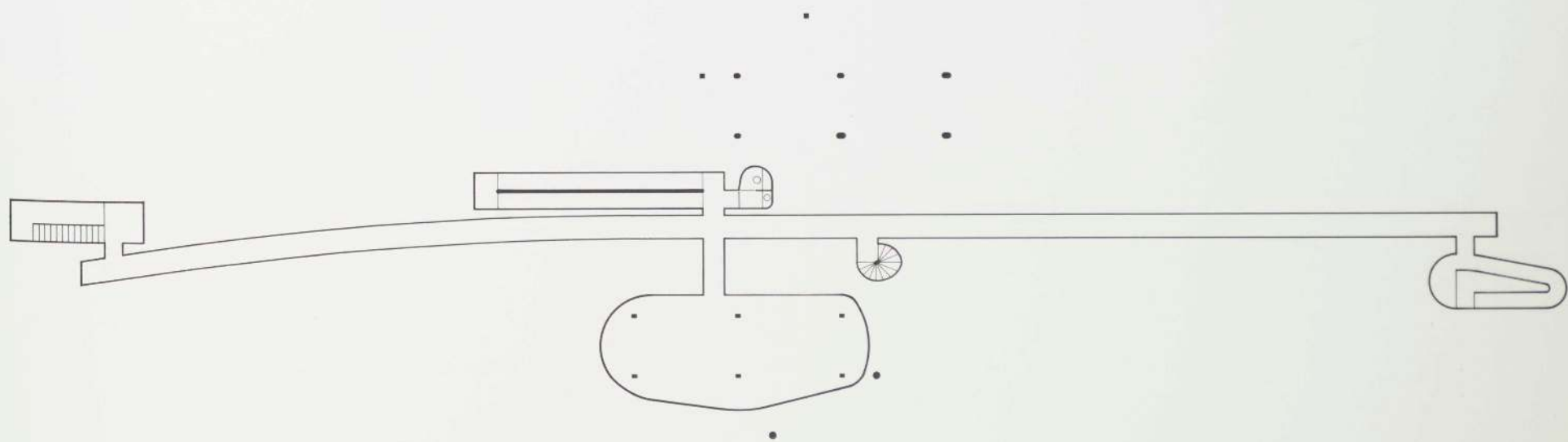
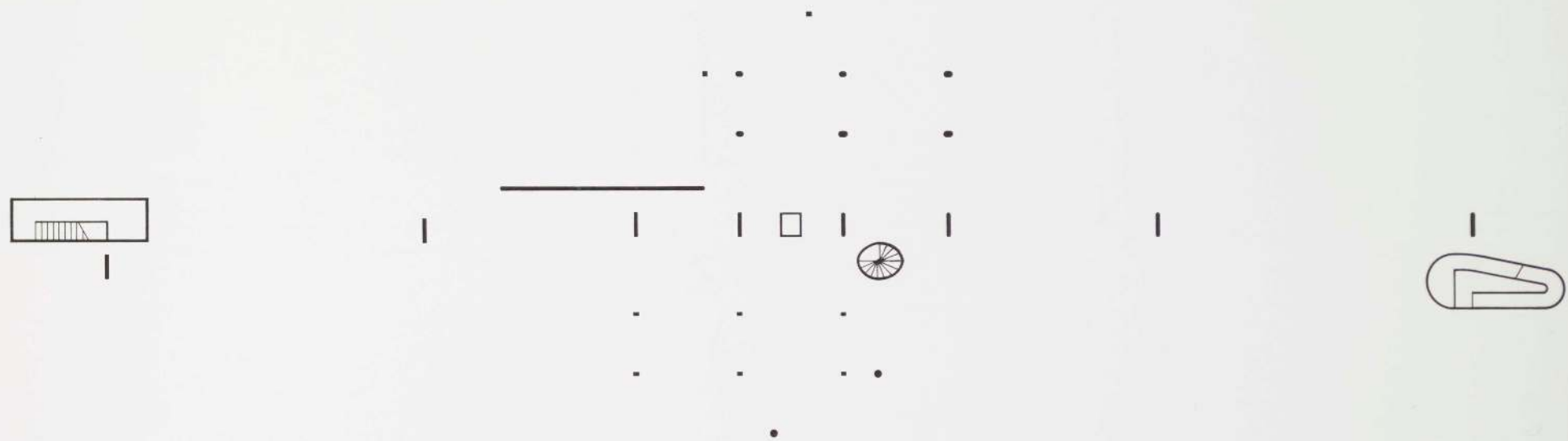

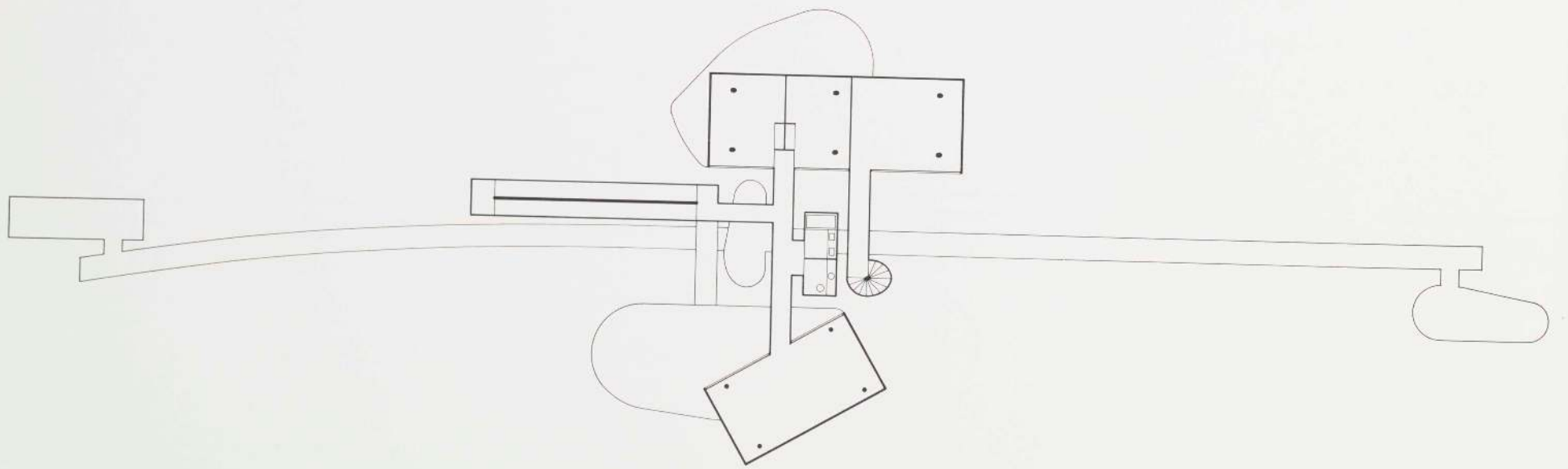
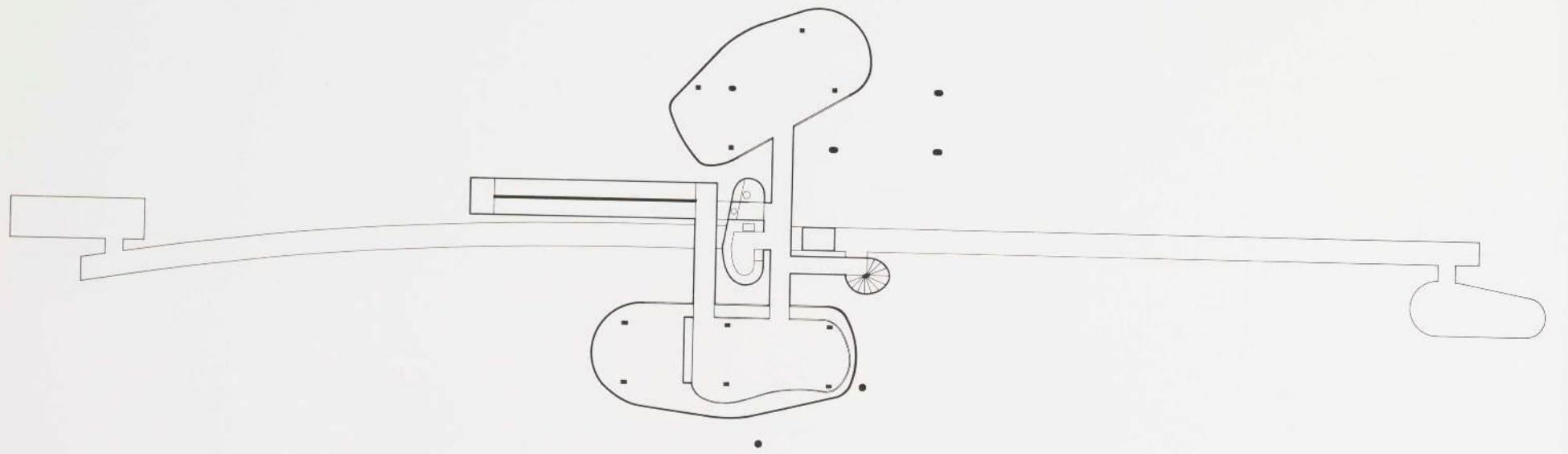

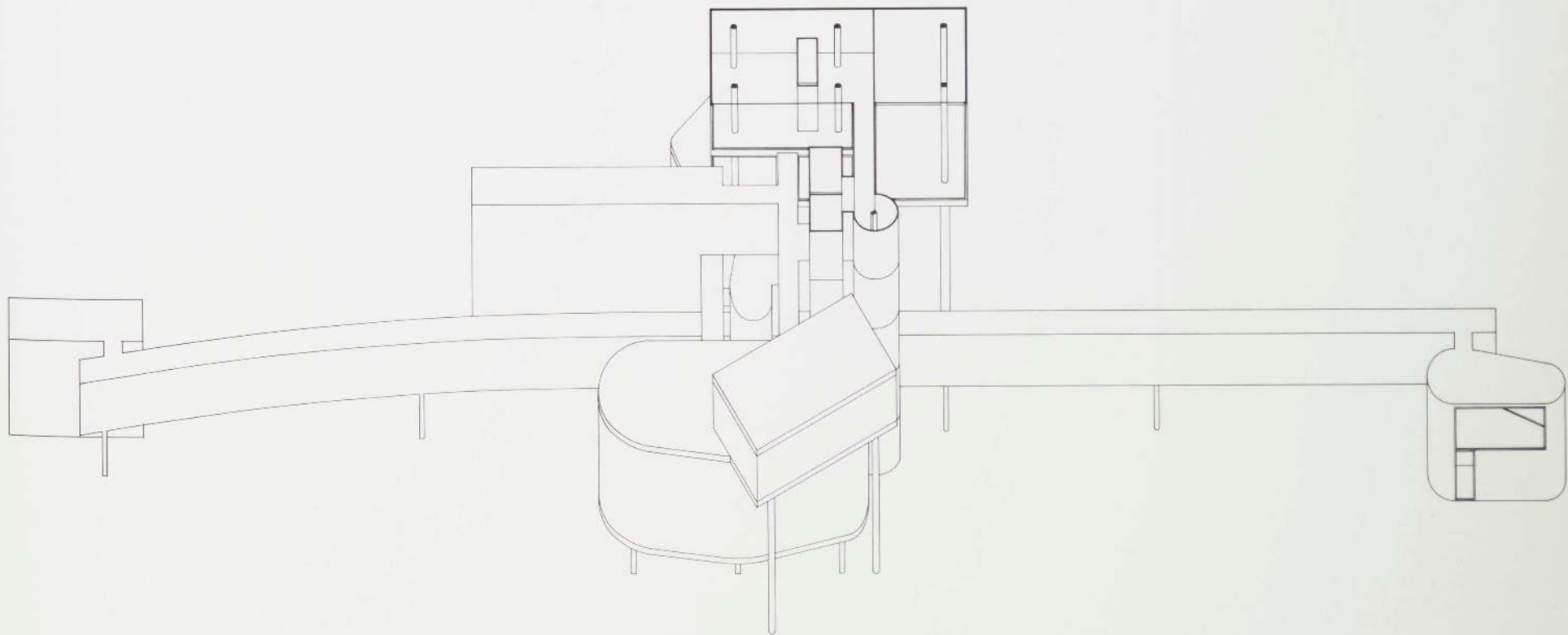
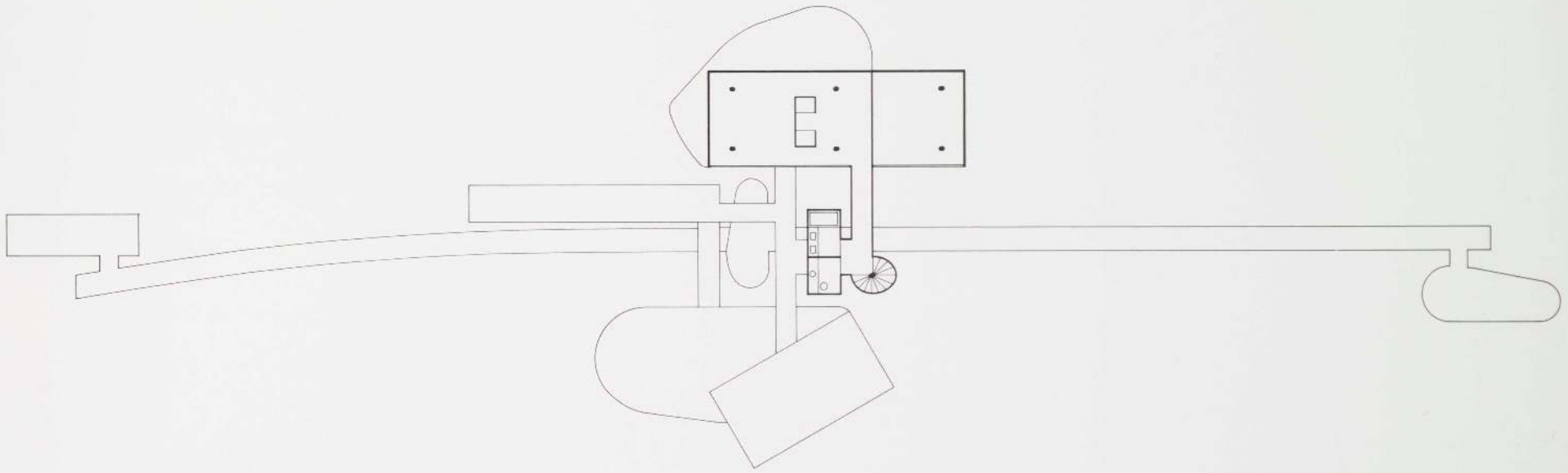

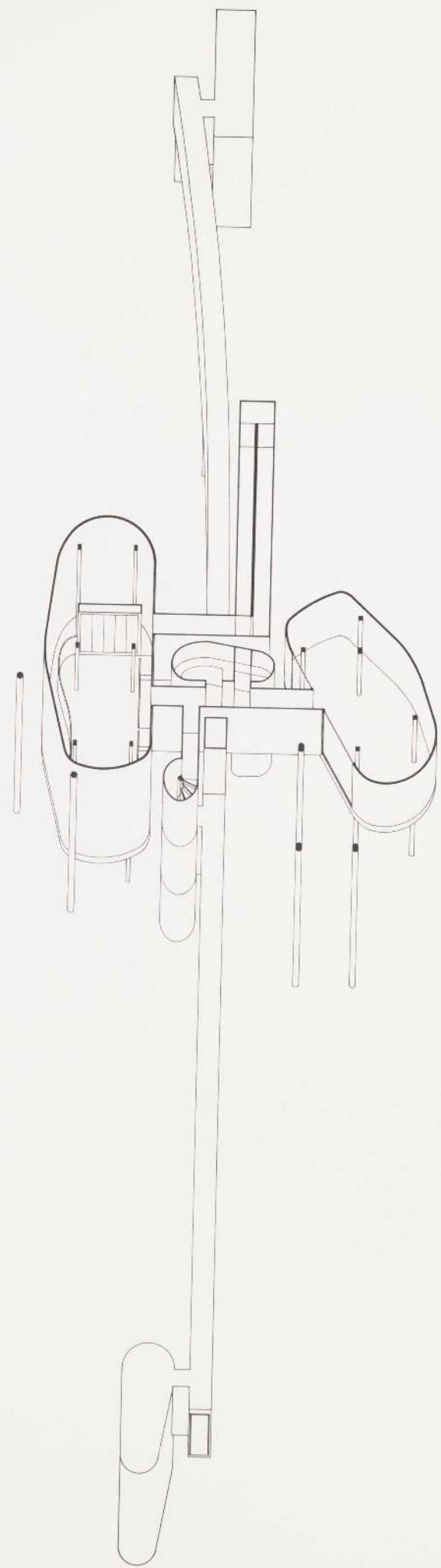
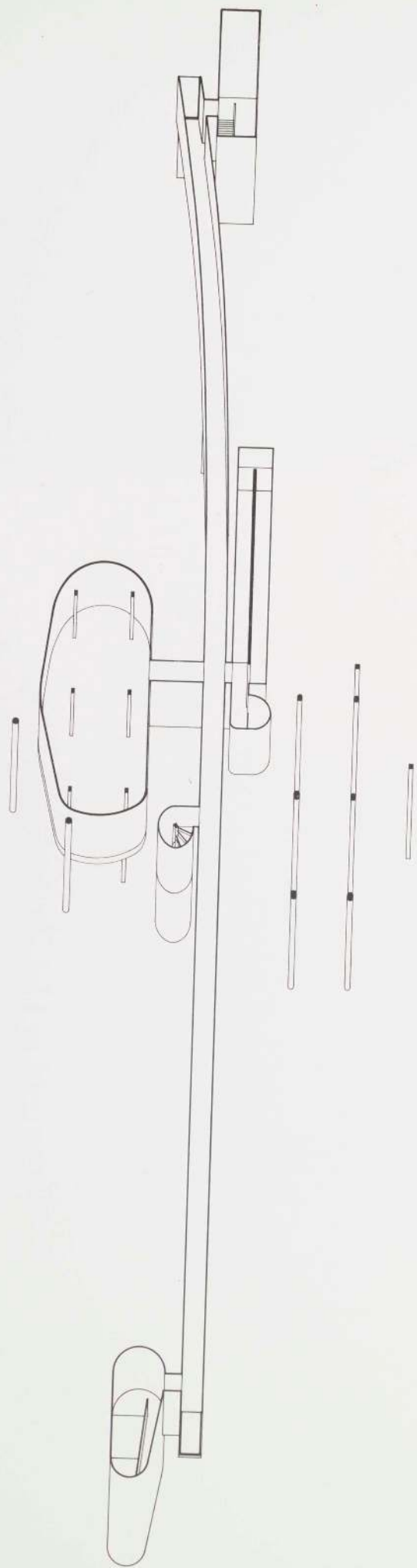

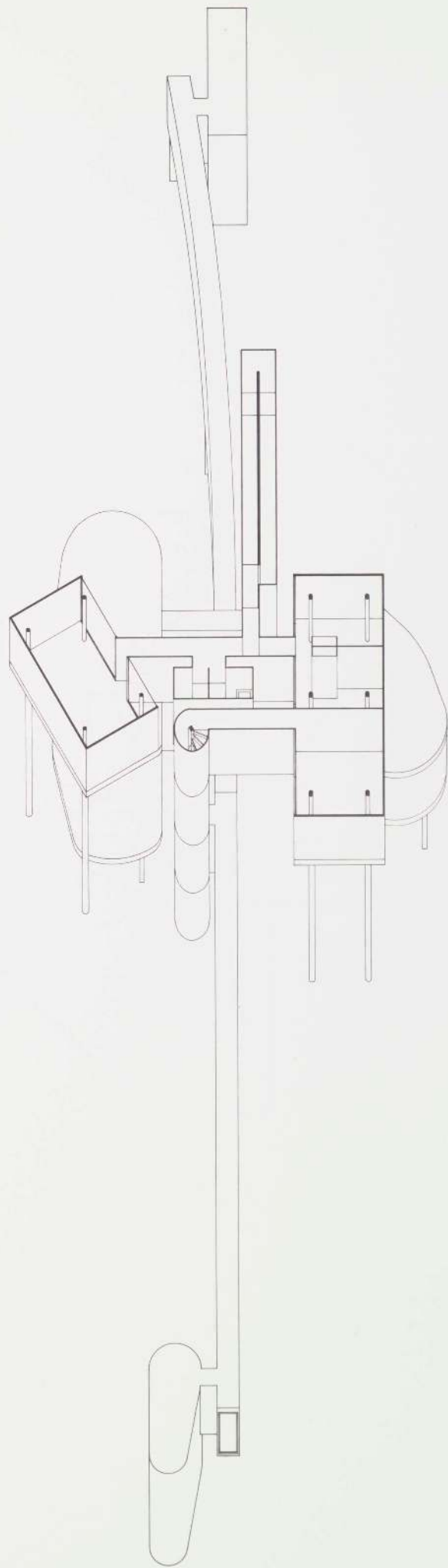

HOUSE/CARL STEIN.

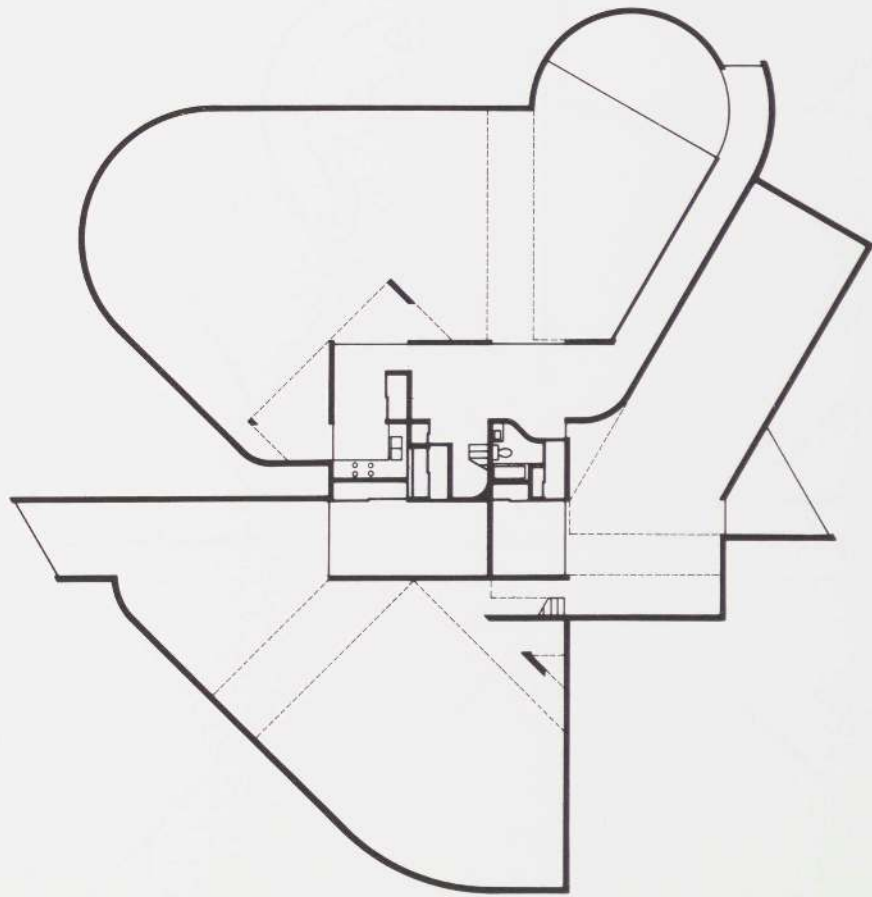

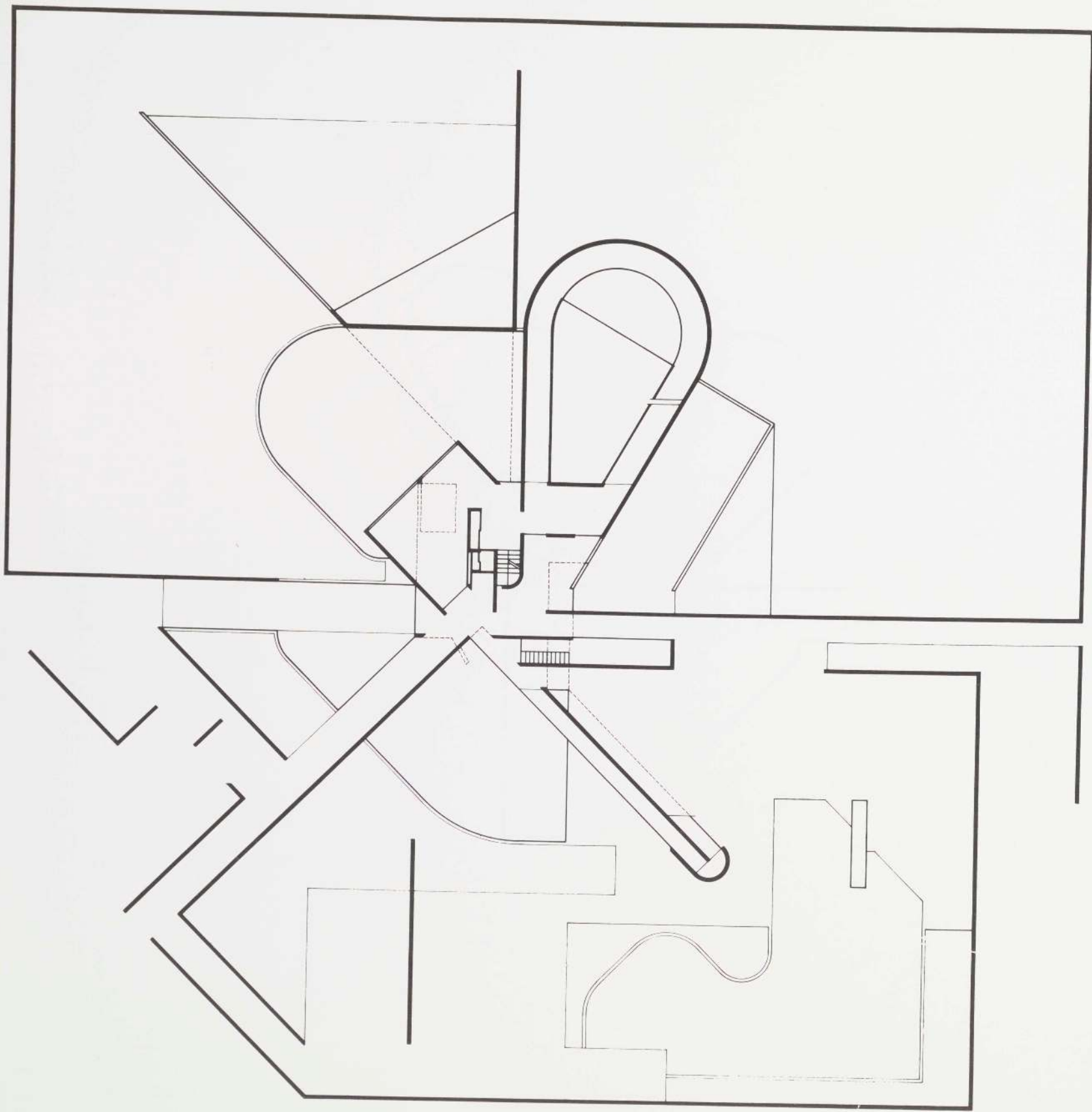

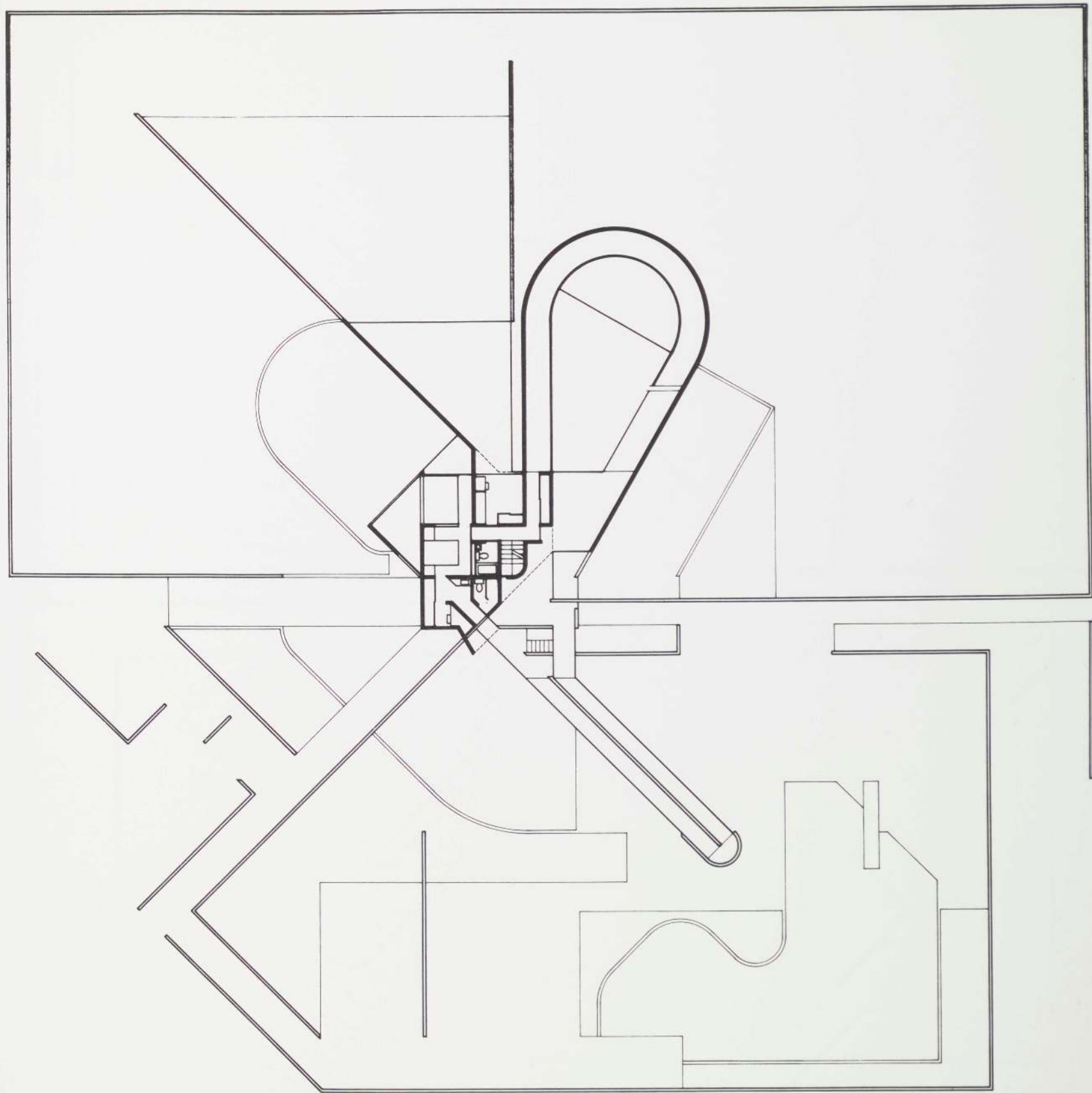

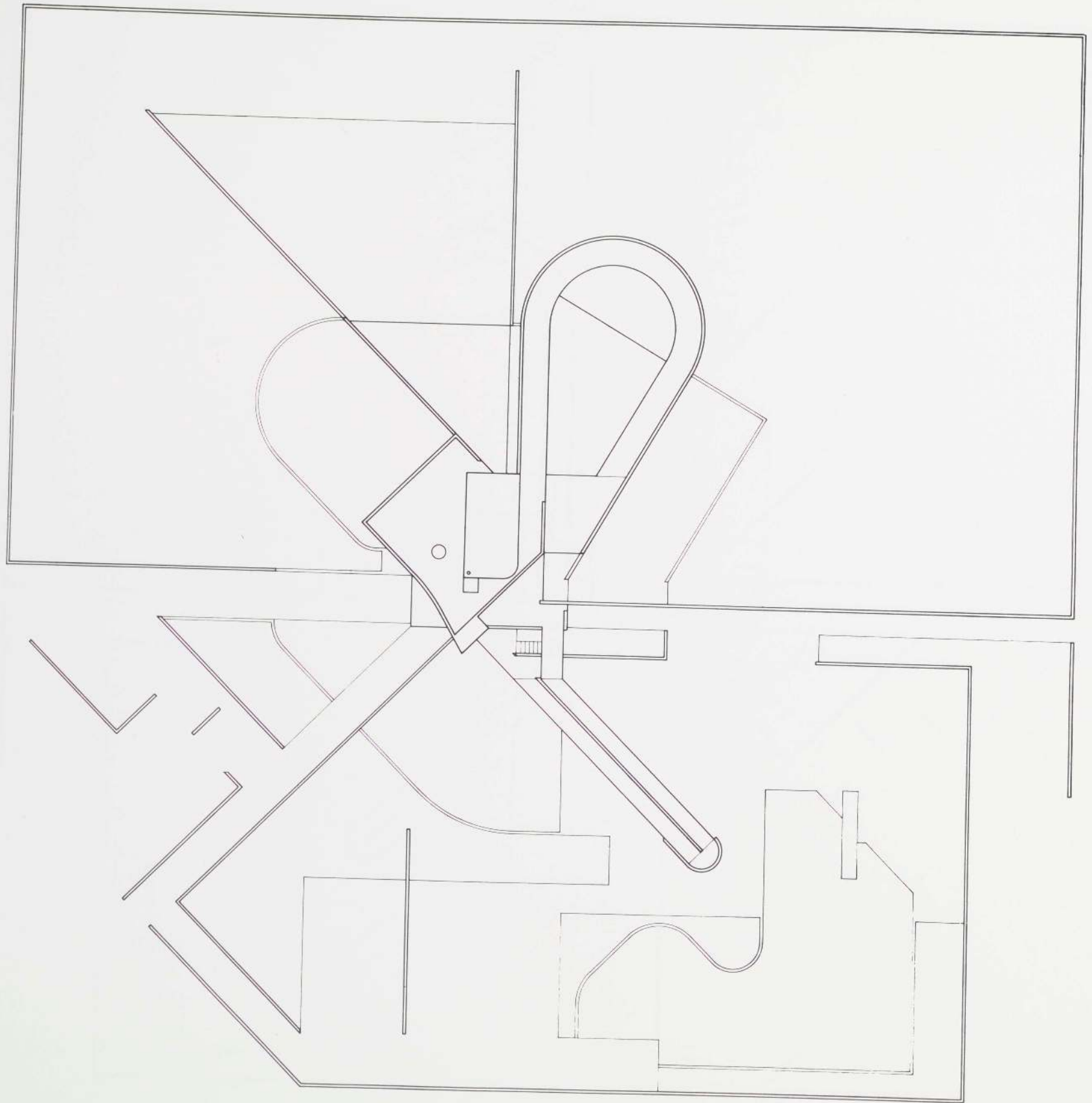

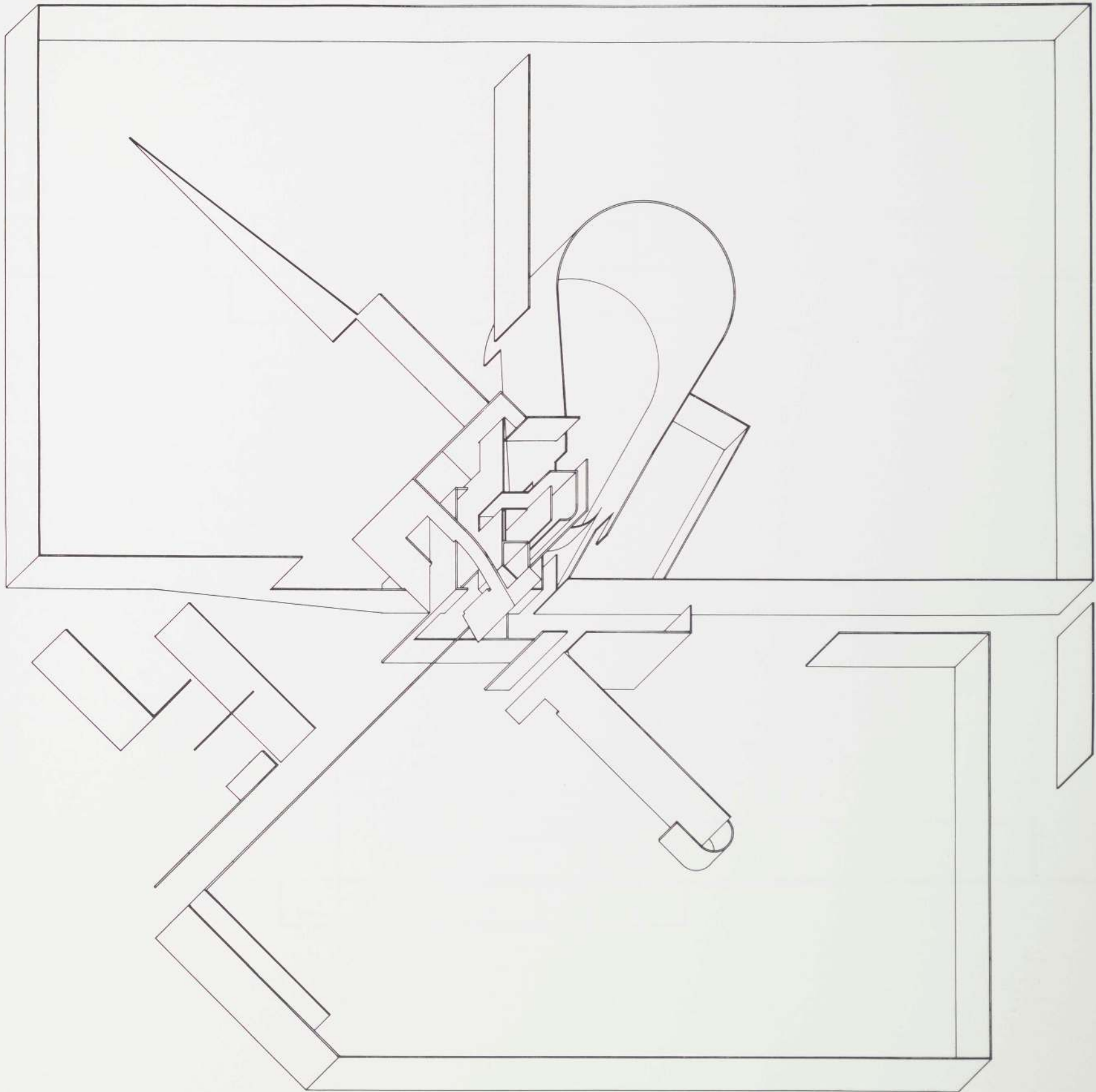

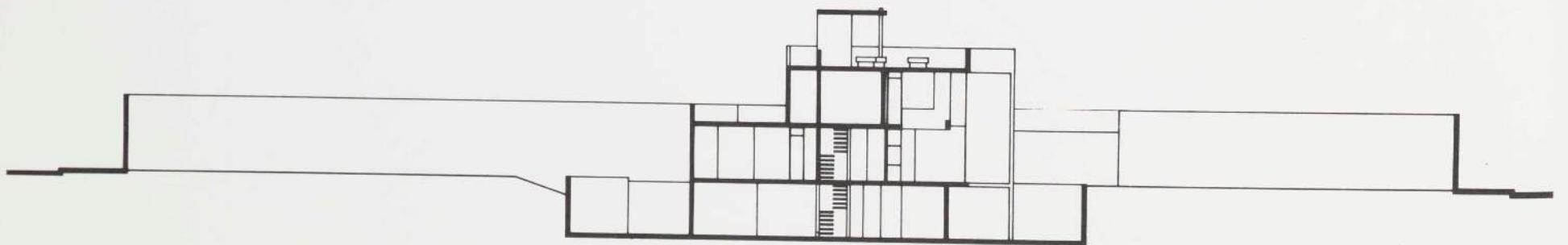
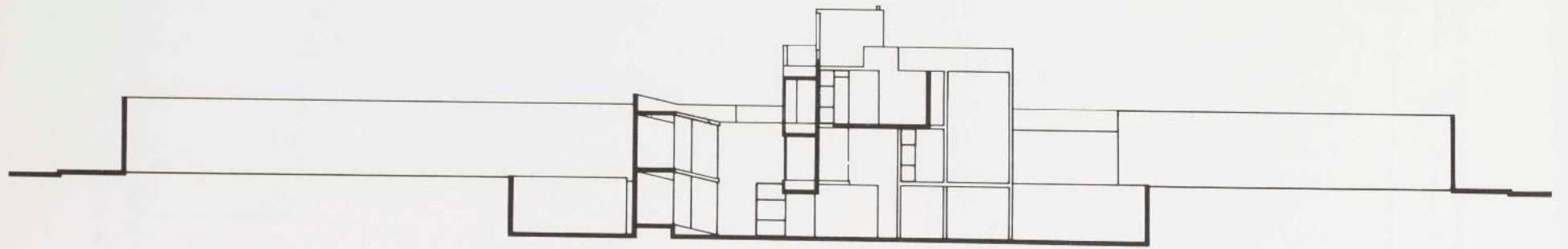

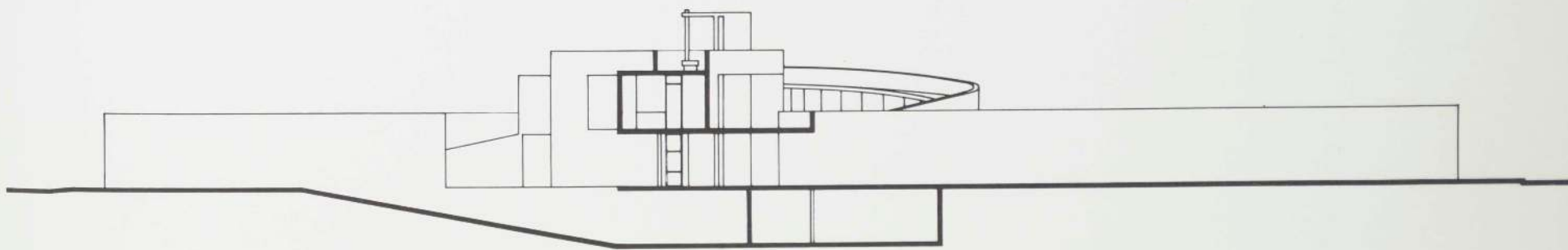
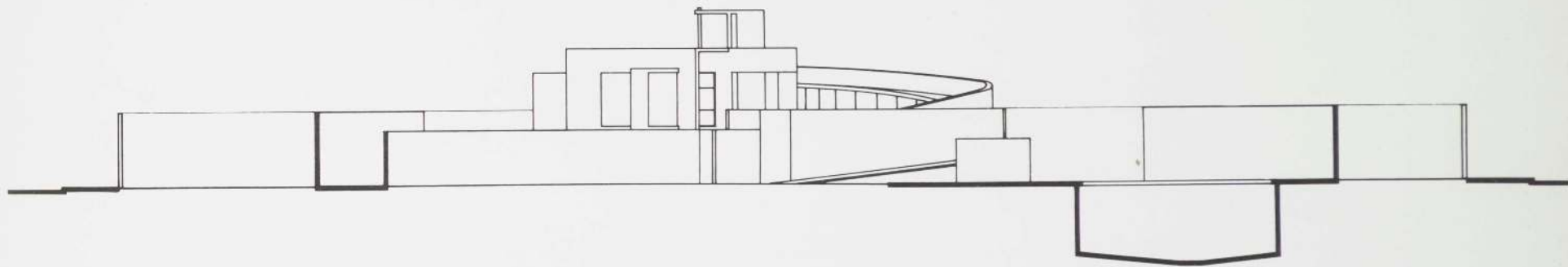

'GRIS' STUDY/RICHARD CHRISTOPH CORDTS. "This was the third or fourth book he had brought to the library. Every time he brought in a new book he looked a little older, a little more tired. He looked quite young when he brought in his first book. I can't remember the title of it, but it seems to me the book had something to do with America. "What's this one about?" I asked, because he looked as if he wanted me to ask him something. "Just another book", he said. I guess I was wrong about him wanting me to ask him something."
'The Abortion: An Historical Romance 1966', Richard Brautigan

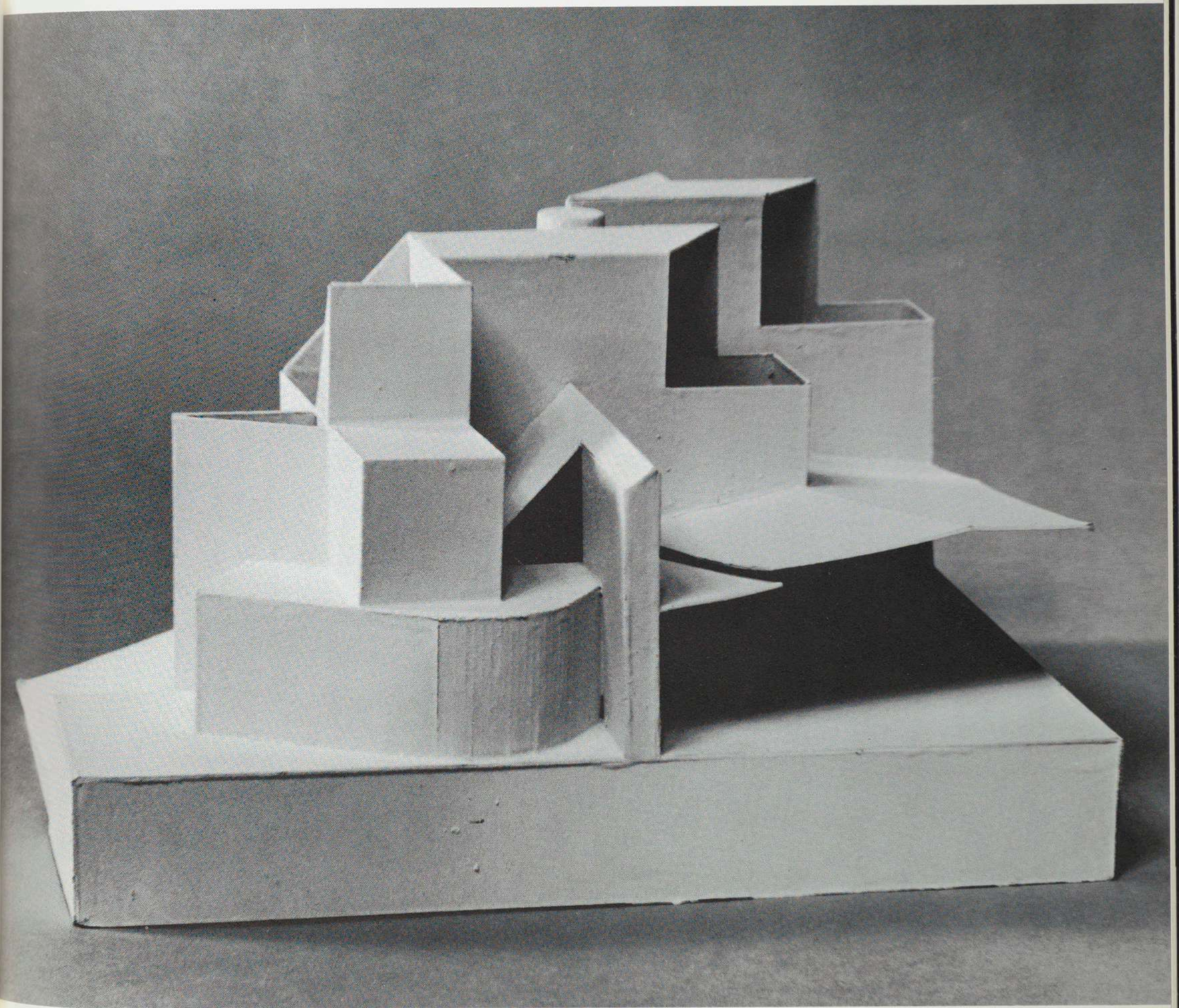

GRIS HOUSE/MICHAEL DOLINSKI. The proposition was to design a residence in the intention of Juan Gris. The idea was to translate the notions of a specific Cubist painter into a controlled three-dimensional envelope of space. This involved an analysis and re-evaluation of what Cubism was in painting, sculpture and architecture. Since Gris was primarily a painter, the problem of translation from the implied in painting to its abstraction in architectonic terms was obvious. The objective was to synthesize a program and design simultaneously. The program was to be real and workable, and the design was to unify the program in context with the formal intention. The mainstream of inspiration came from Gris' earlier work. My primary concern was spatial; where the layering or superimposition of ambiguous spaces was to yield an explicit composition. One could call it poly-spatial. The shapes of these spaces are programmatic, and the repetition of their theme is meant to imply unity. The Cubist notion of centrality resides in the central spine. This operates in one instance as an elongated slot of circulation space, and in another as a retaining wall reaching out to tie back an extension. The organization of the structure exists along and at right angles to this spine, warping from level to level but always tightly compressed into it. Tension is produced as a result of these extensions and compressions which become apparent in the elevations as one circles around the structure and in the comparison of longitudinal versus transverse sections. Thematic unity eases this tension and therefore, I think, the composition becomes dynamically stable.

of
e-
l,
n
n
-
k.
n
e
.
l
o
t
e
n

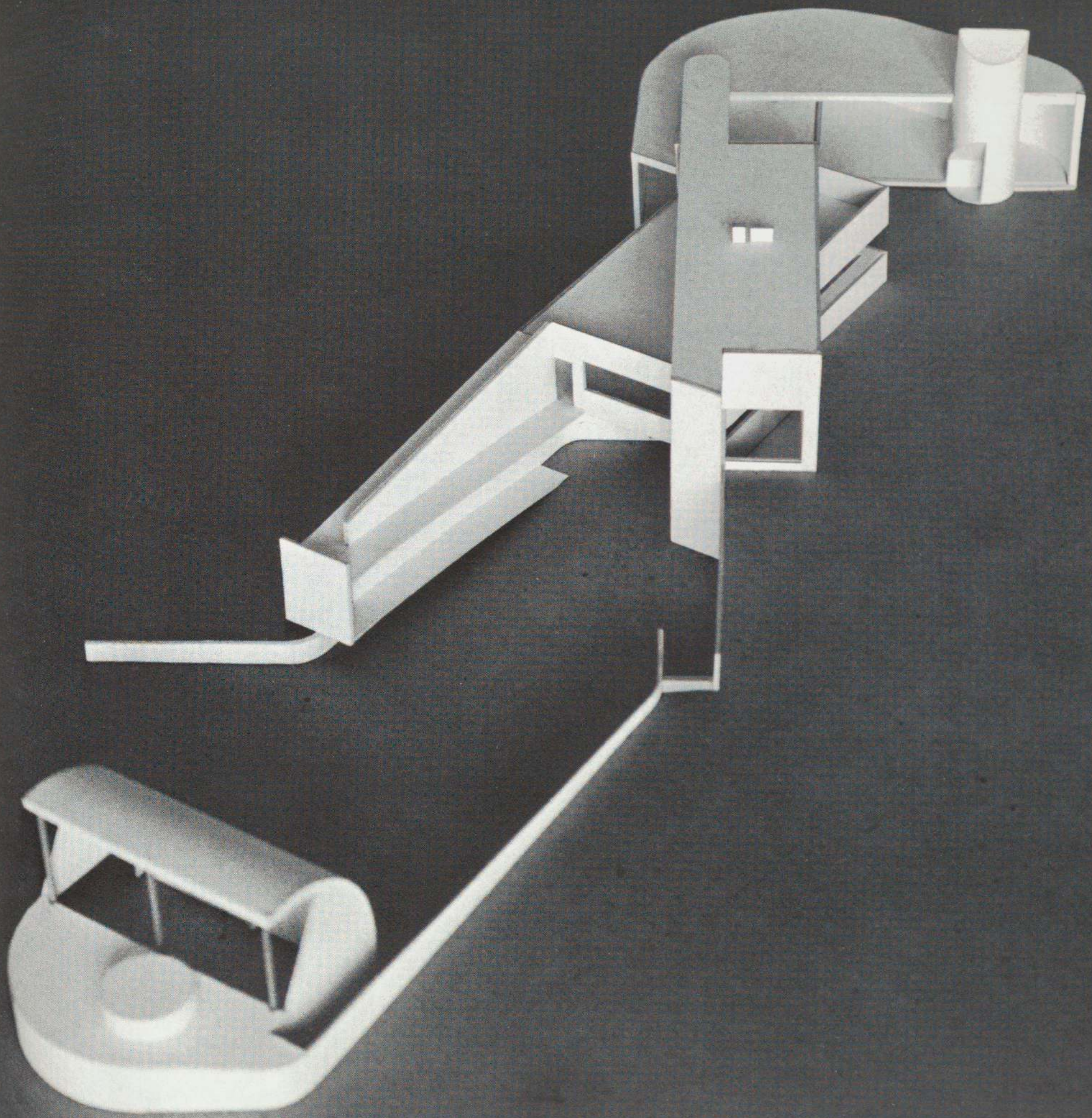

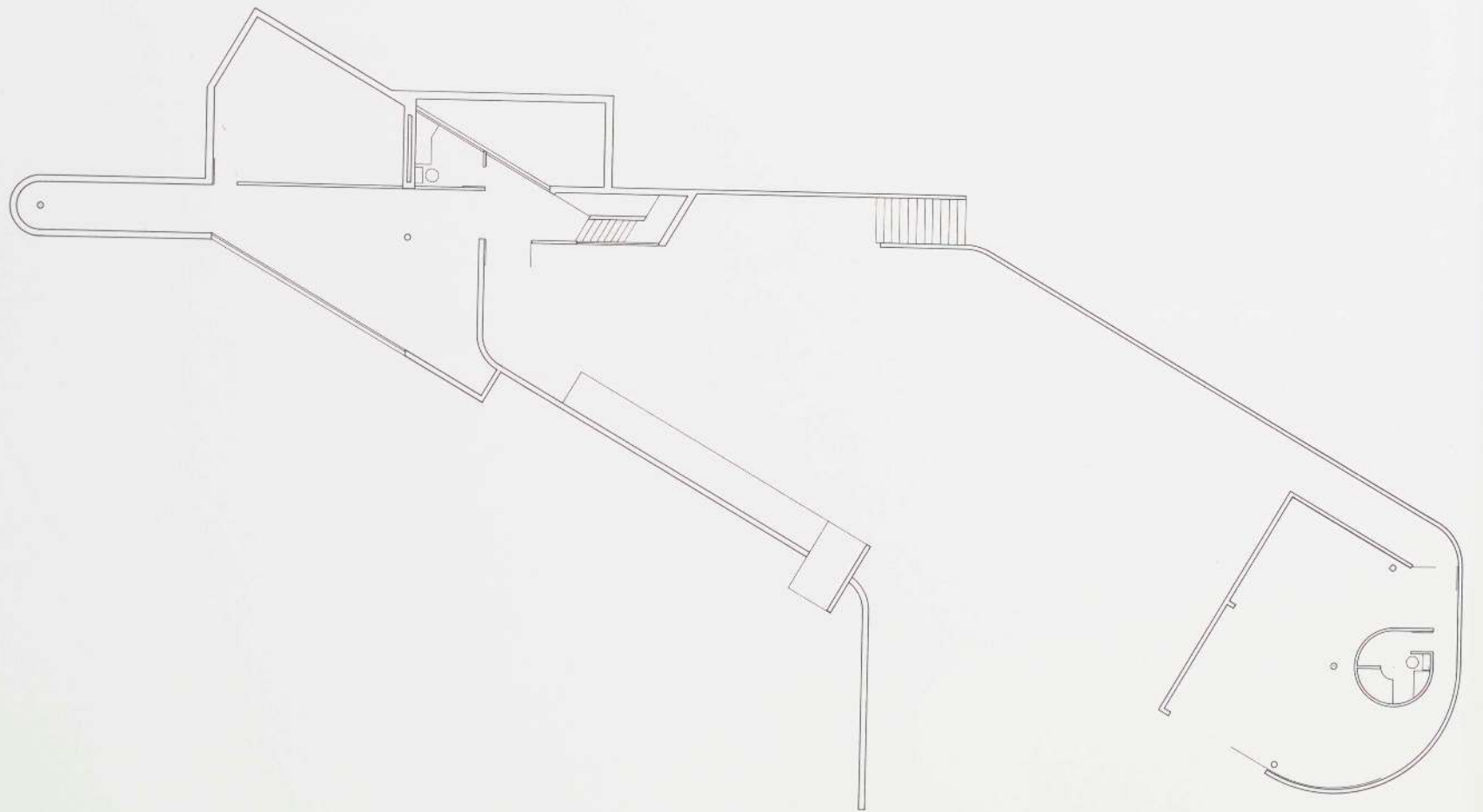

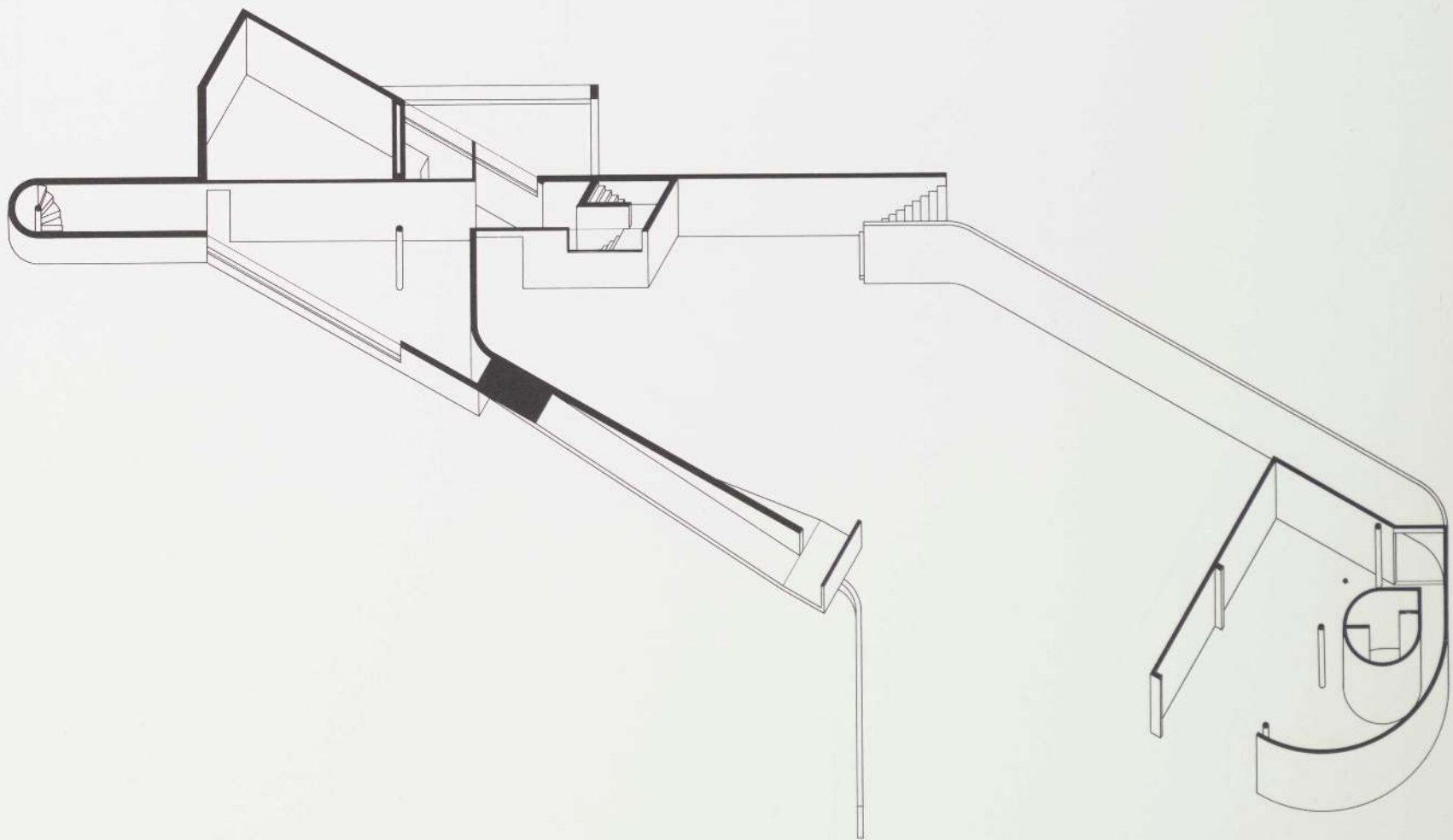

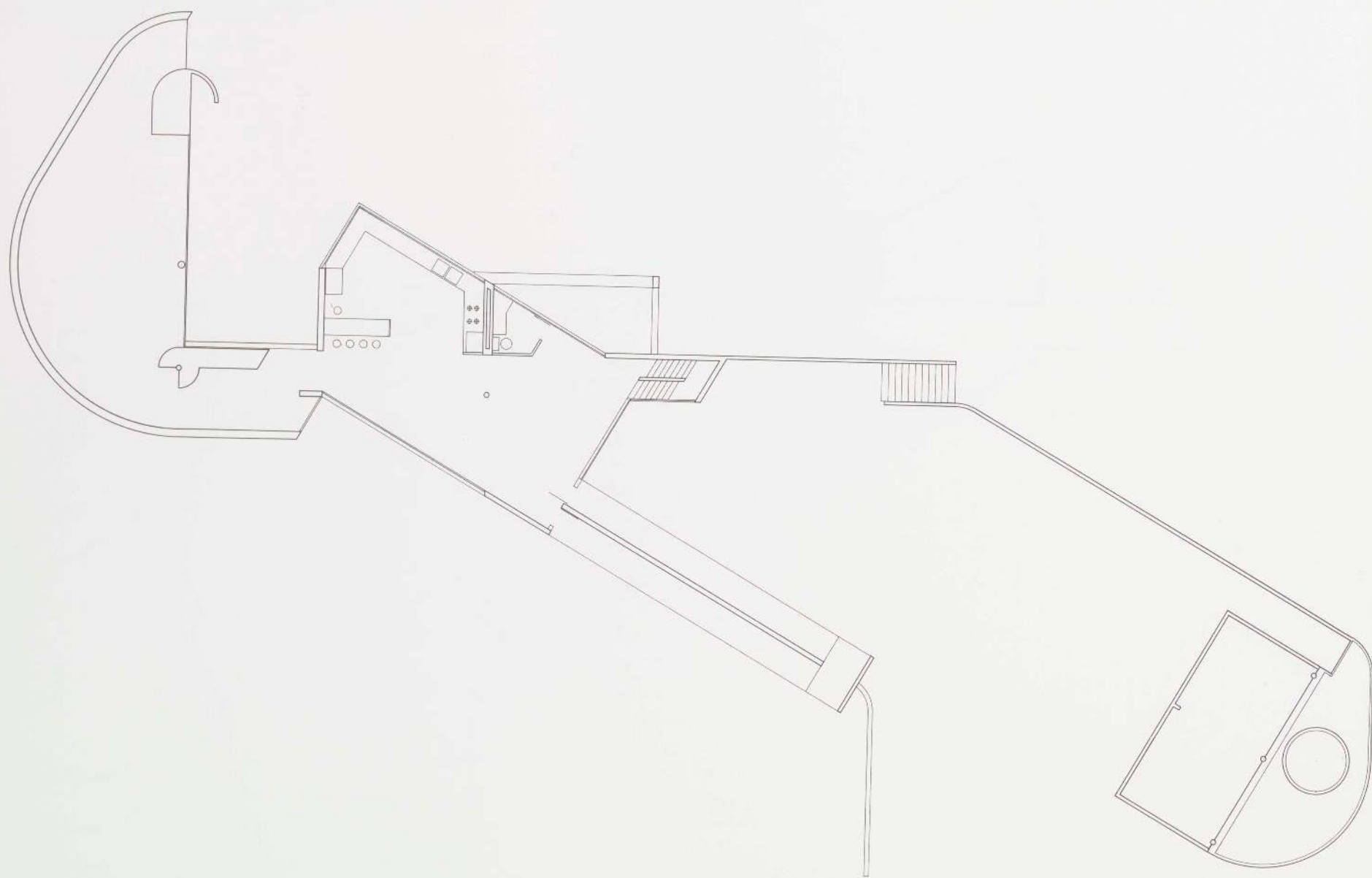

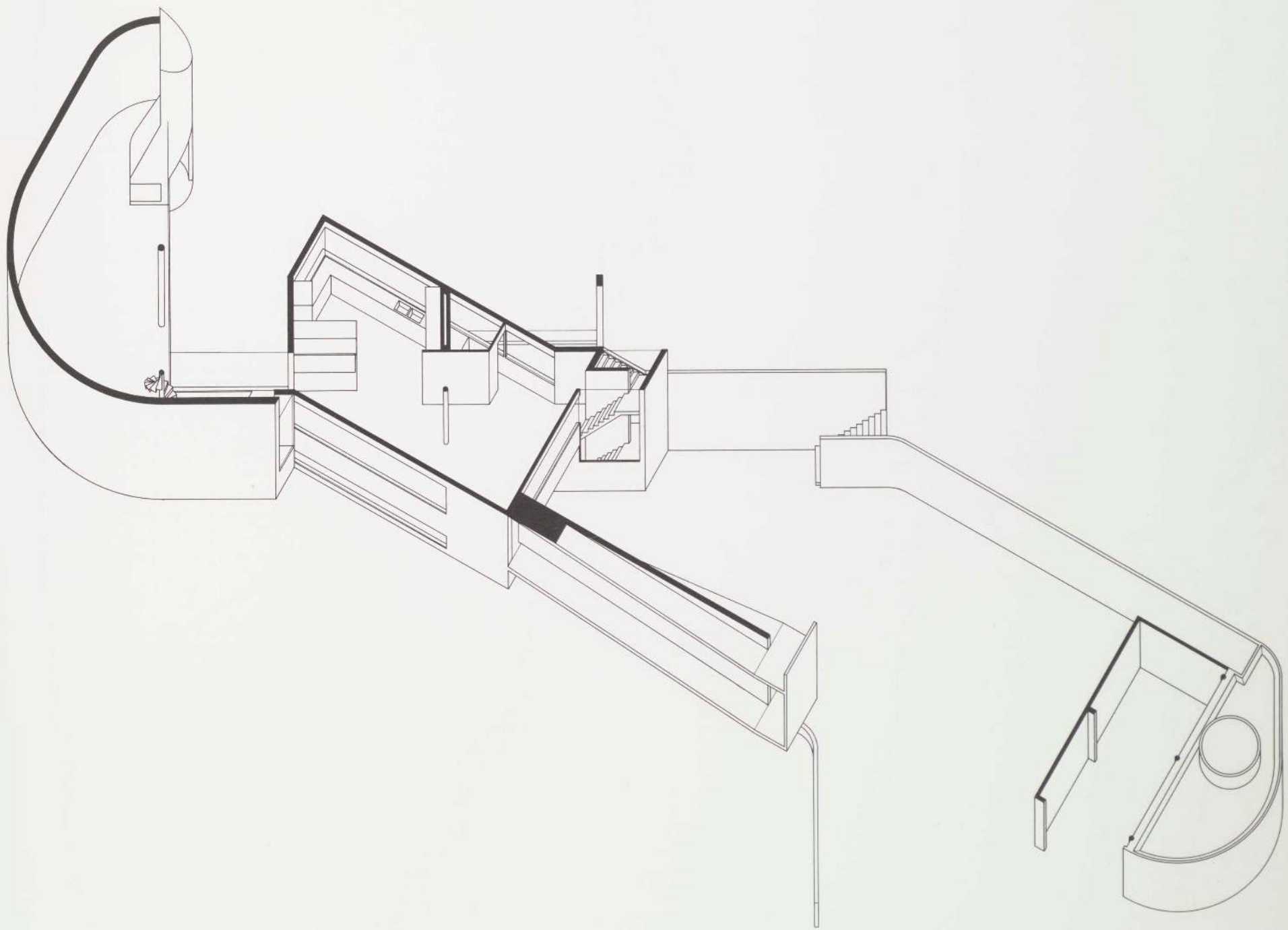

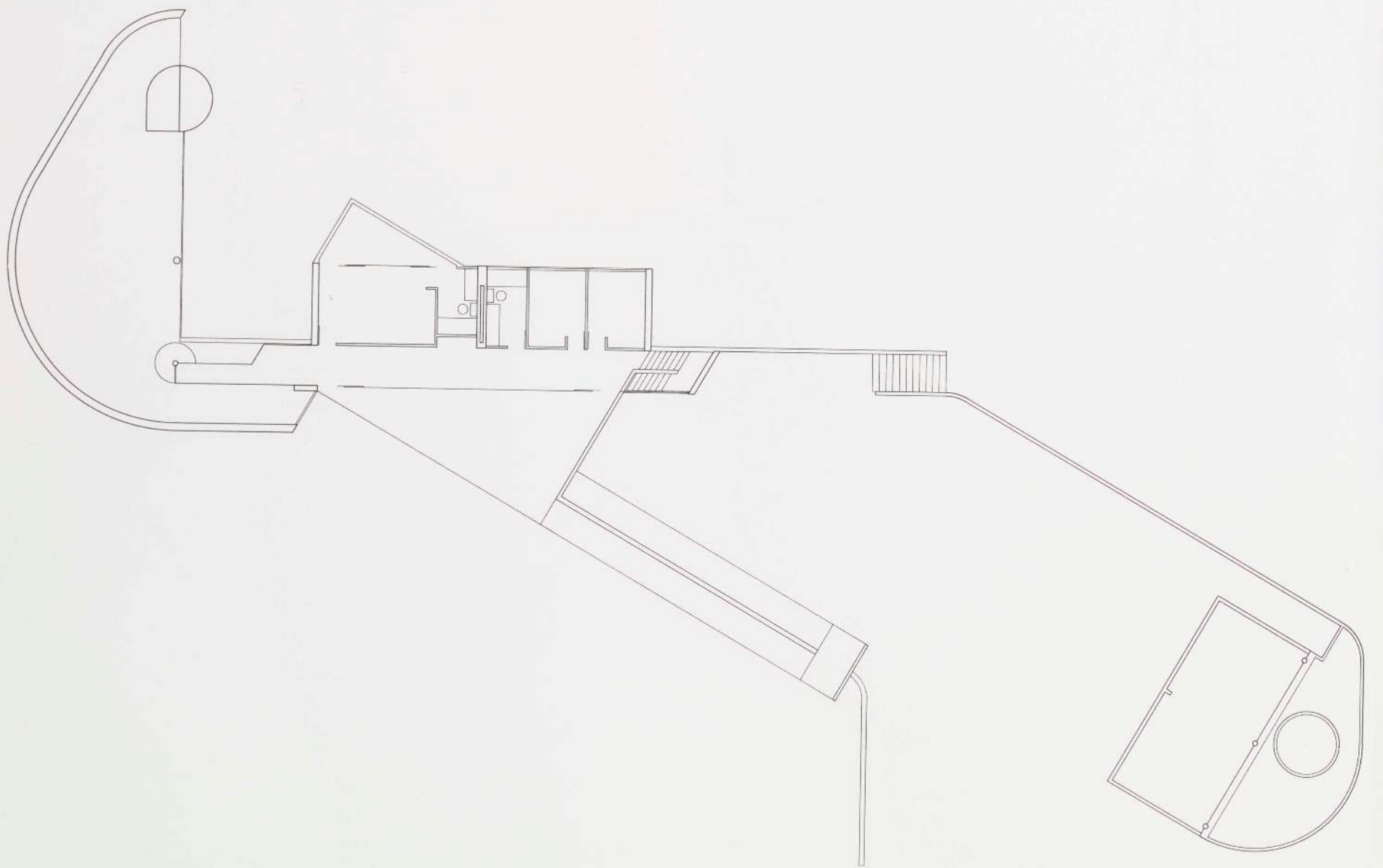

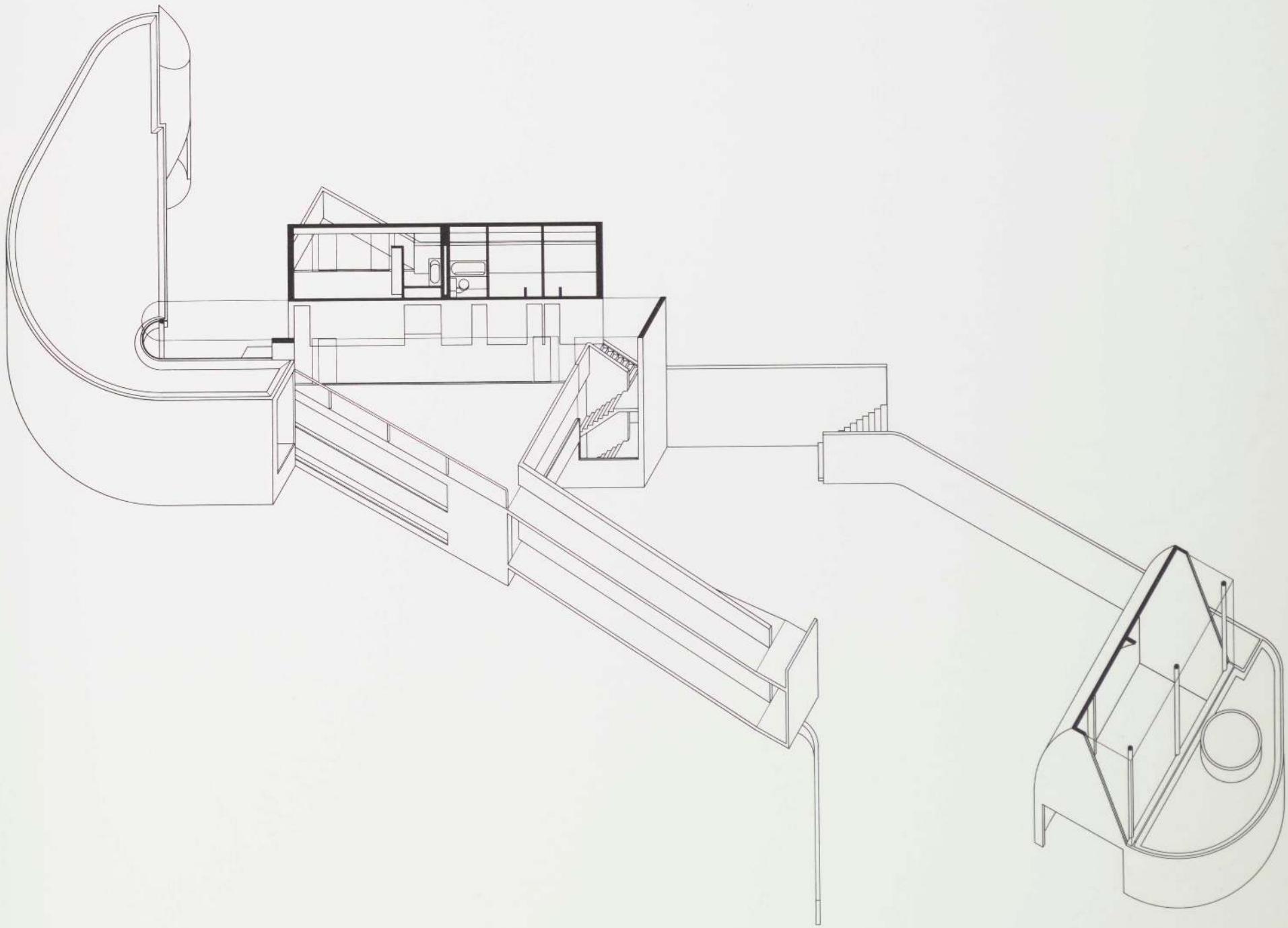

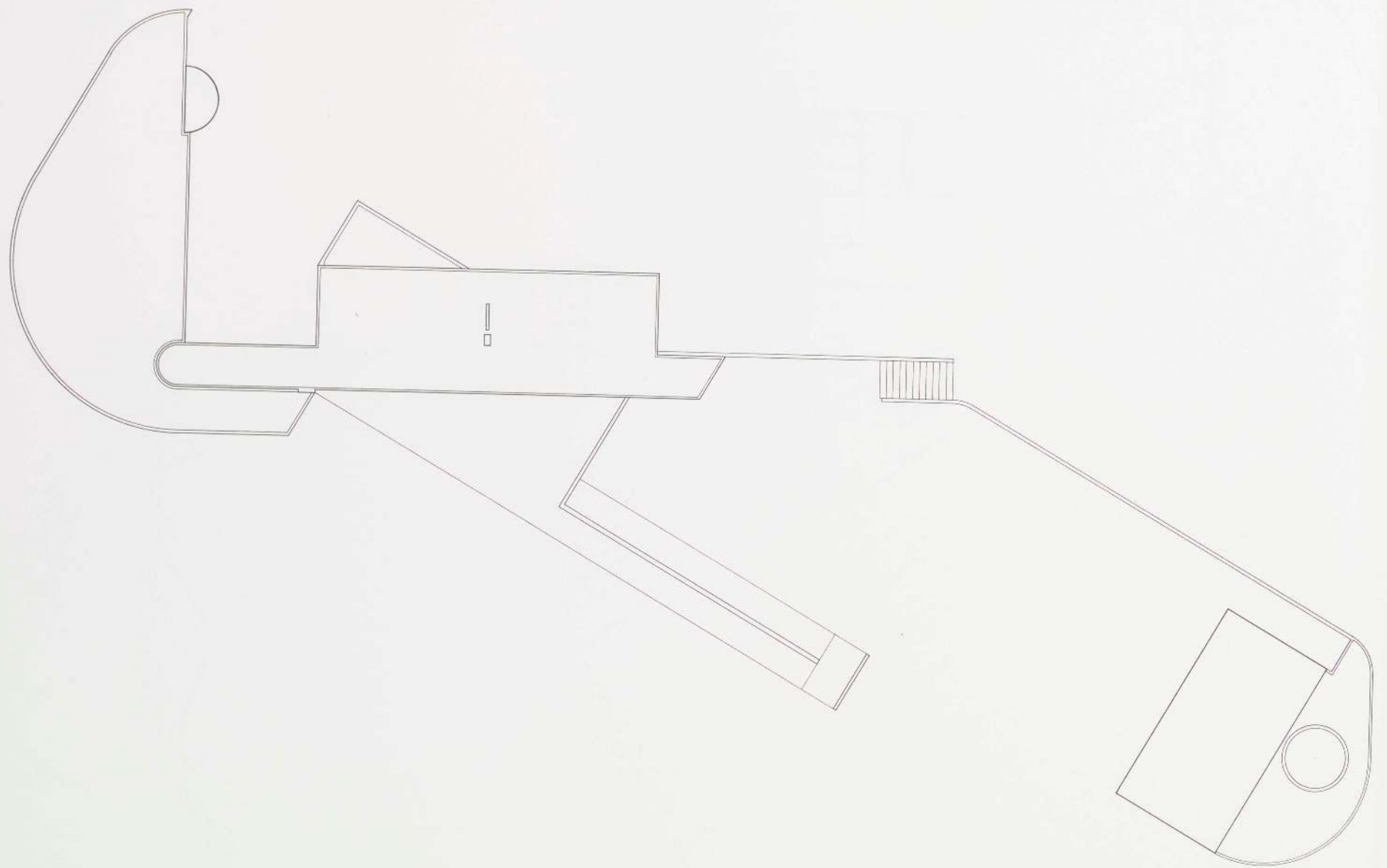

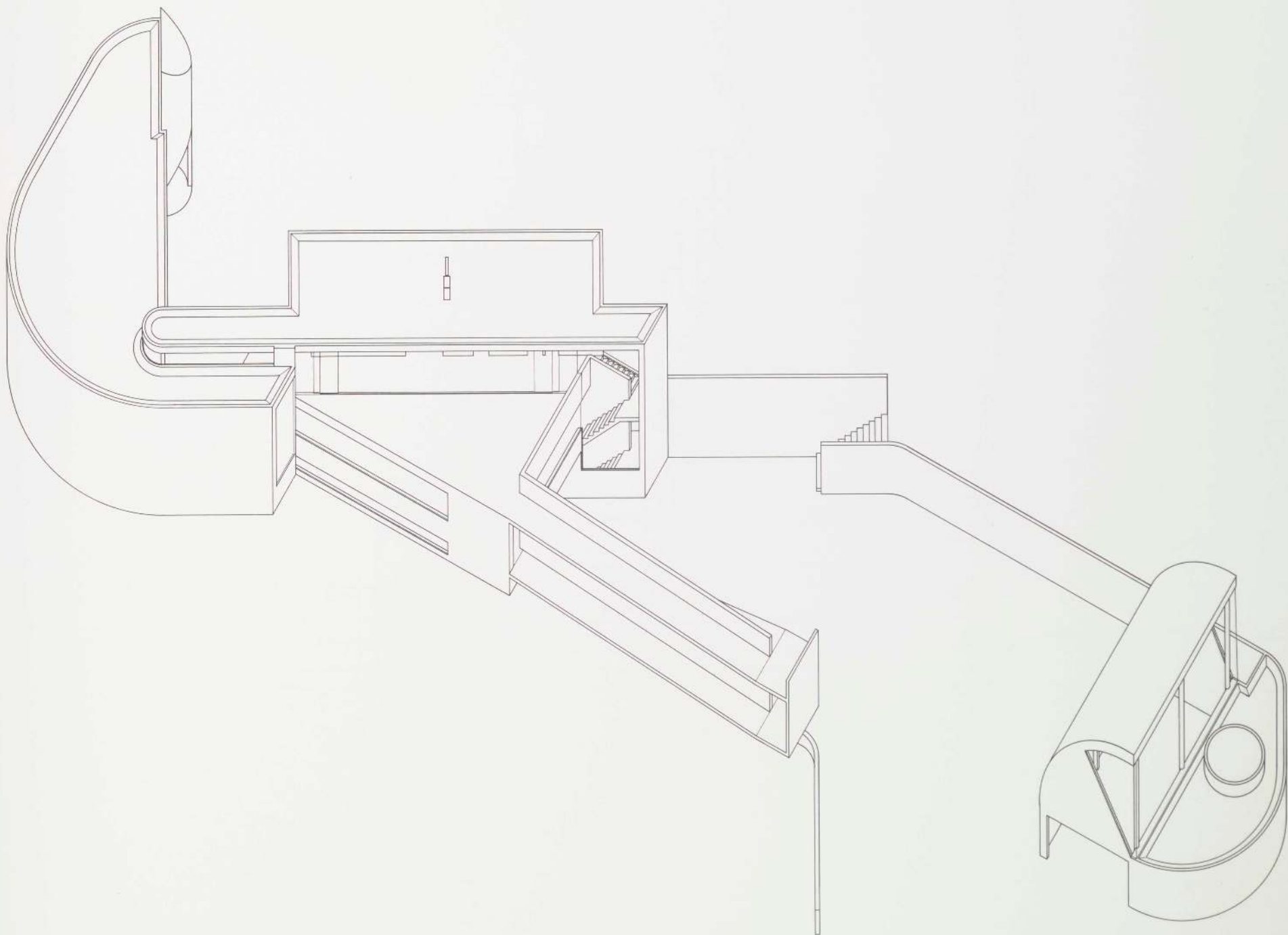

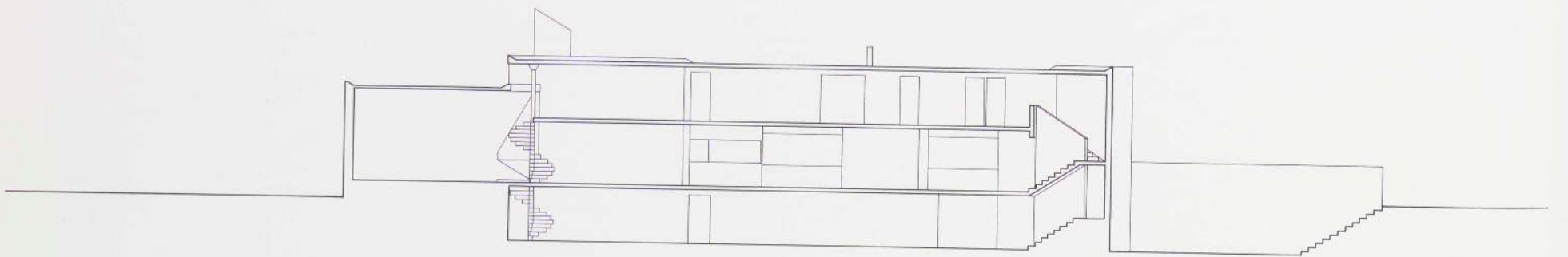
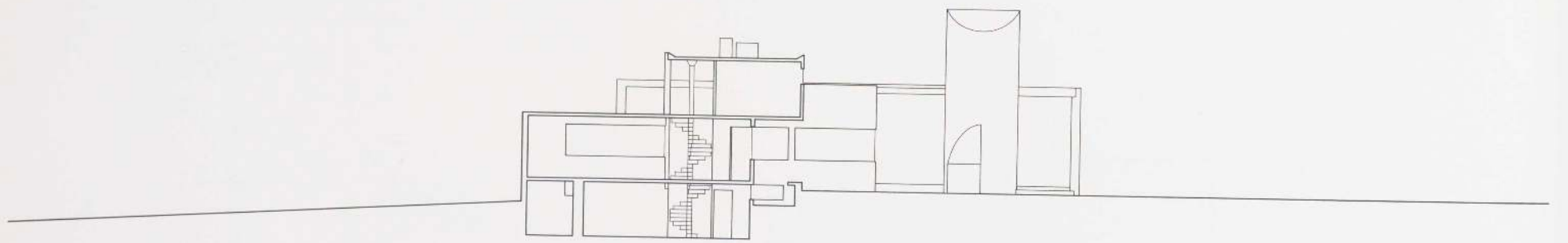

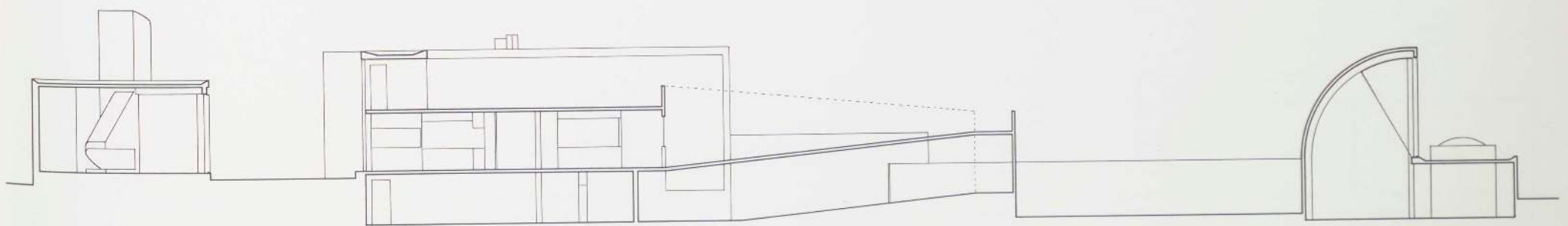

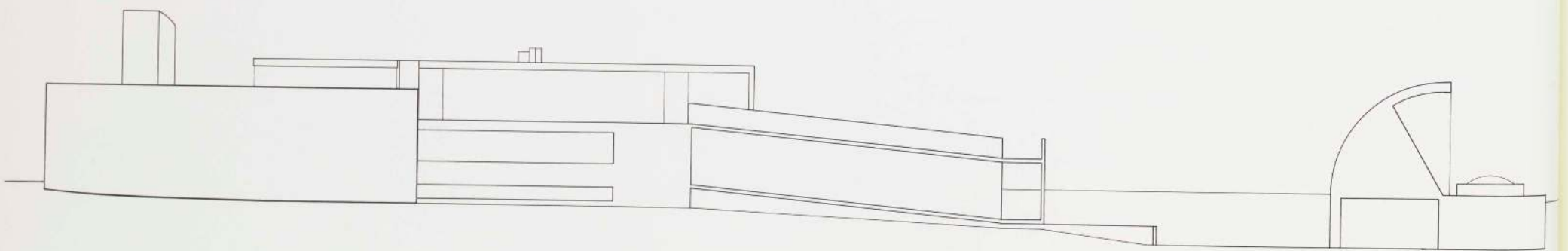
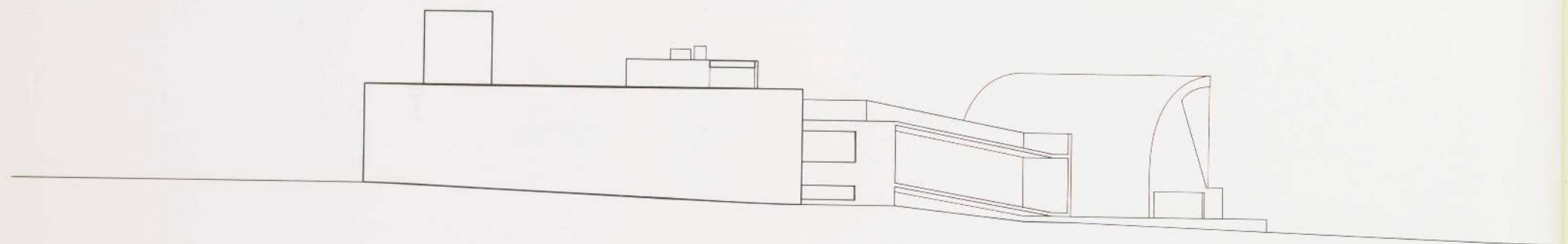

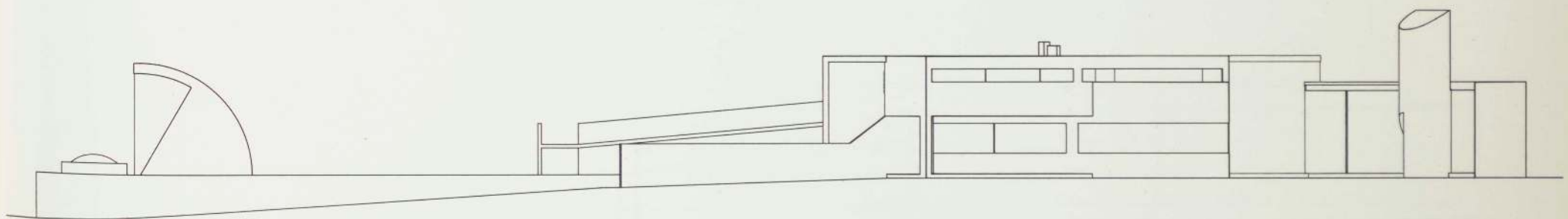
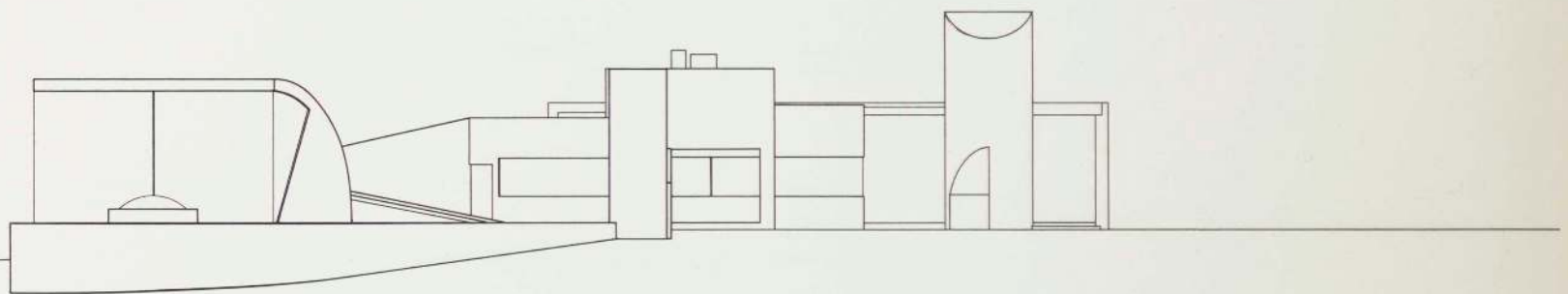

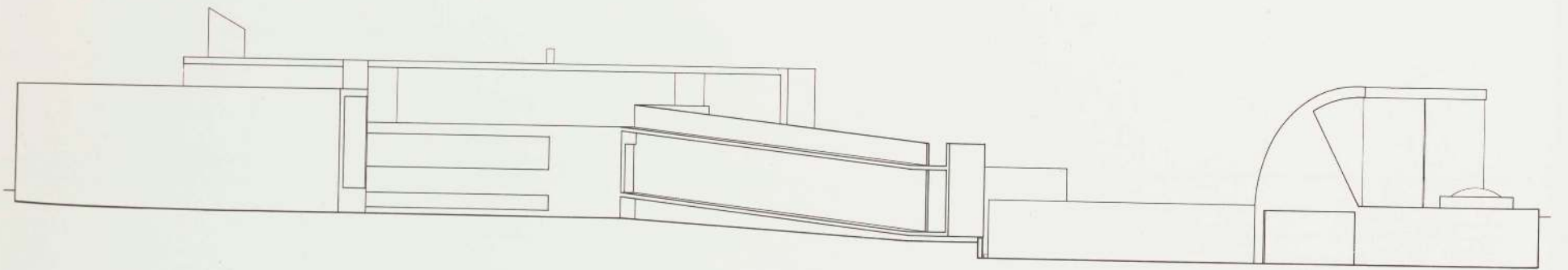
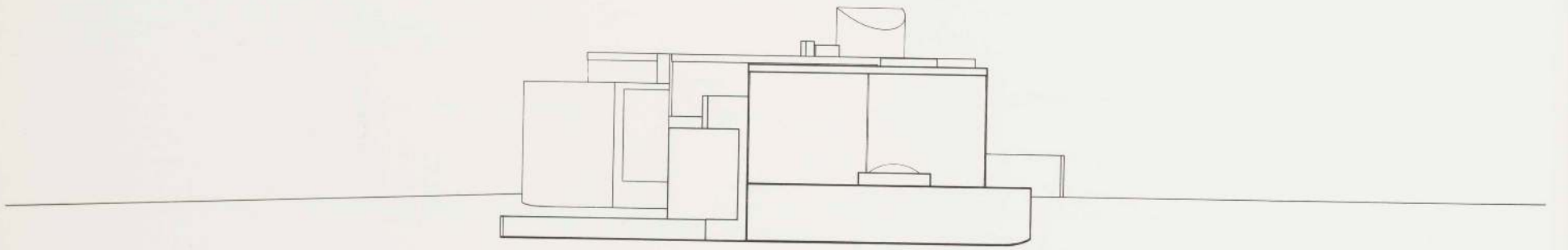

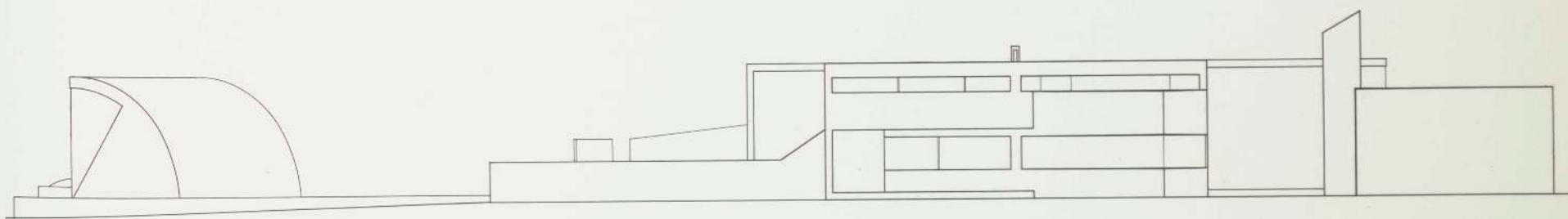
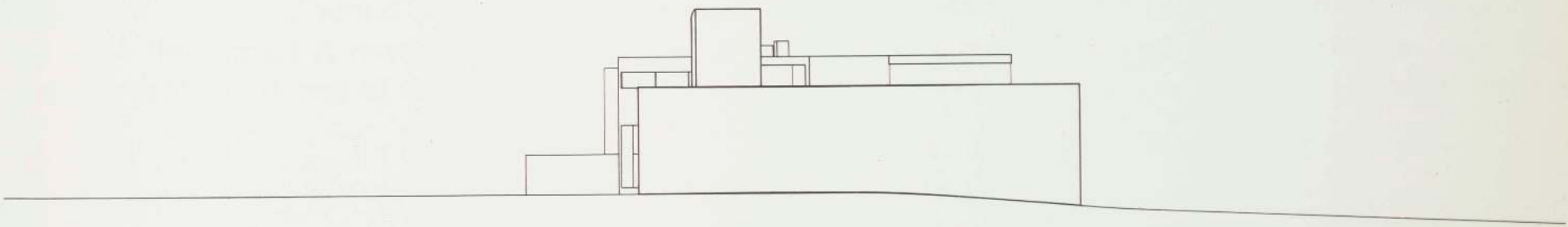

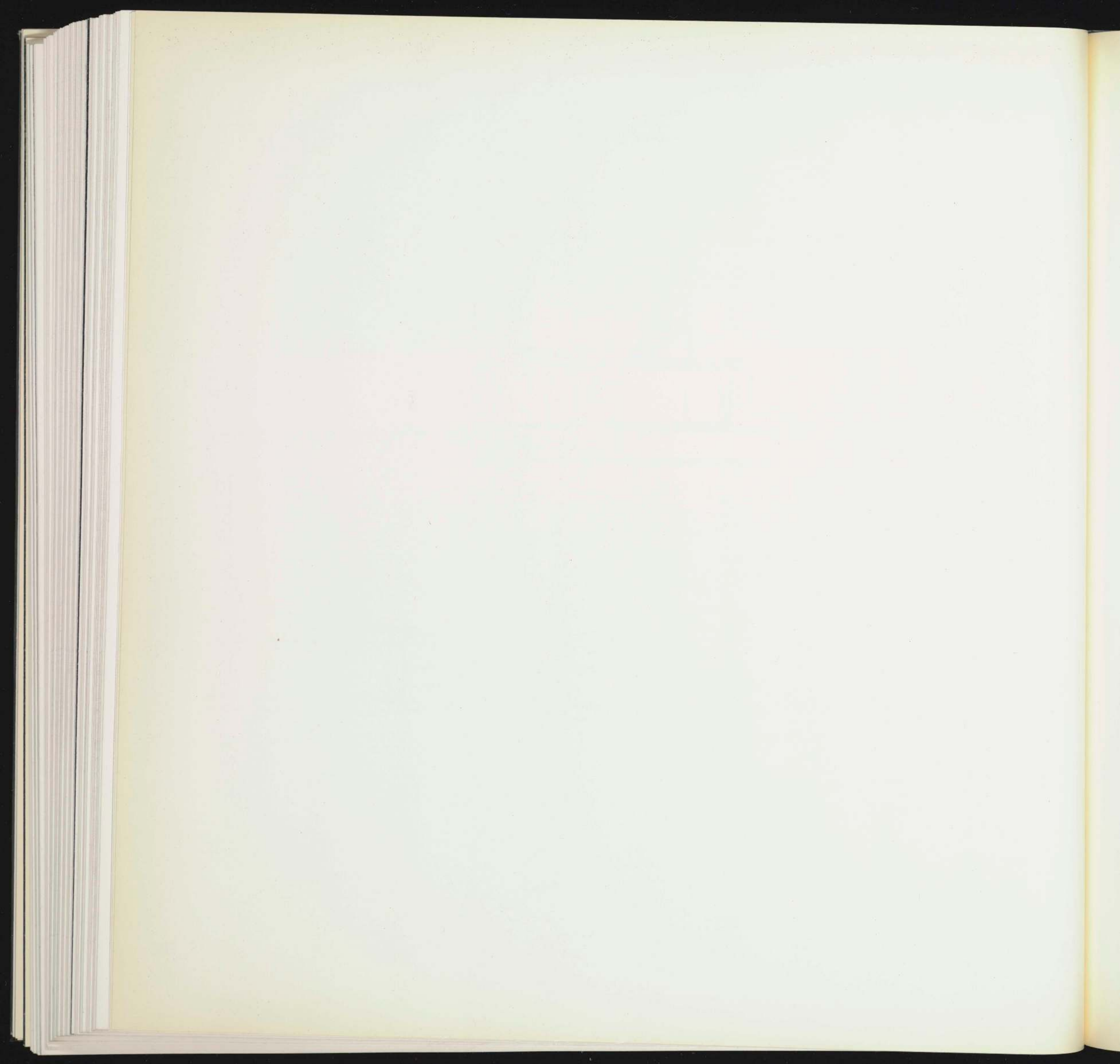

ANALYSIS PROBLEM. A work by one of the major architects of the twentieth century is selected and analyzed in depth. The analysis is done either by a single individual or by a team of students. The work is analyzed and viewed from many different angles; in this way the complexities and overlays of architectural thought and fact are revealed. The student begins to understand and realize how much really goes into the making of a significant piece of architecture. He dissects the work and reassembles it; he begins to discover the differences and similarities among the major works. He finds that some works defy dissection; that they have a tendency not to be separable into parts, and consequently the meaning of organic takes on a significance. In the search, things are discovered that perhaps the creator of the work had not even intended. Through the investigation, the student reveals his own architectural thought to himself on a more critical plane; he even invents within the analysis. At first the ego is overwhelmed by a thorough analysis of another's work—a period of adjustment becomes necessary before the start of one's own creative work—but once the impact is received and absorbed, one's new work becomes filled on many levels. The analysis problem is one of re-creation.

John Hejduk

ANALYTICAL MODEL AND DRAWINGS: THE CHURCH AT FIRMINY-VERT/JAMES E. MILLER, PETER
SALTINI.

R

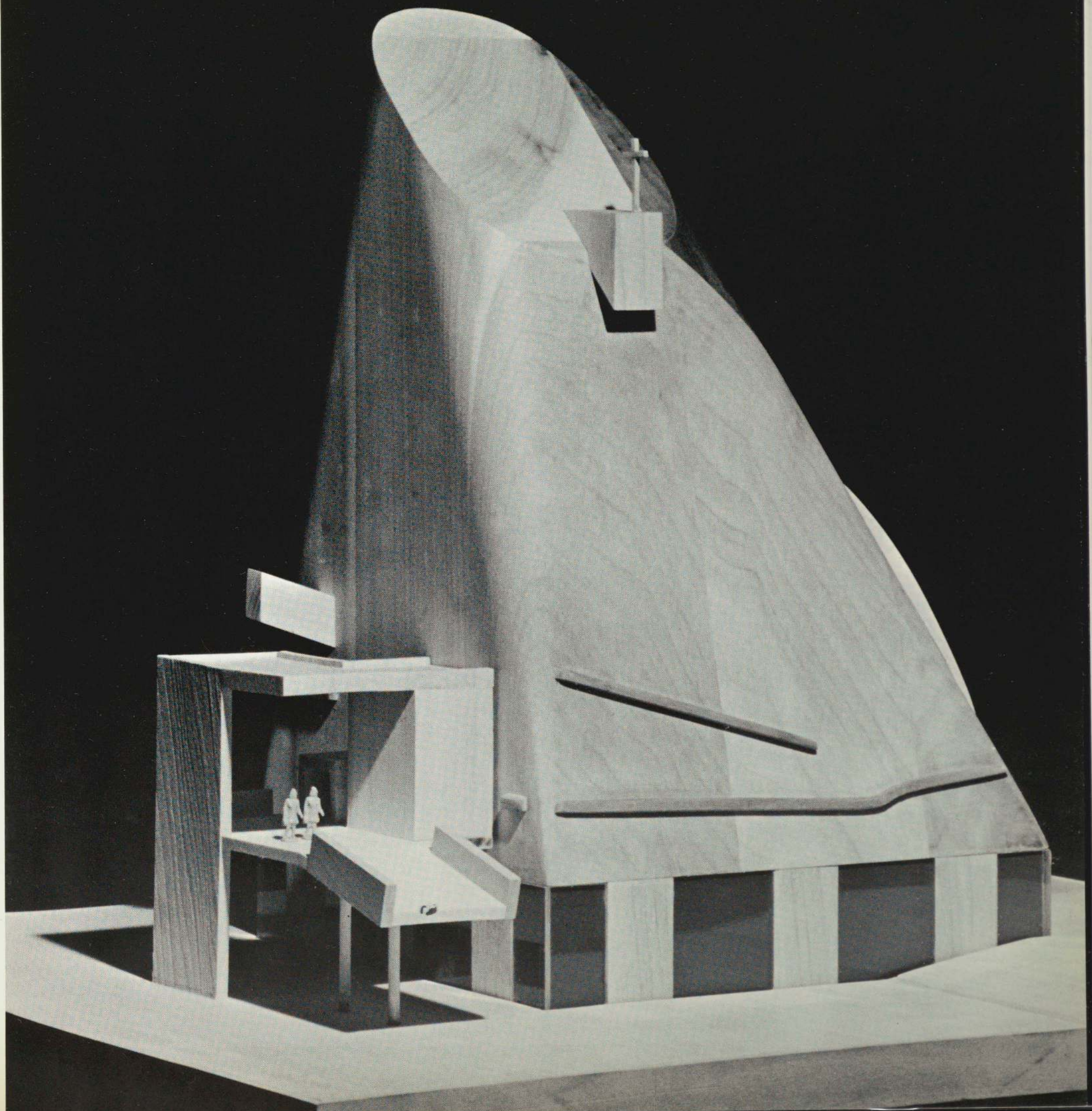

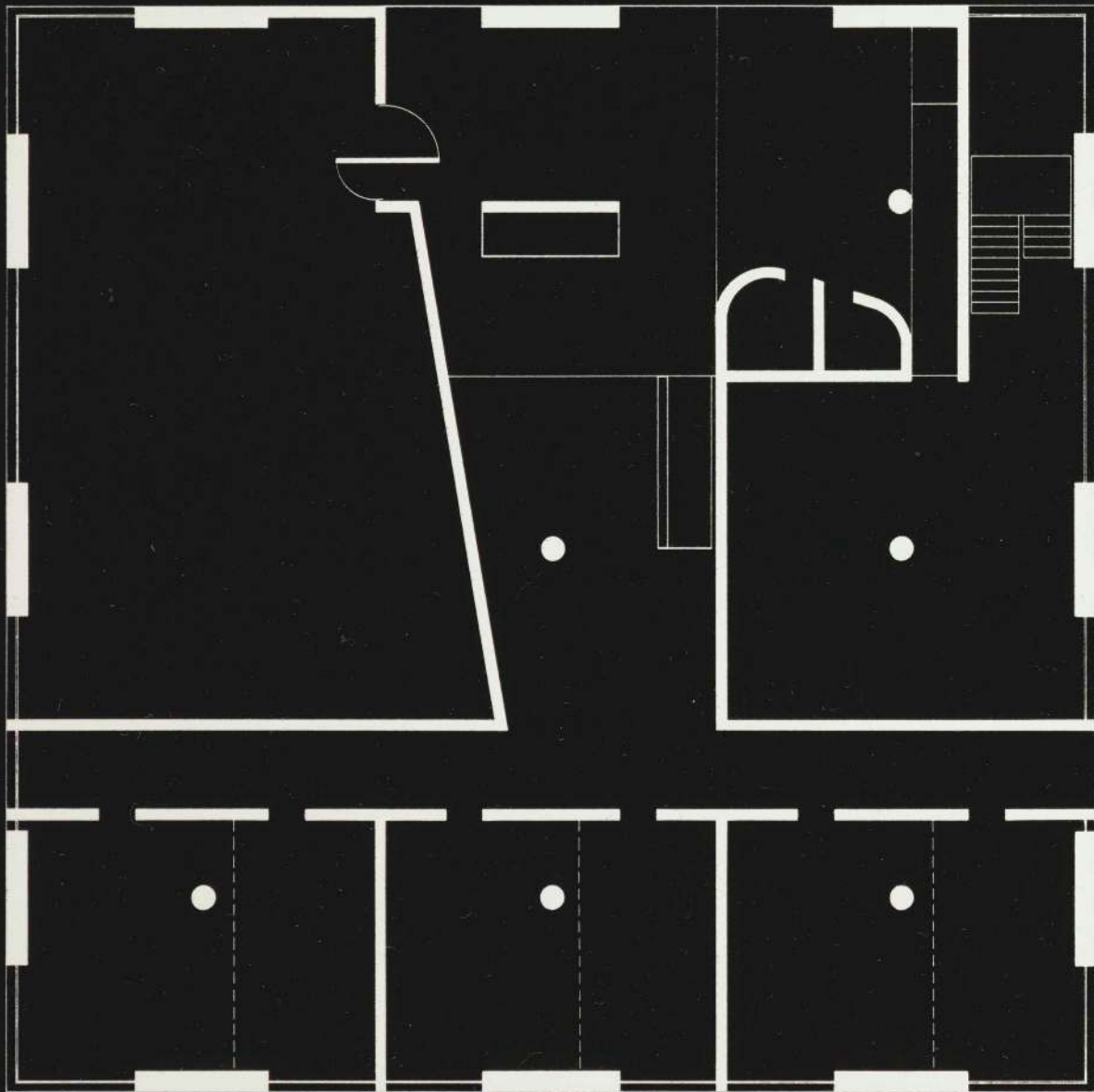



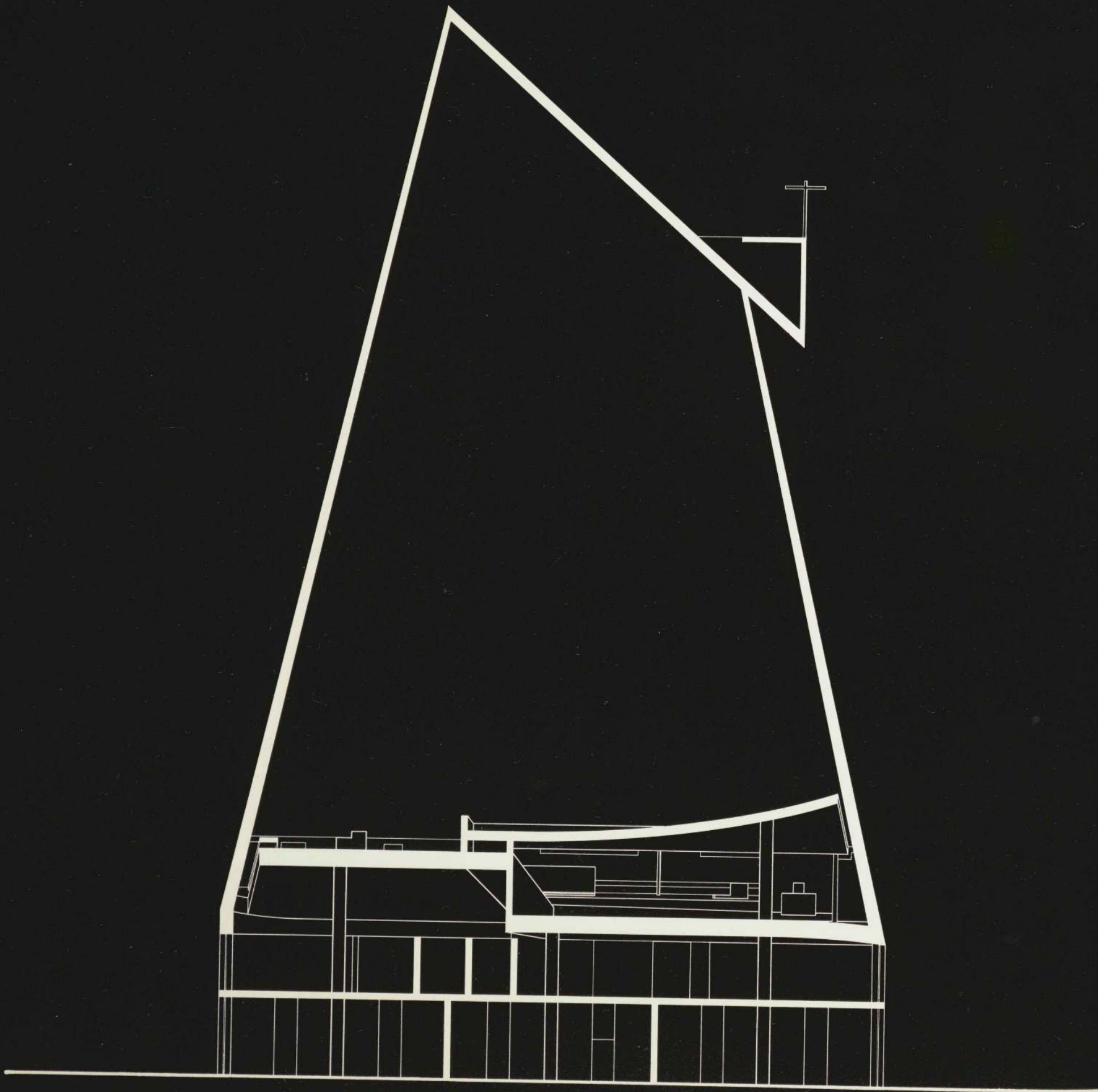













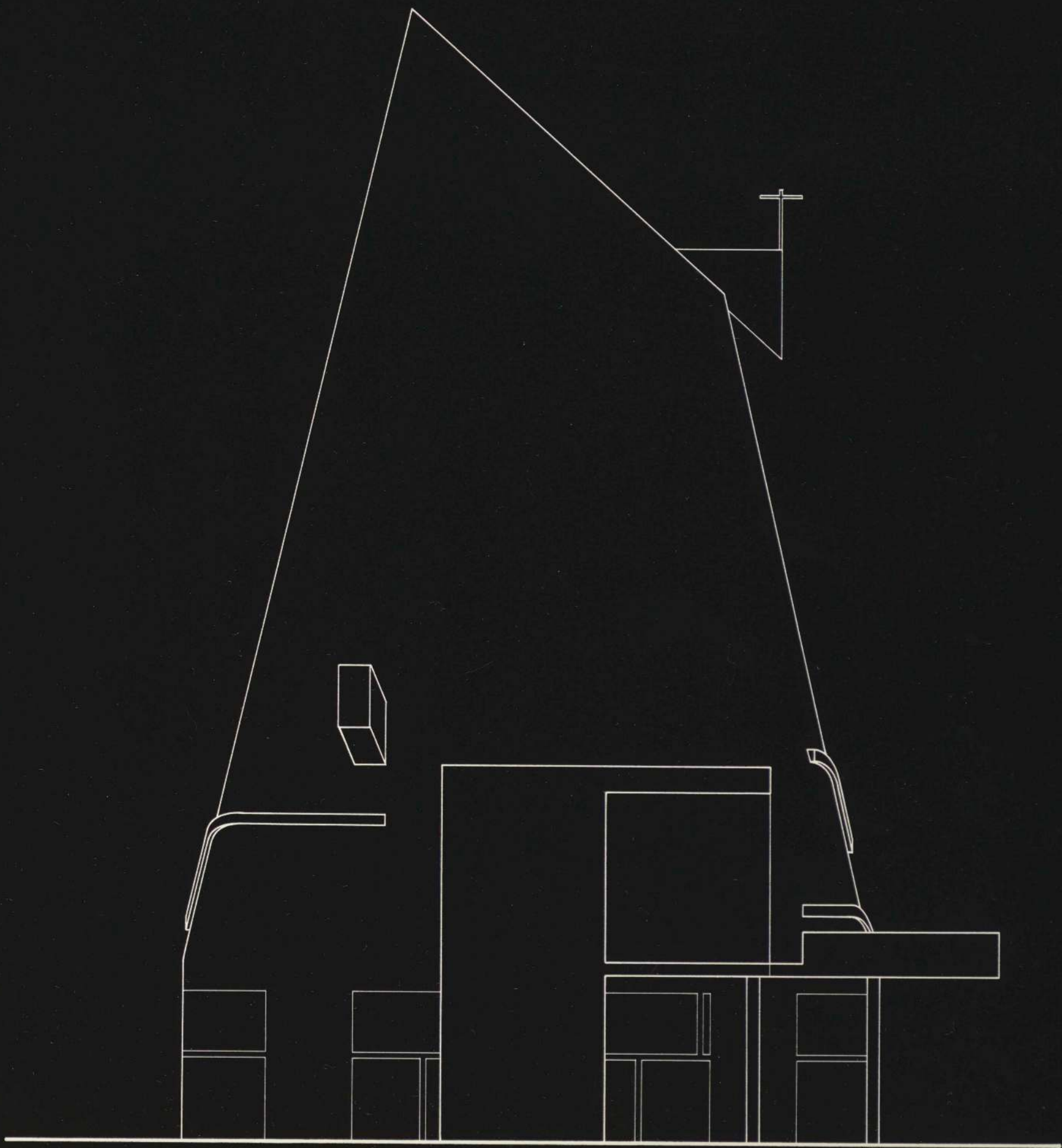



INDEPENDENT THESES. Up to this point, the projects illustrated in this book represent direct responses to certain invented pedagogical problems—problems designed to act as catalysts; to provoke cerebral reactions; to challenge creative abilities; in short, to activate the educational process. At a certain point however, for certain students, such catalysts cease to be necessary. A self-sustaining involvement with architecture—an involvement both energetic and profound—is attained. Independent ideas, capable of engaging the mind and sustaining the educational process, begin to emerge. Pedagogical inventions may now be put aside. Independent theses take shape.

HOUSING, NEW YORK CITY/MANUEL I. FERNANDEZ. Flexible systems permit apartment expansion through any number of floors and bays—thus the total number of units can vary to a maximum of 252 (100 families per acre) during the life of the building. All units are accessible by corridors that face a community space. Each unit has at least one through-floor, and terraces facing both a city street and the community space. Underground parking is provided. The structural system utilizes a permanent, pre-cast concrete frame and movable pre-cast concrete floor planks (to permit vertical expansion). The community space is enclosed by a prefabricated aluminum and plastic space frame. The mechanical system includes heat pumps at the exterior window wall, and plumbing and electrical chases as well as kitchen and bathroom exhausts at the columns. The air supply for the community space is provided at the foot of the space-frame, with air returns at various locations on the ground floor. Air exhaust fans are at the top of the space-frame. Fin-tube heating is specified under the entire area of the space-frame.

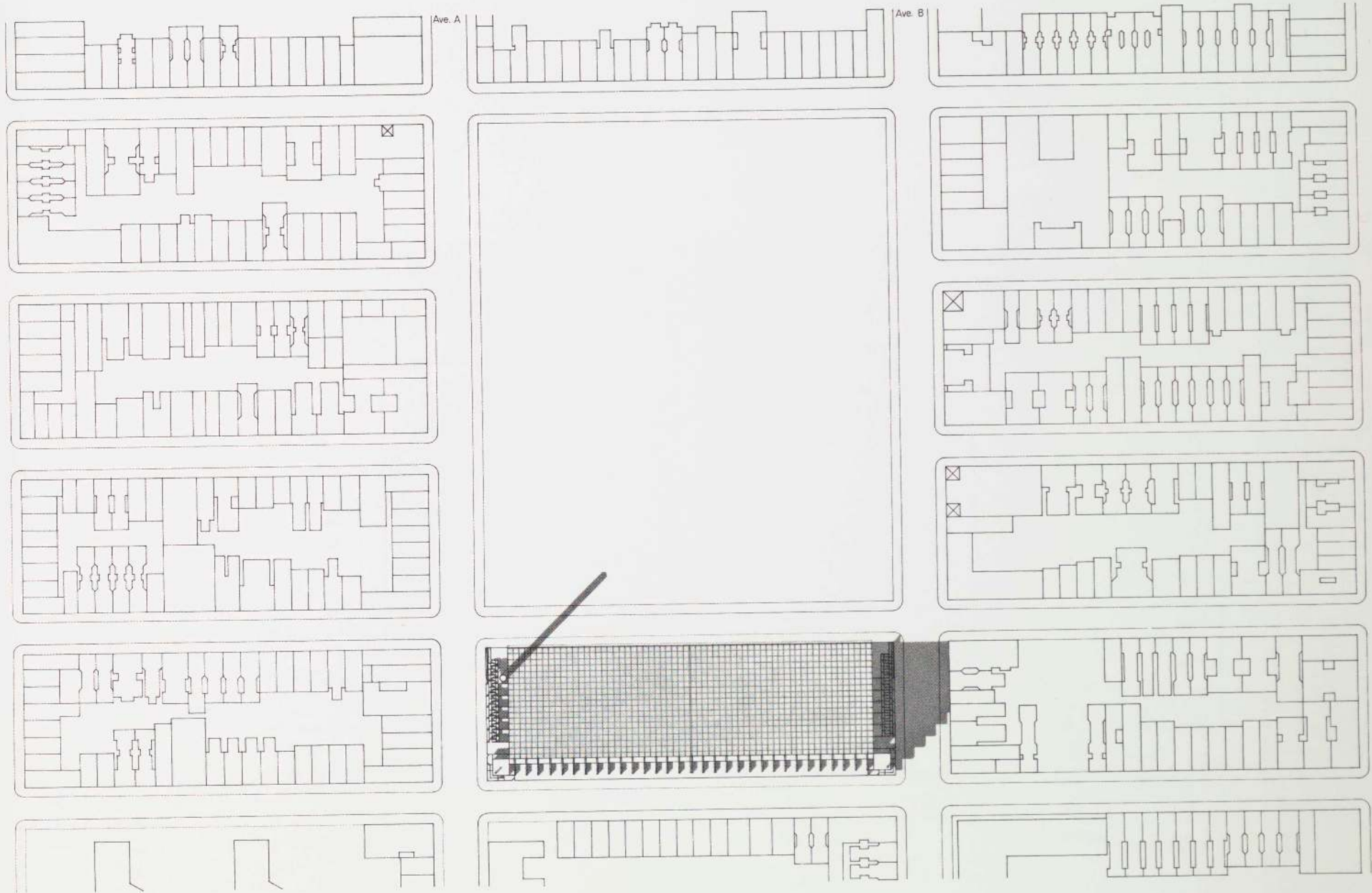

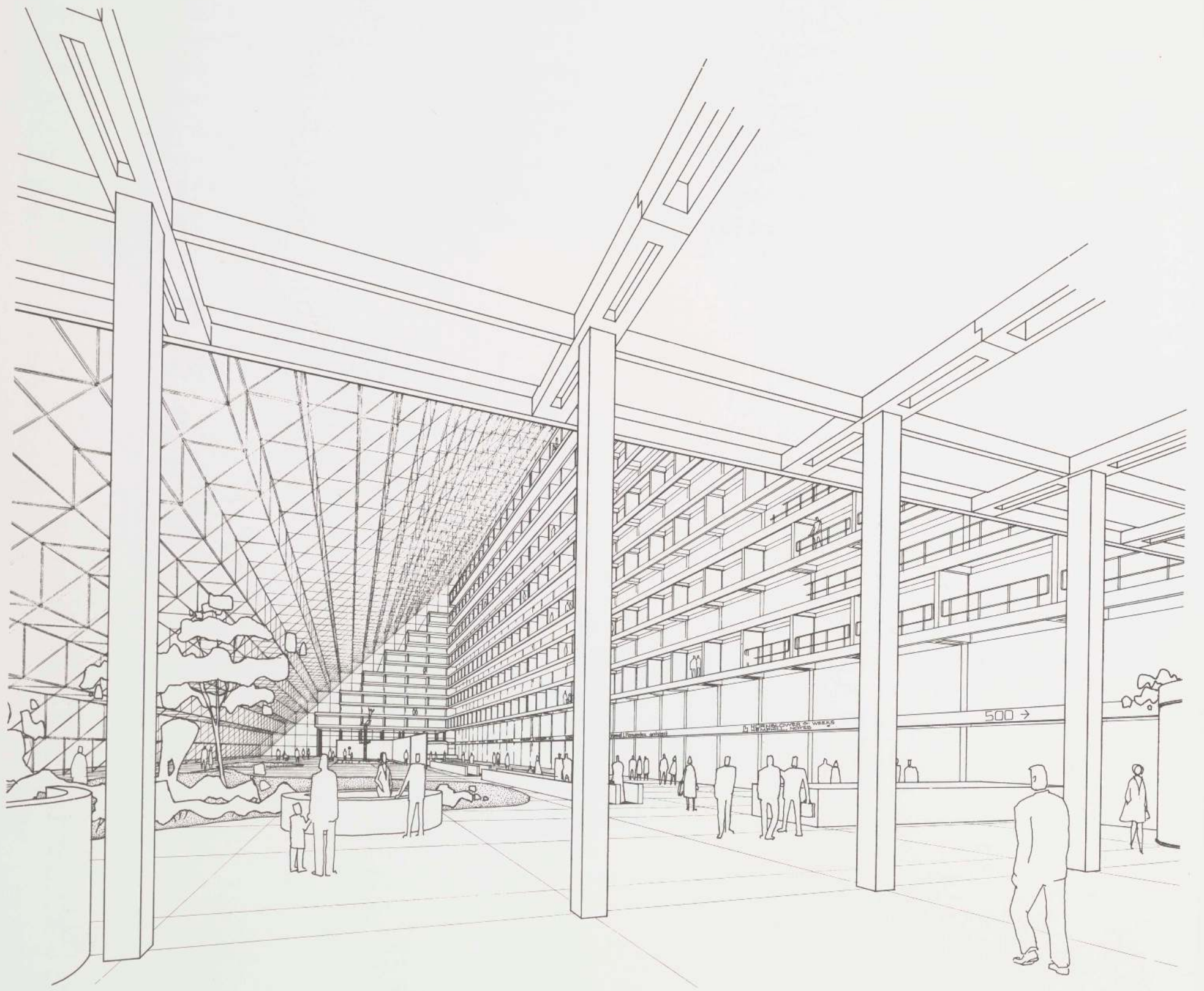

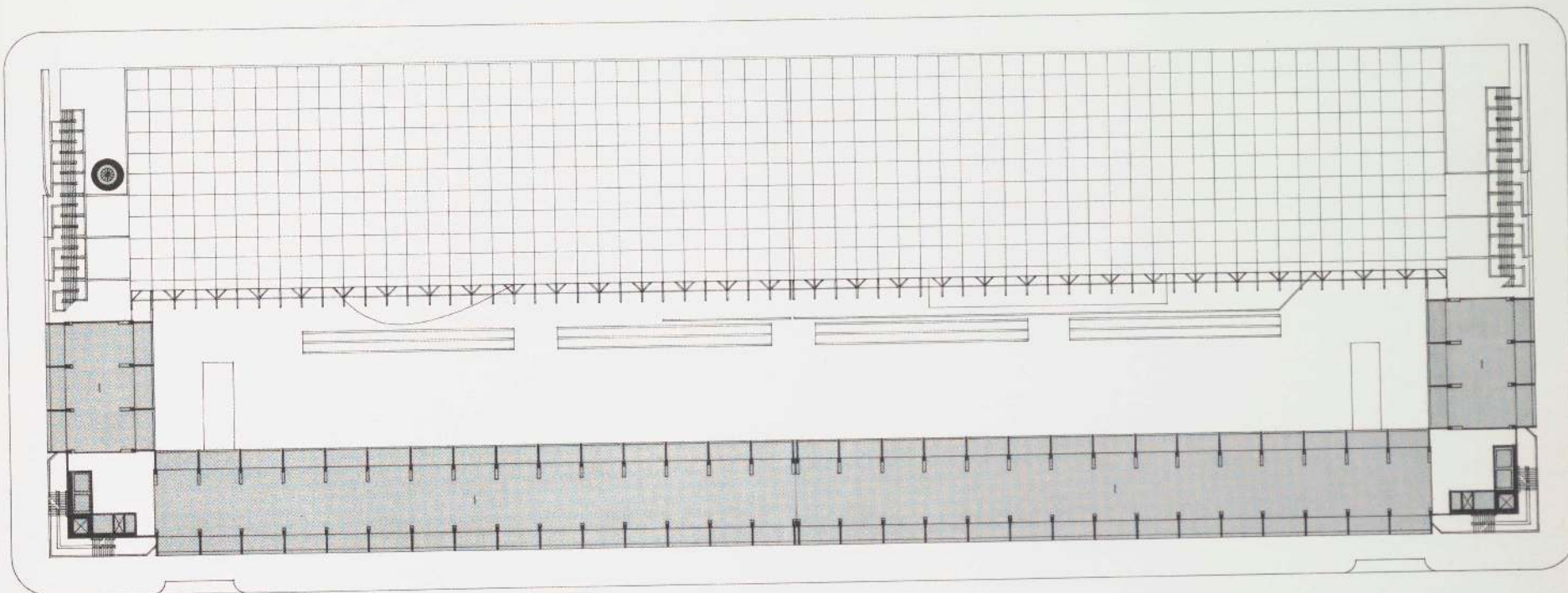

Ninth Floor Plan

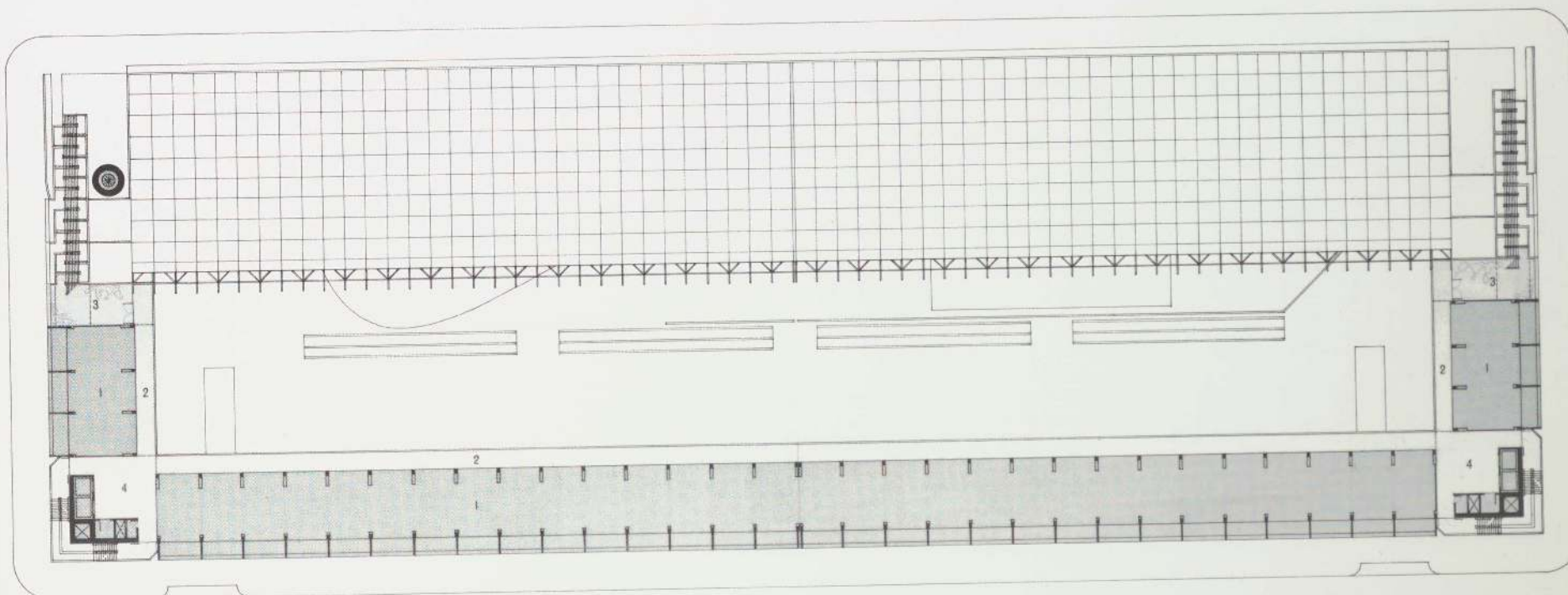

Eighth Floor Plan

0' 17"

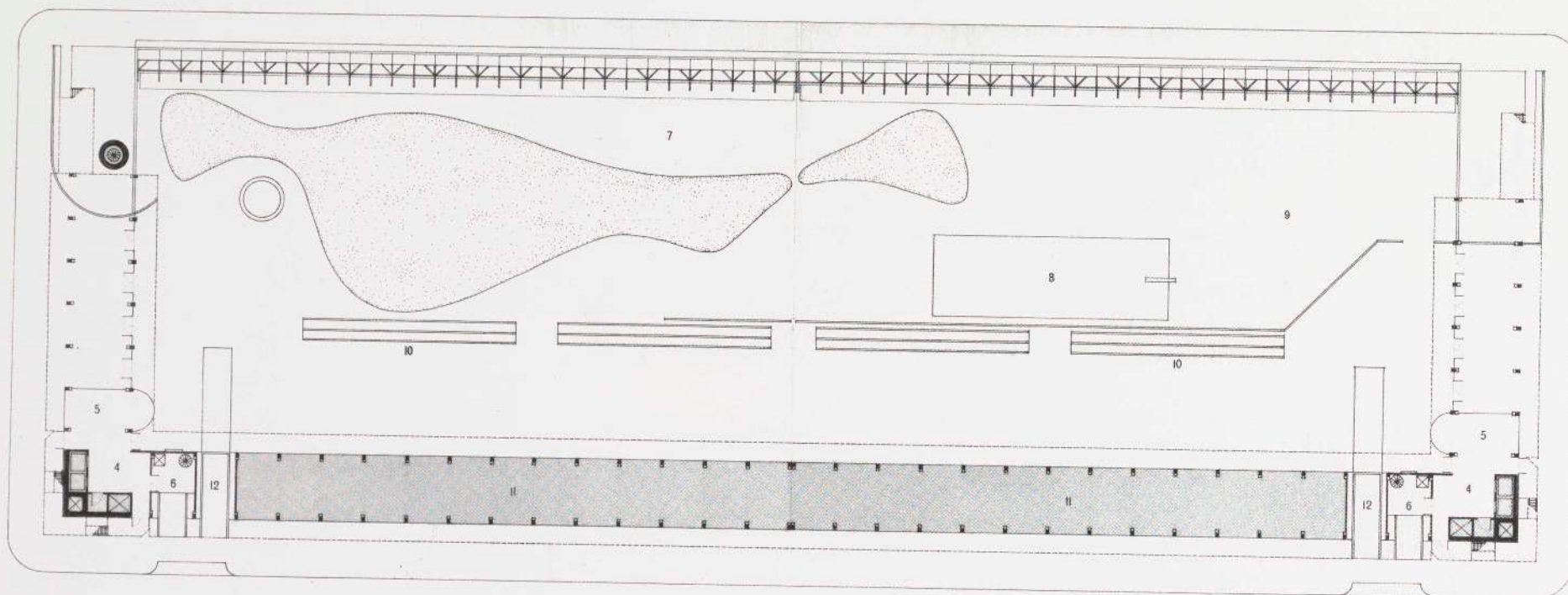

Ground Floor Plan

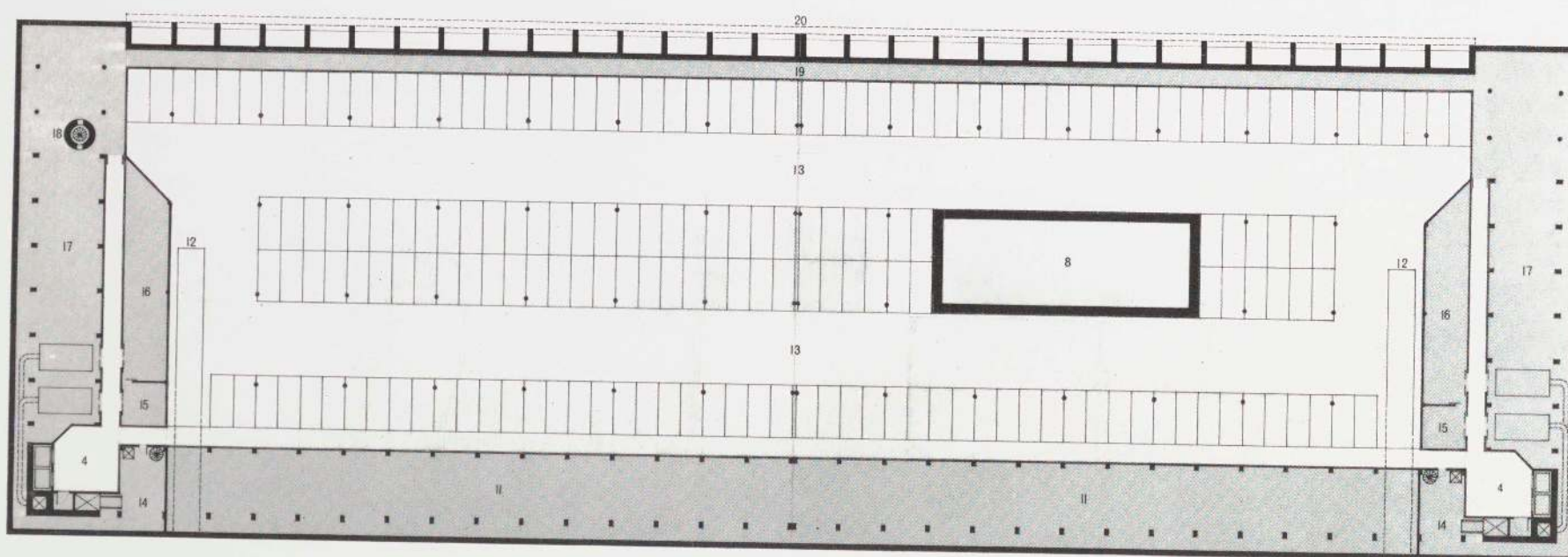

Basement Plan

0' 17'

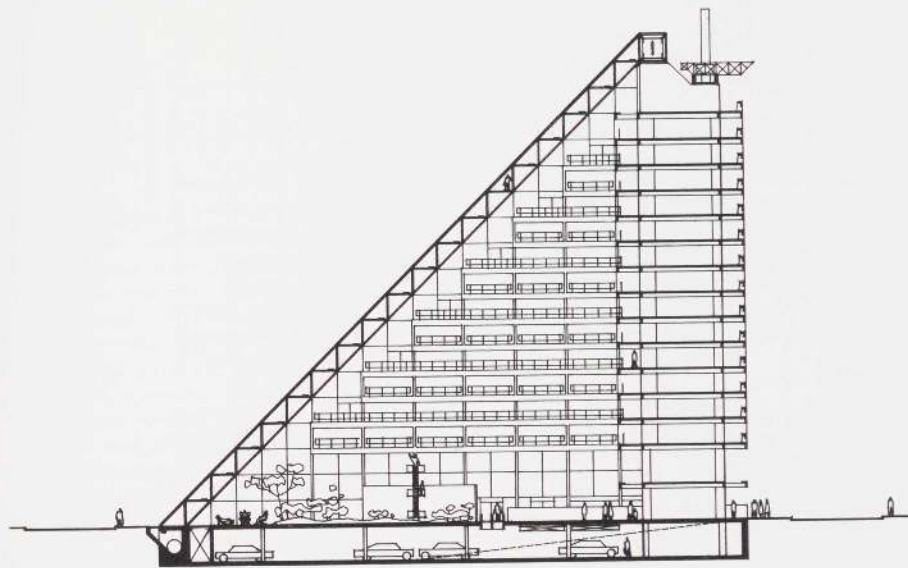

Transverse Section

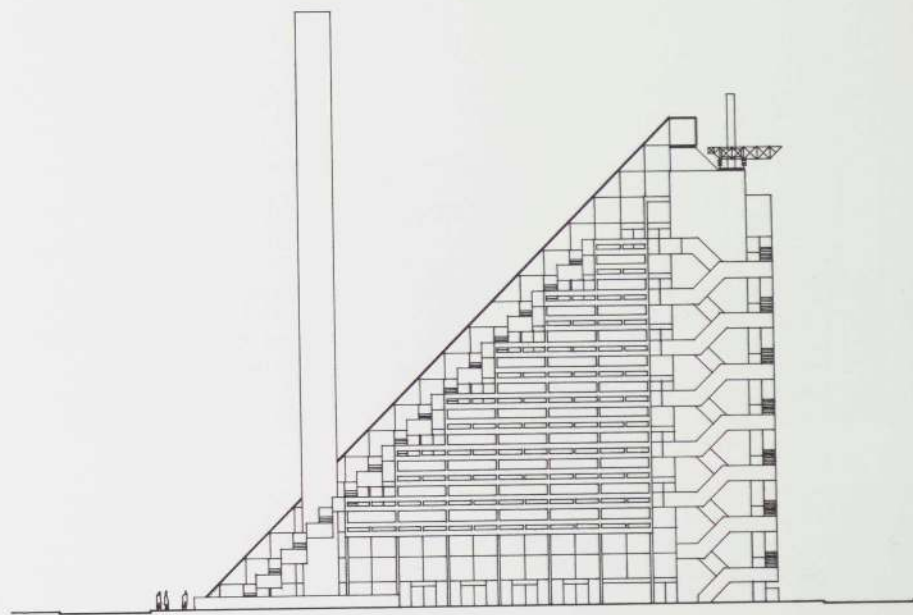

West Elevation

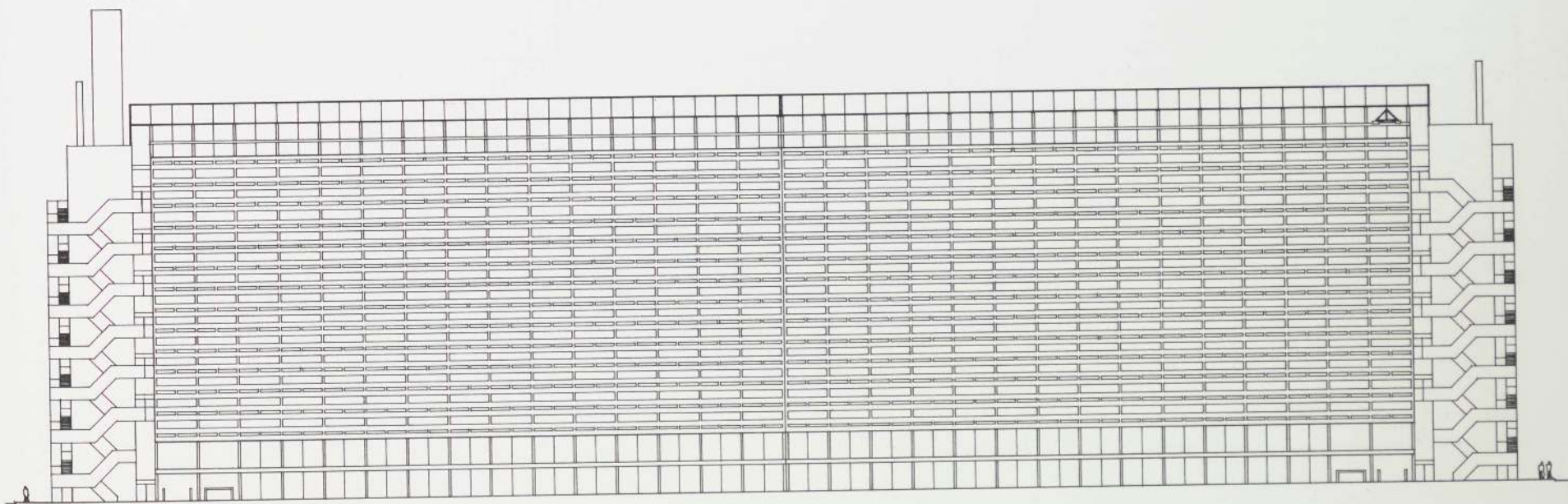

South Elevation

0' 17"

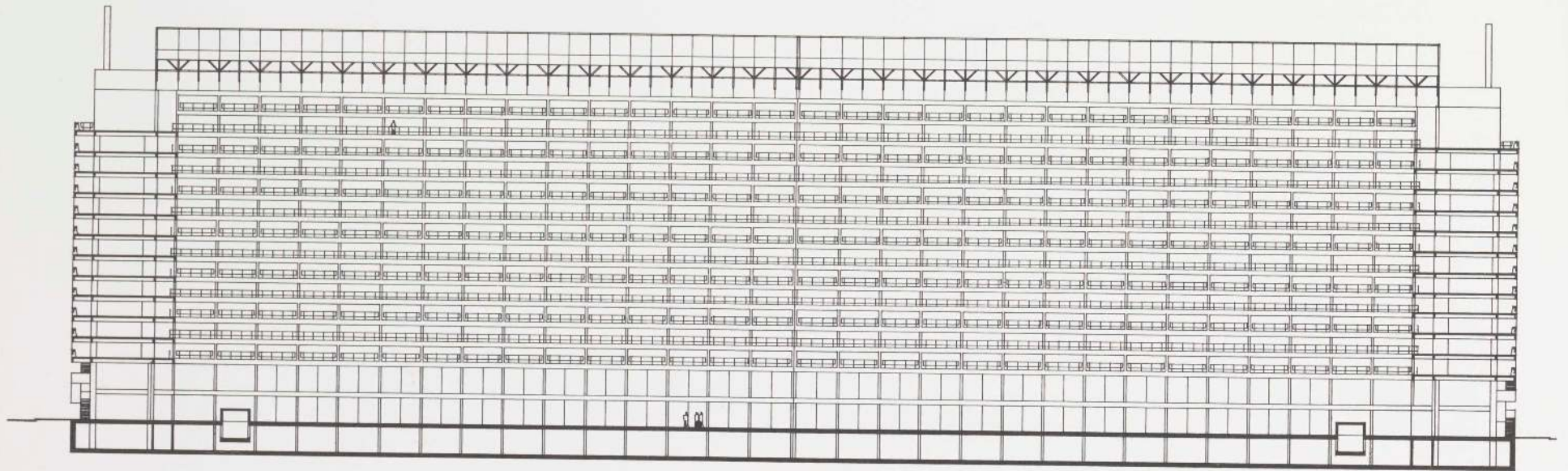

Longitudinal Section

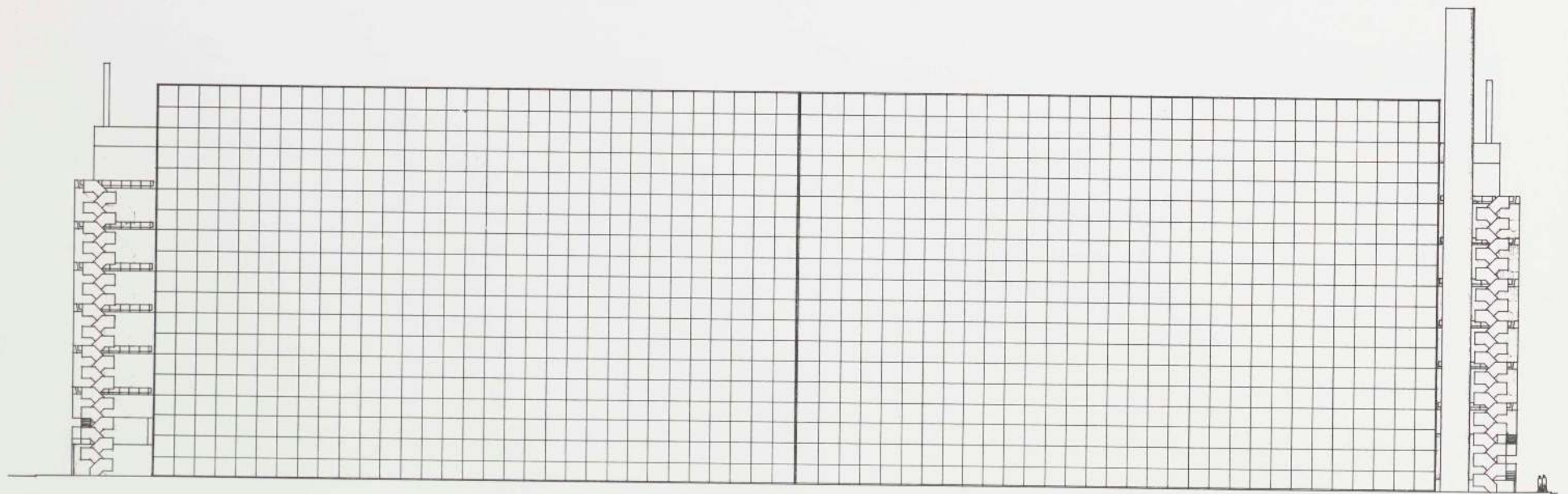

North Elevation

0' 17'

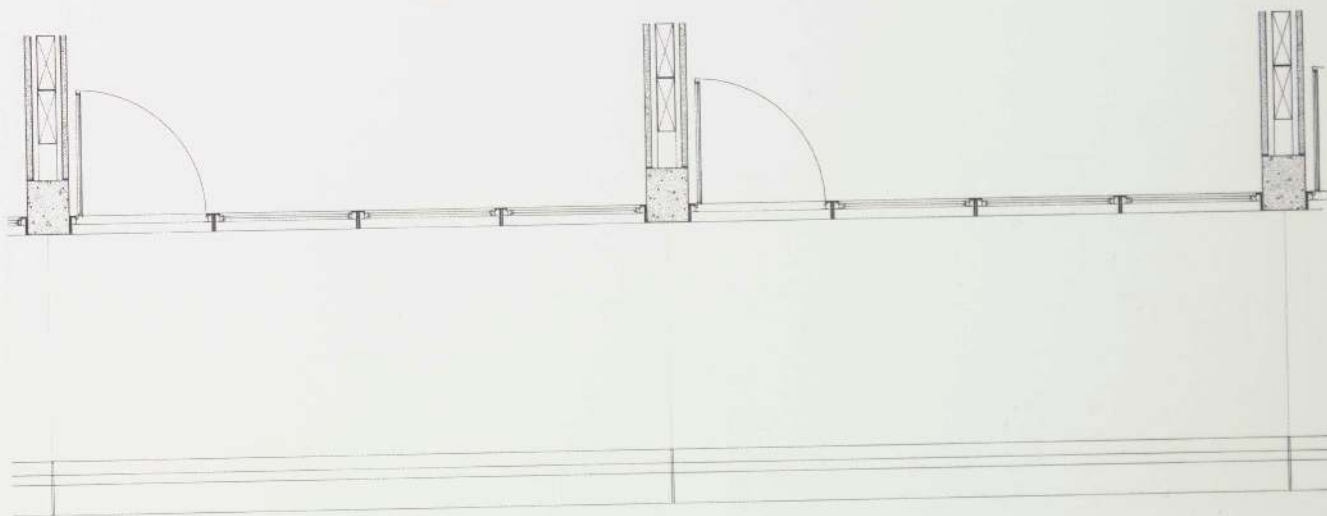
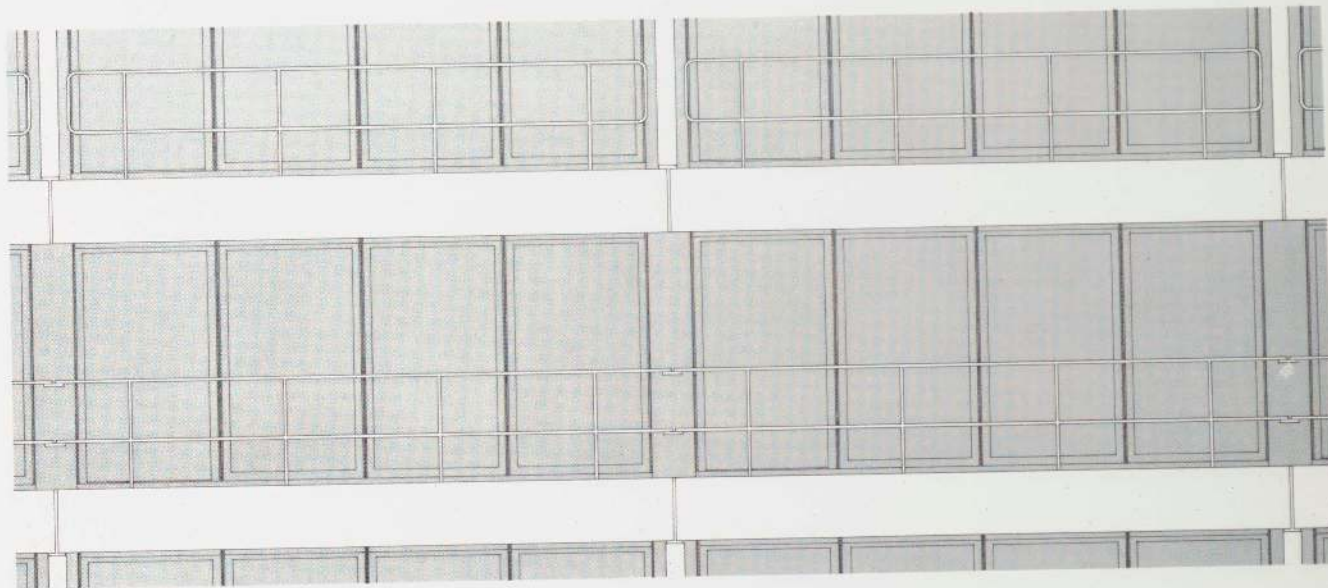
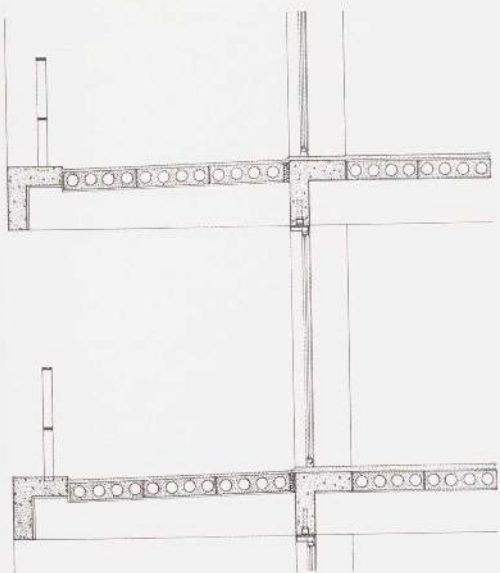

Interior Façade Details



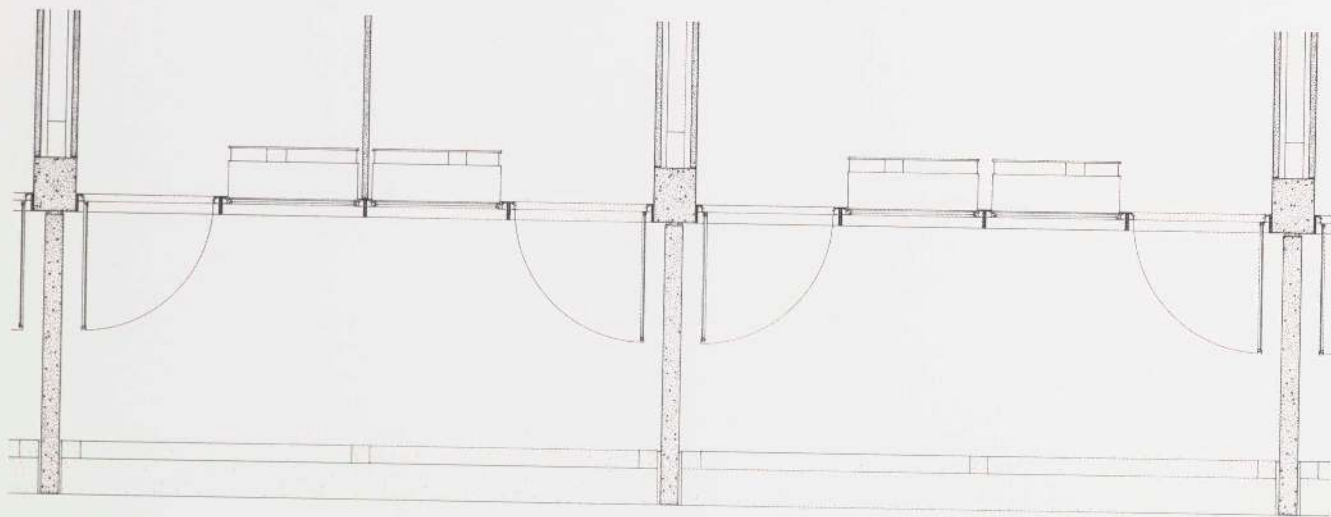
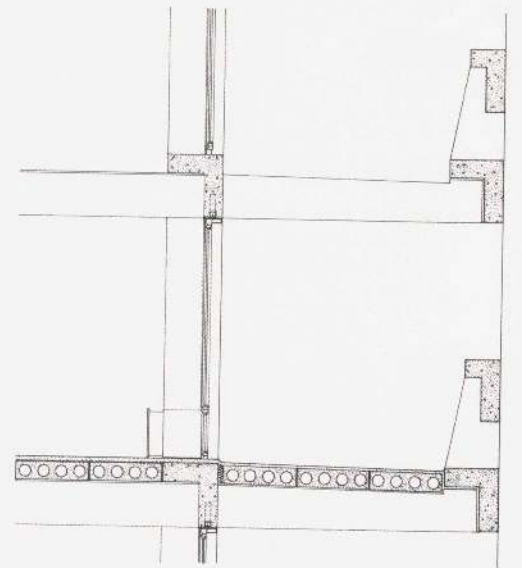
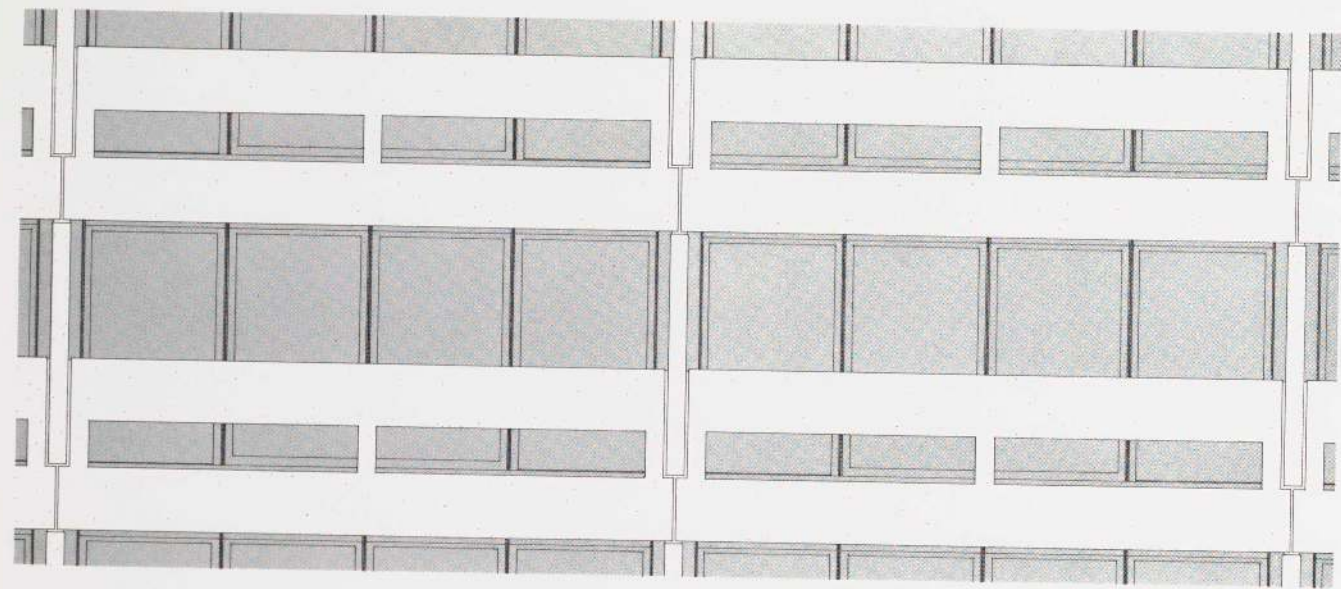

Exterior Façade Details



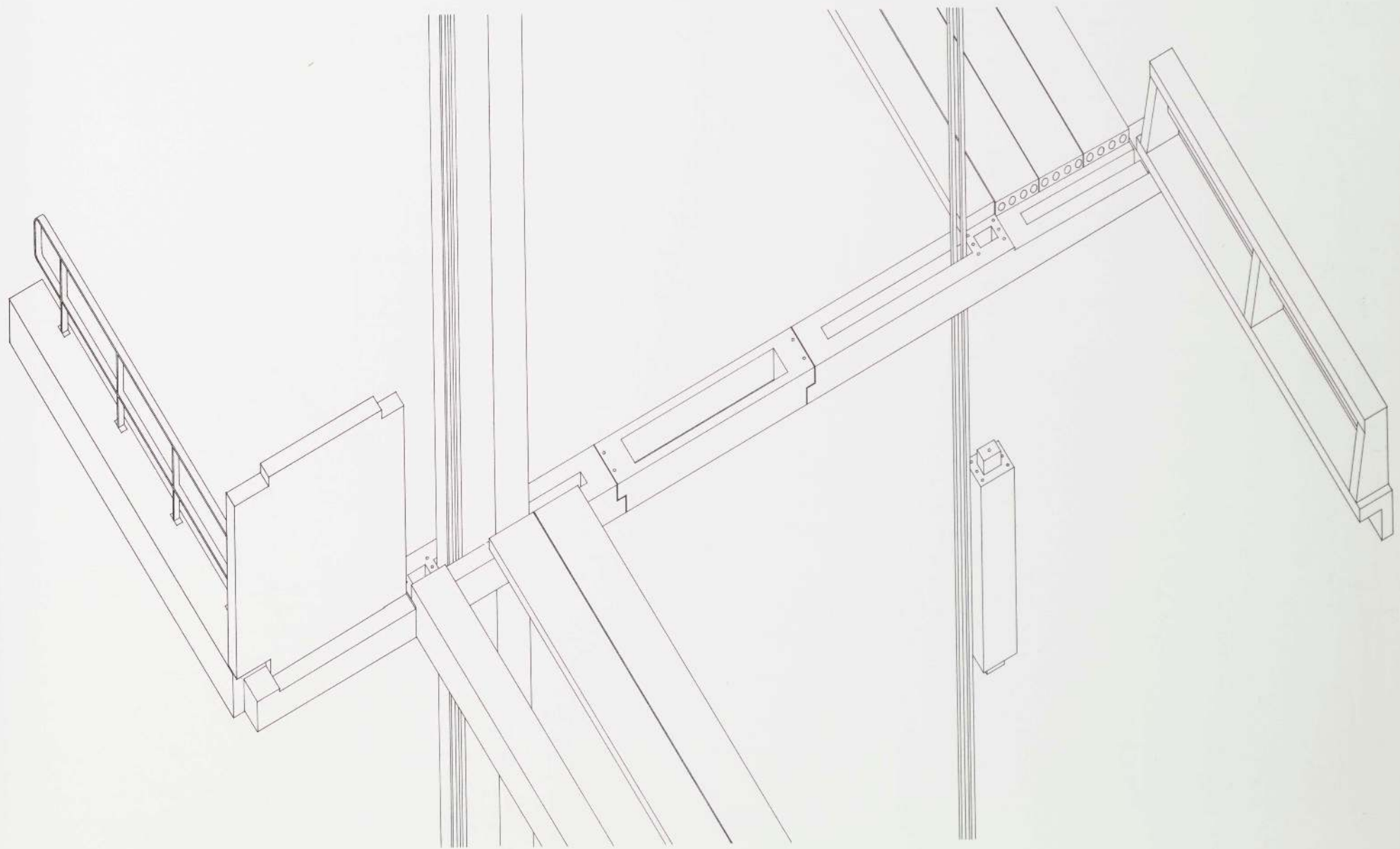

Structural and Mechanical Systems



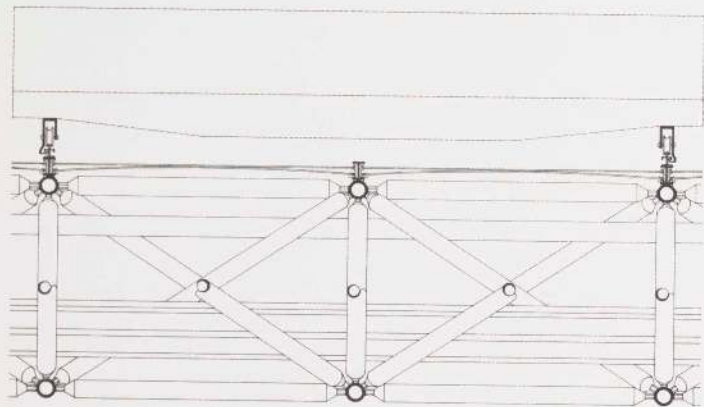

A-A

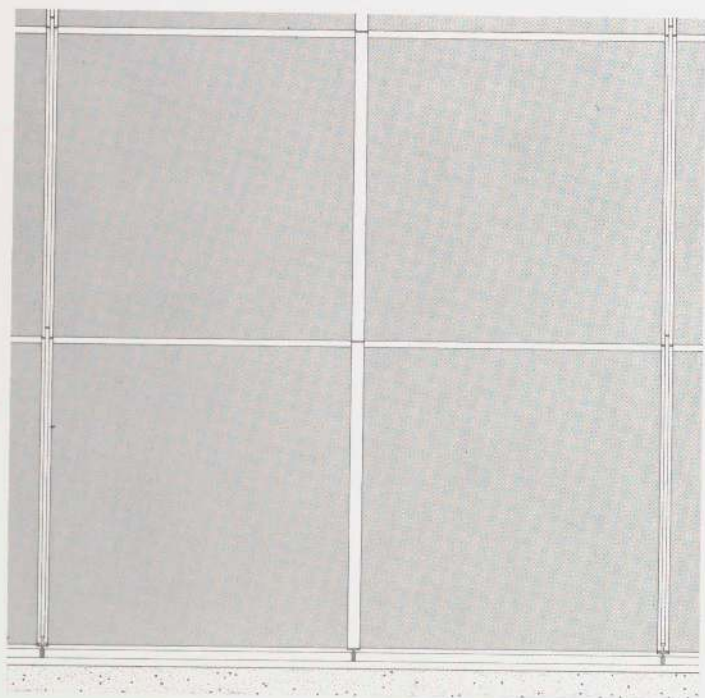

Space Frame Details

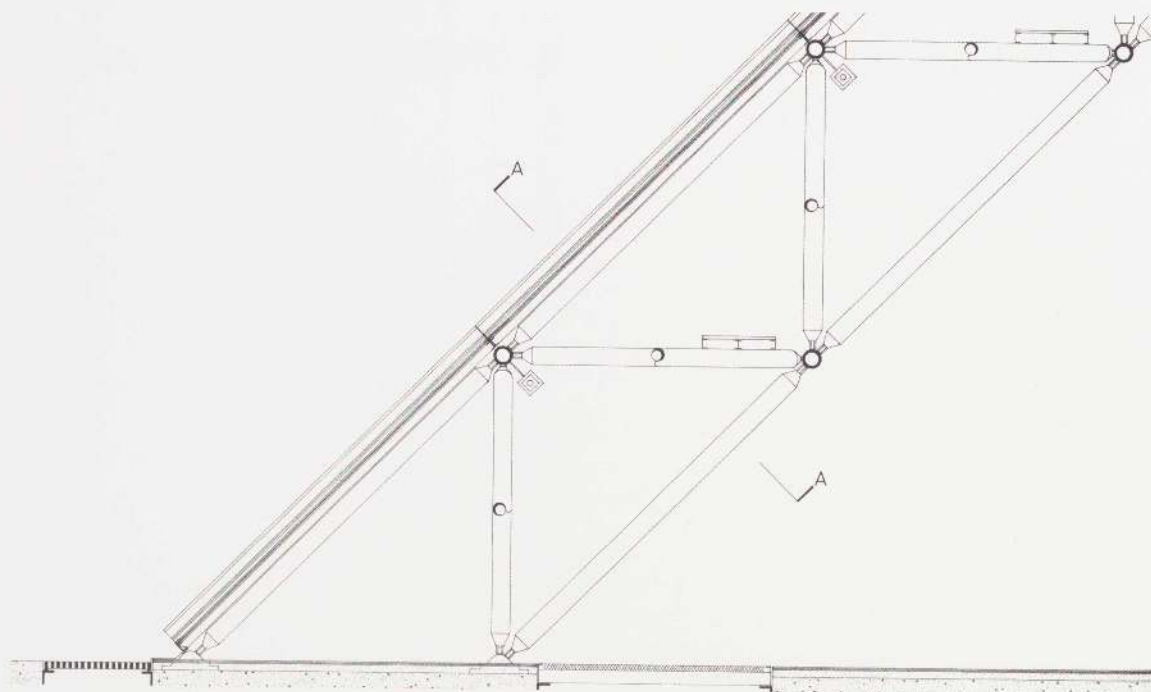

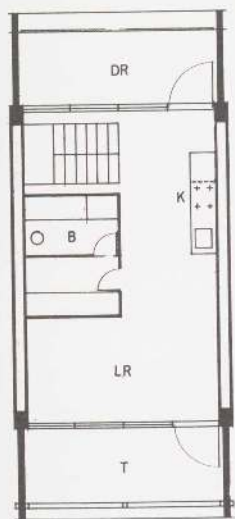

0 BR

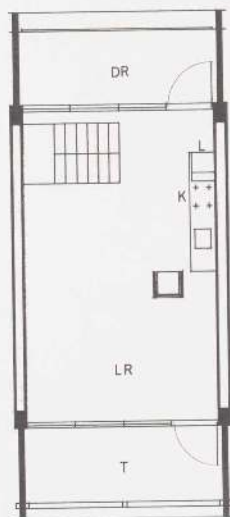

1 BR

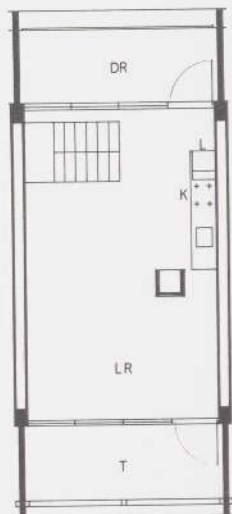

2 BR

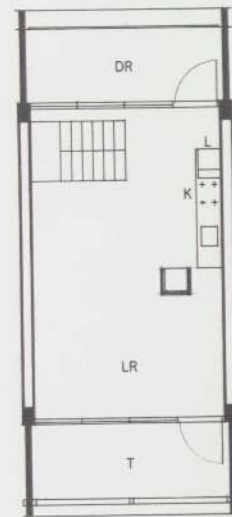

3 BR

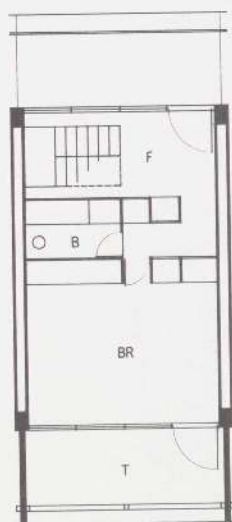
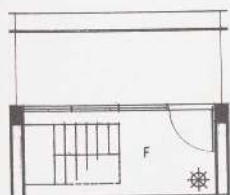

Standard Duplex Units



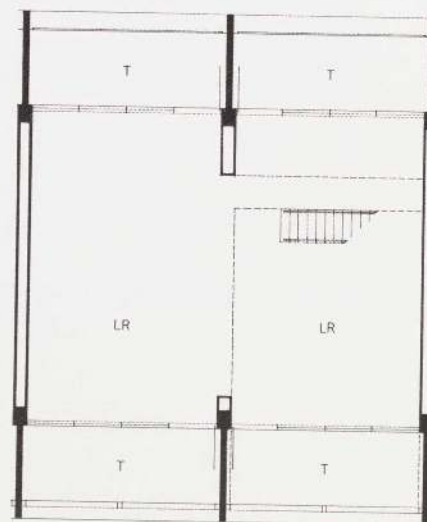
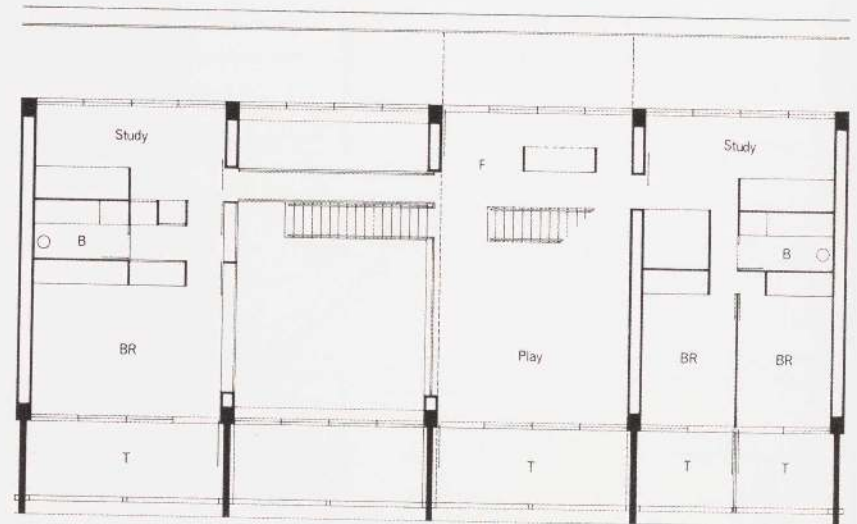
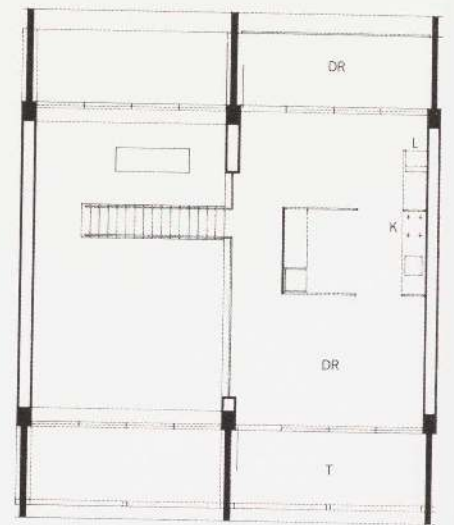
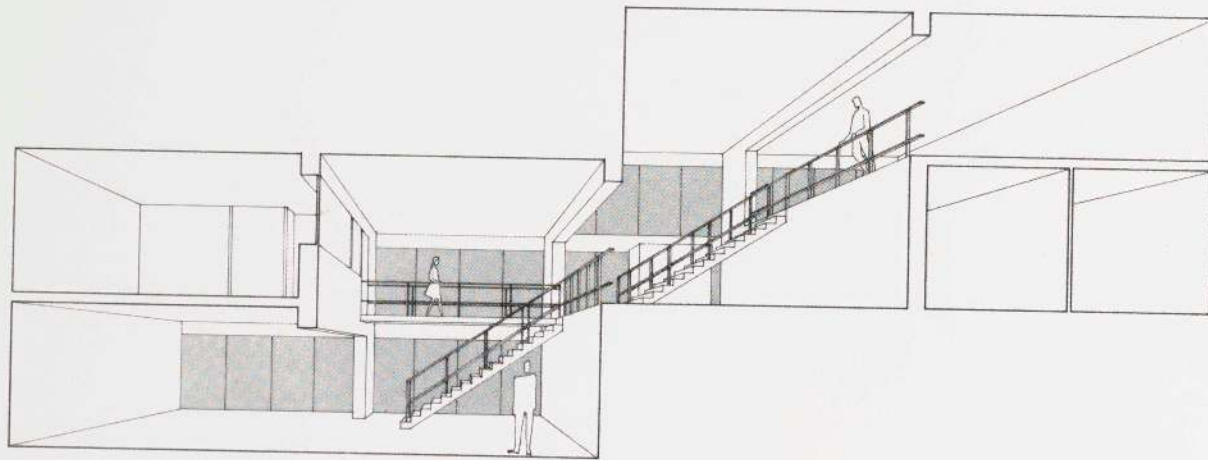

Special Unit that Illustrates Flexibility of Systems



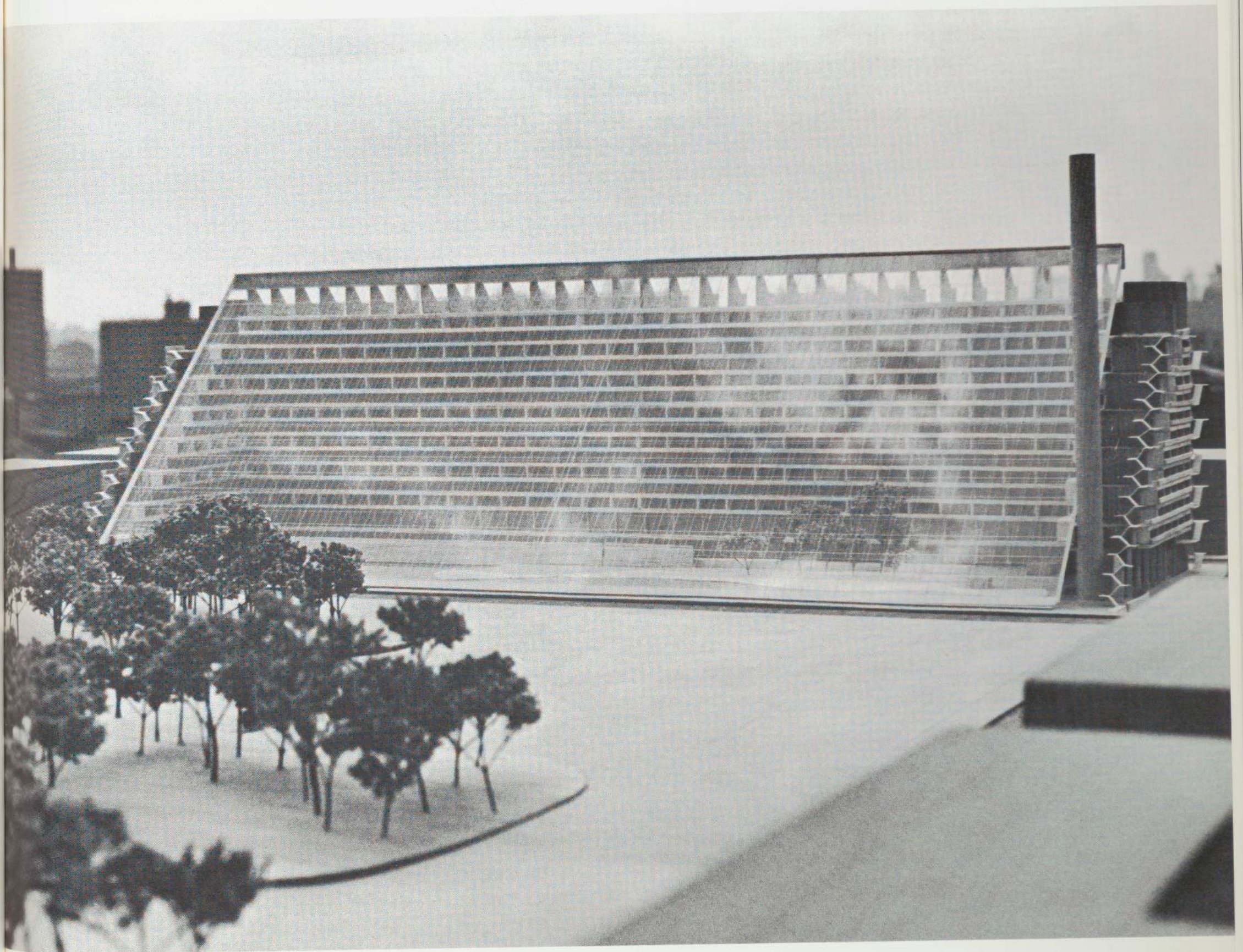

NARCOTICS CENTER/PETER LUNG. This thesis concerns the design of a narcotics center located within a city block. A specific site was purposely avoided, because one chose to work instead with a particular 'field condition'. This condition being a 50' x 100' lot occupying a complete cut through a city block, so that it would be confined on the north and south sides by a 50' street frontage, and on the east and west by residential units five storeys high and 50' in depth from the north and south boundaries. For programmatic reasons one chose to differentiate both physically and structurally the two poles of the building—thus creating what one would call a positive terminal and a negative terminal. The positive terminal of the building contains workshops on the lower two levels and sleeping areas on the upper three. The facades of this section of the building are rough masonry with incisional fenestrations. On the negative terminal of the building the ground level is the social-dining area, while the upper levels are devoted mainly to office-seminar usage. However, the facades of this portion of the building, in respect to the positive terminal, are sleek and transparent. The circulation link which joins the two terminals had to remain physically a neutral component. It incorporates the abstractions of both terminals into a single entity. One side of the link incorporates the rough masonry finish, while the other side is a glass curtain wall. The final solution was the logical result of a thought process. There was no preconception of a final form in terms of space, construction, or material. The building was pieced together much as one would assemble a collage. One has to deal with a field and a given number of elements. The success of a collage lies in the utilization of each distinct element so that it retains its uniqueness while being a very necessary part of the total image.

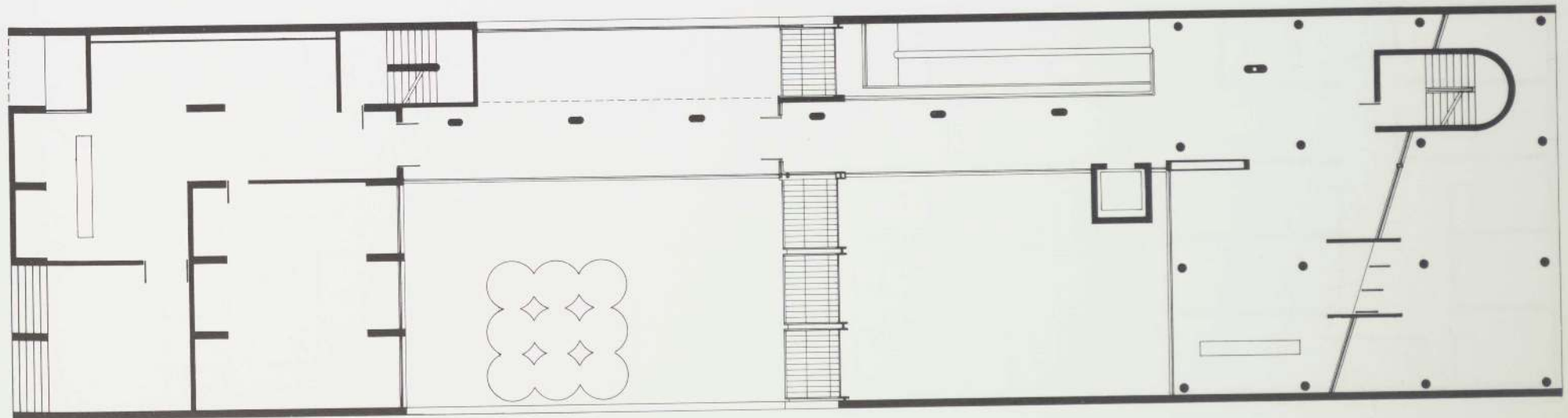
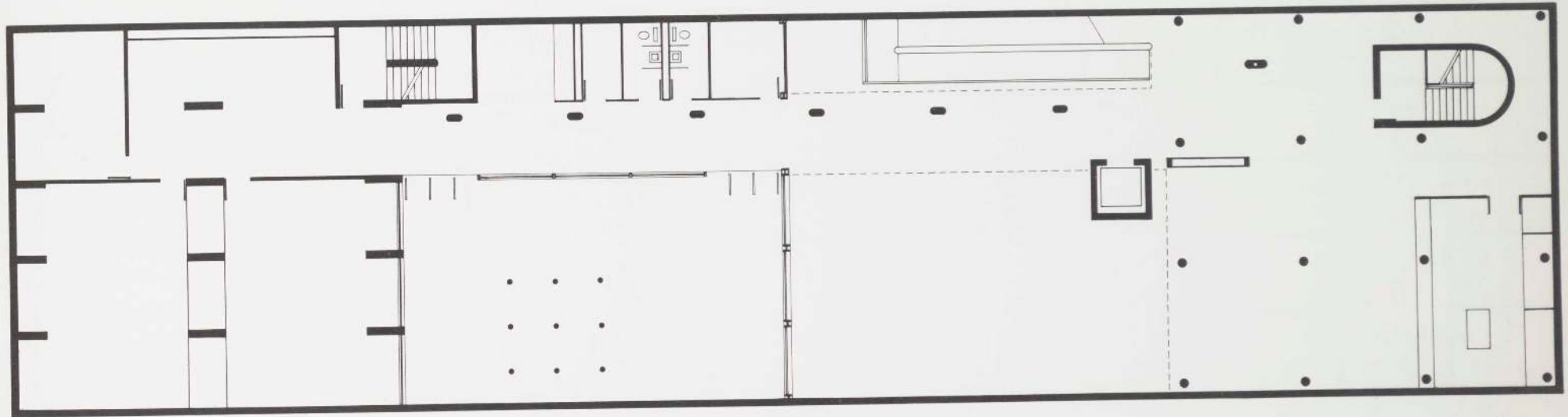

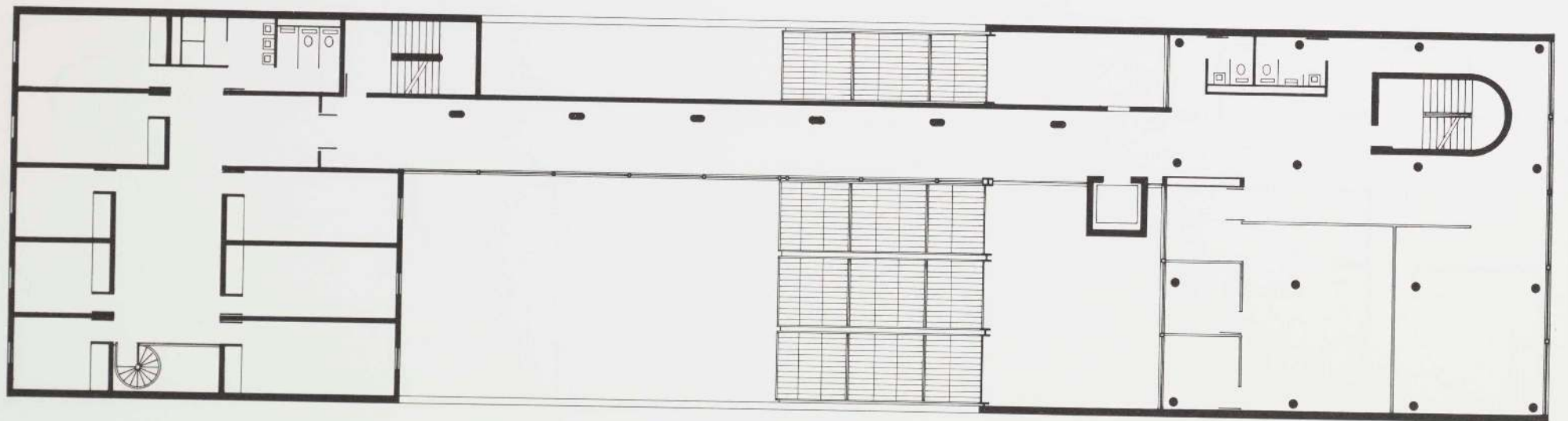
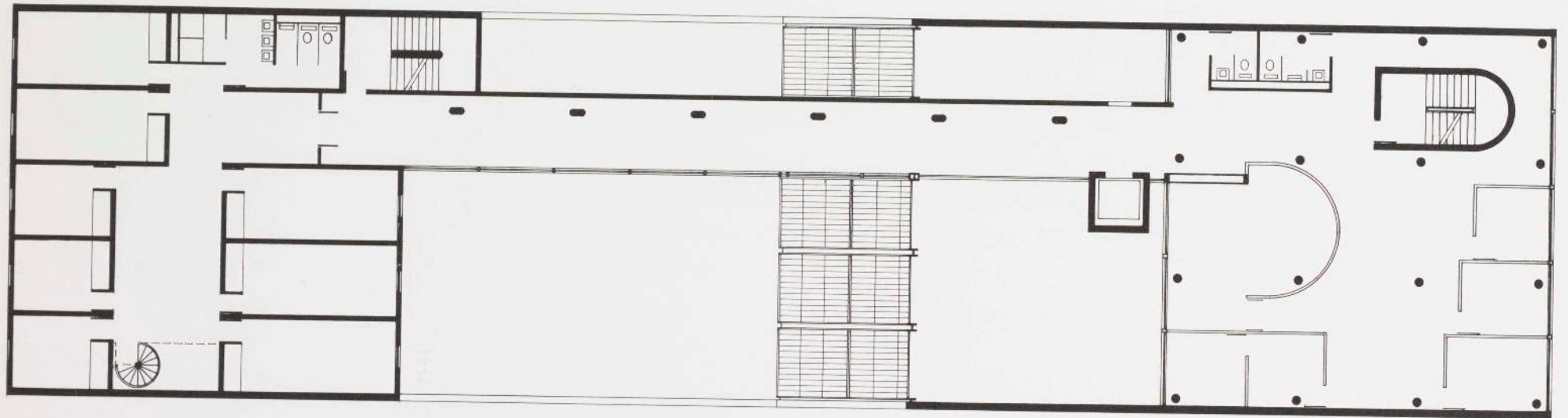

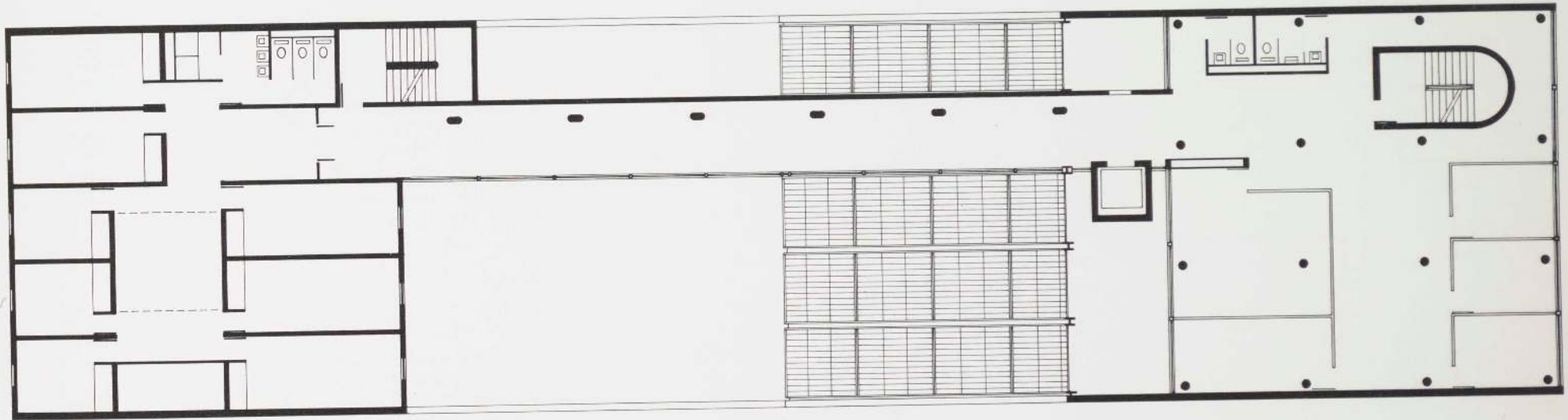

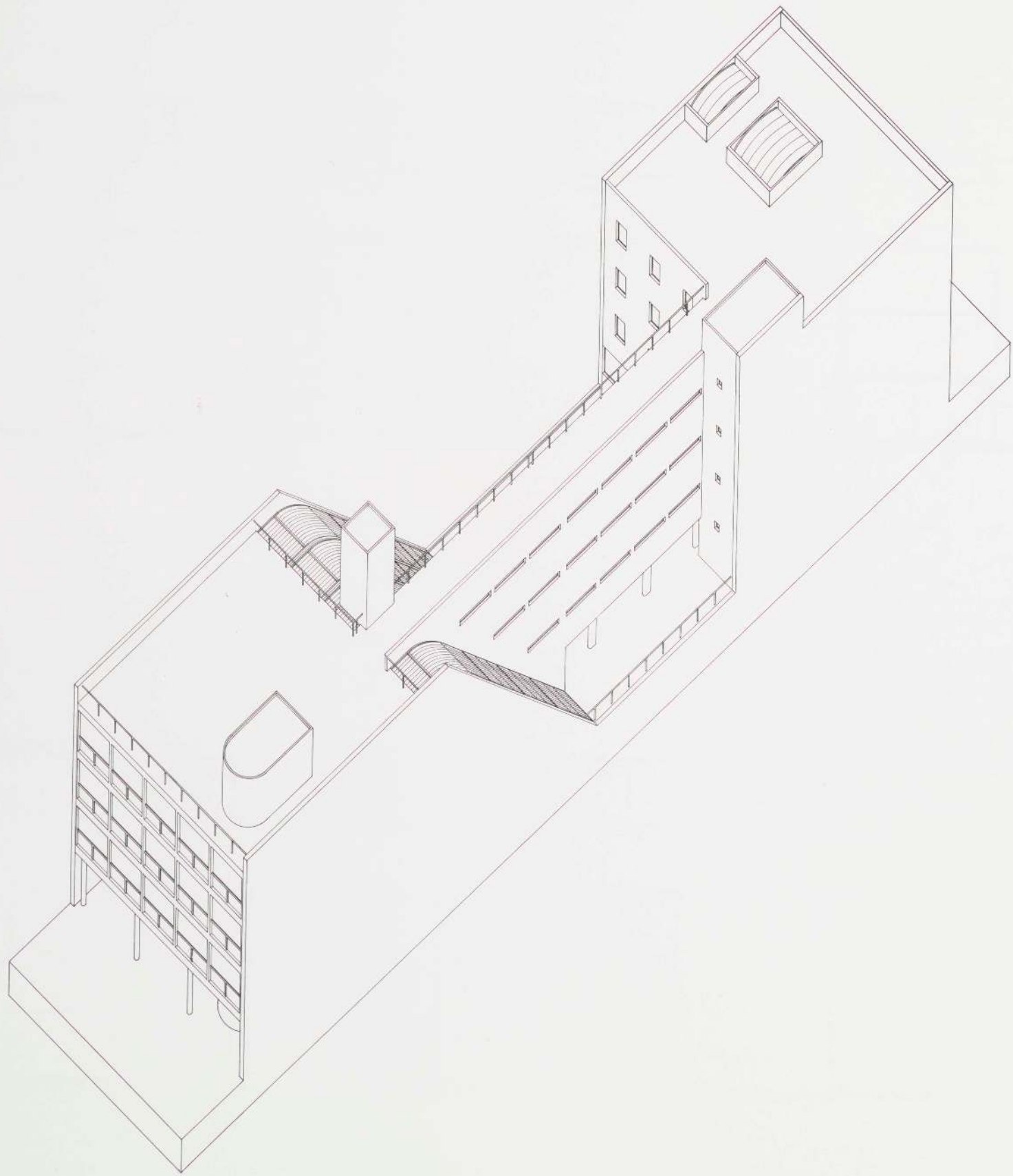

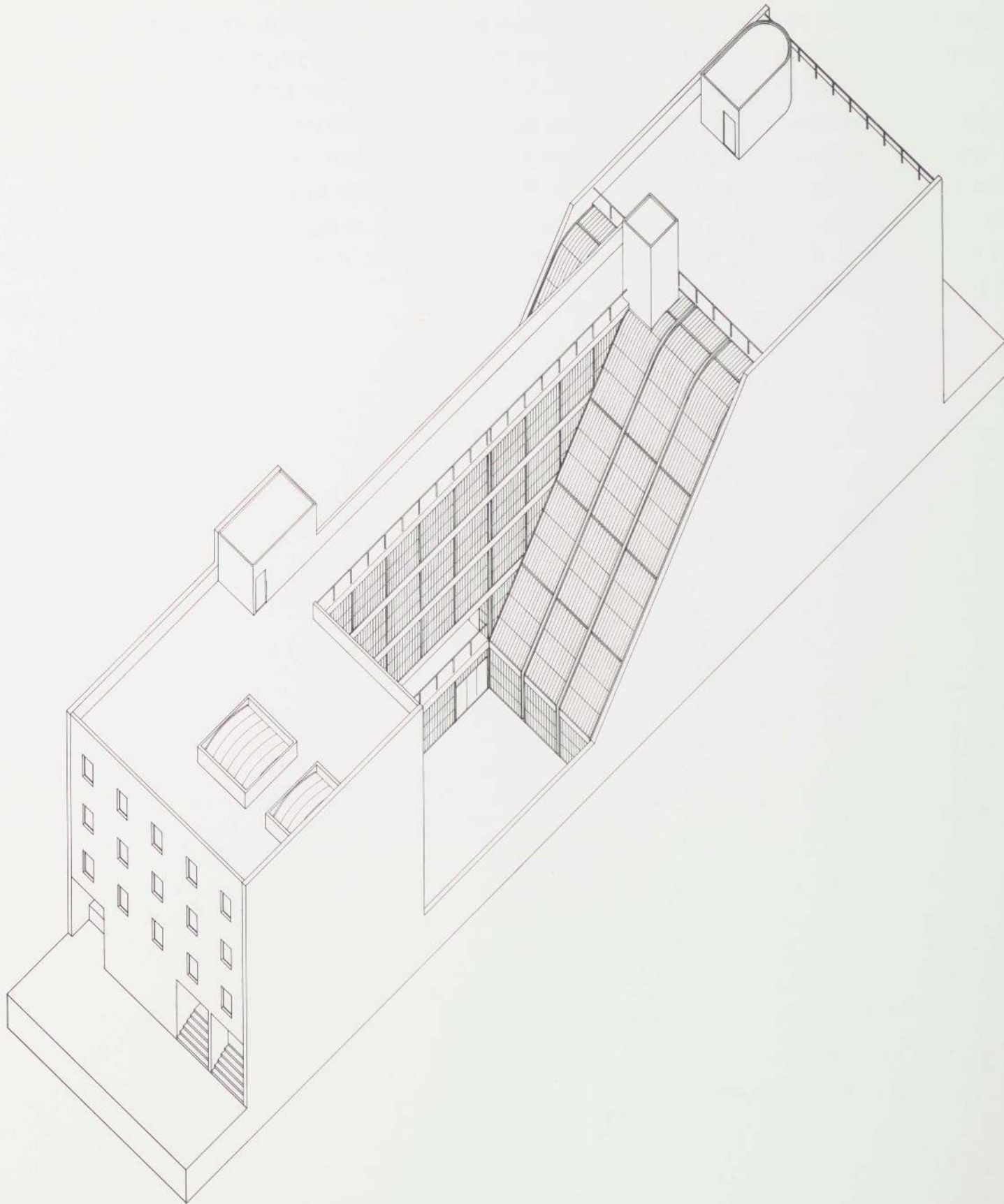

TEMPLE/LAWRENCE ERIC LEVINE. The Temple of the White Cloud is primarily an iconograph—a symbolic statement intended as a contrapuntal argument to its immediate surroundings. The Temple is situated in a dense, banal area of the city. It is flanked on both sides by huge, forbidding, Kafkaesque housing developments. Below is one of the world's busiest and most congested highways, along which pass Detroit's latest fantasies. The park below the Temple functions as a barrier to the noise and fumes of the traffic below. The Temple provides spiritual amenity in an area where it is lacking. The Temple is an air-inflated structure. The result is a huge enclosed space, undefined by columns or corners. The inside space thus begins to take on the qualities of an outdoor space. The attempt has been to create a microcosmic environment within this luminous shell, utilizing the typical architectural program for a synagogue. One can associate about the Temple; it is the whale that swallowed Jonah, it is the Tabernacle, it is the white cloud that guided the Israelites across the desert.



Lefrak City



L.I. expressway

97th pl.

98th st.

school

park city estates

TEMPLE SHEL ANAN LAVAN

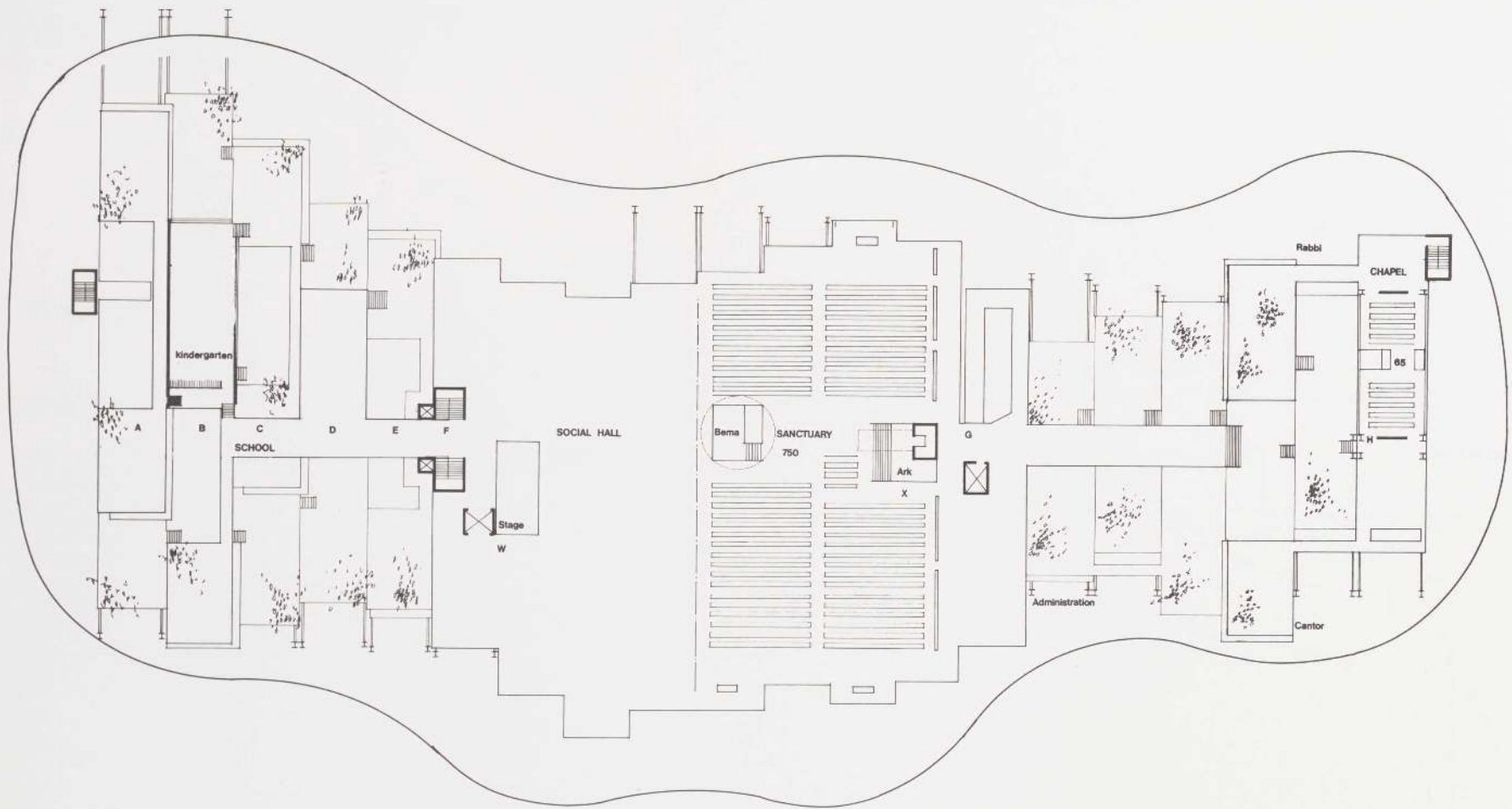

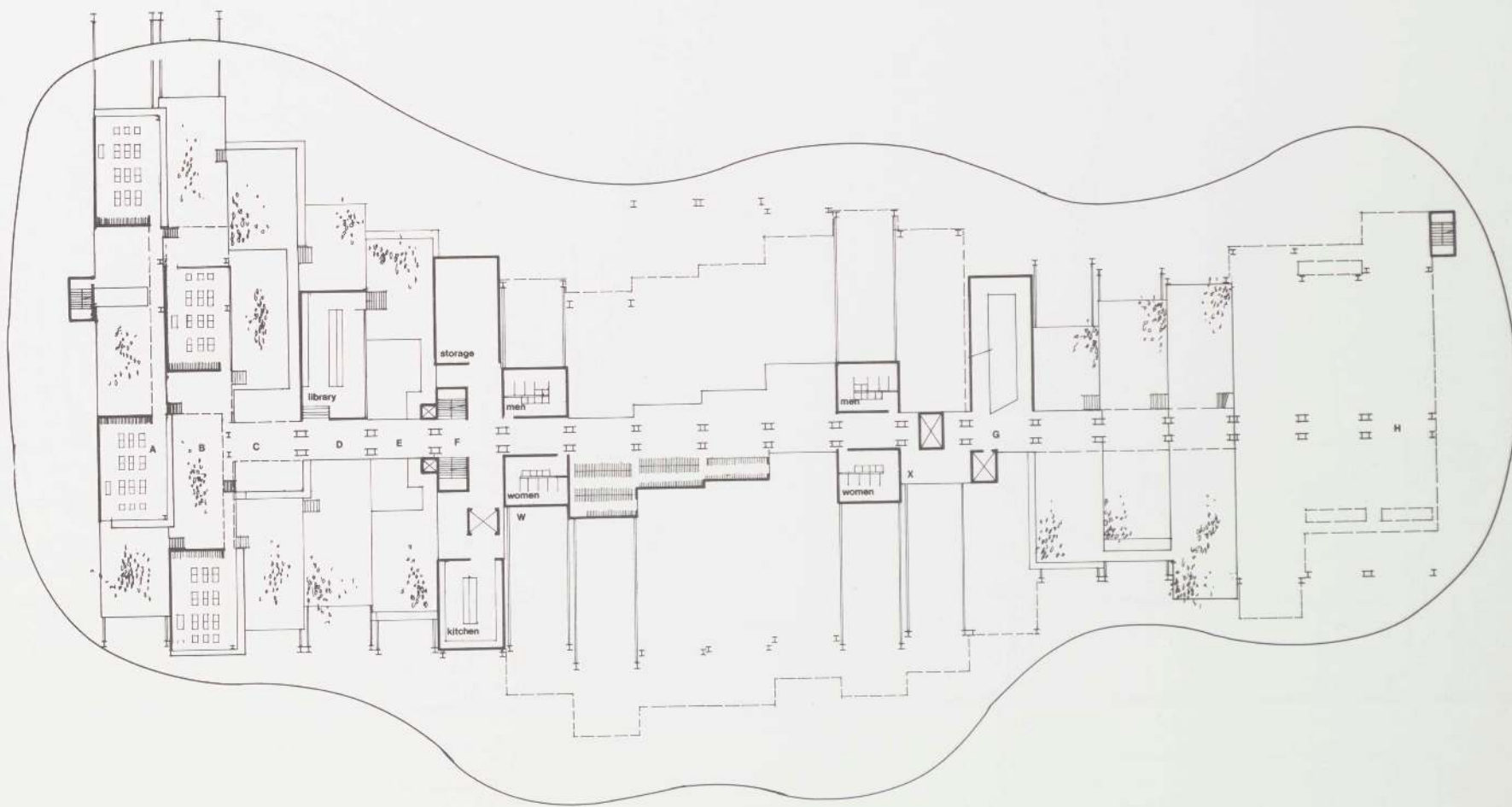

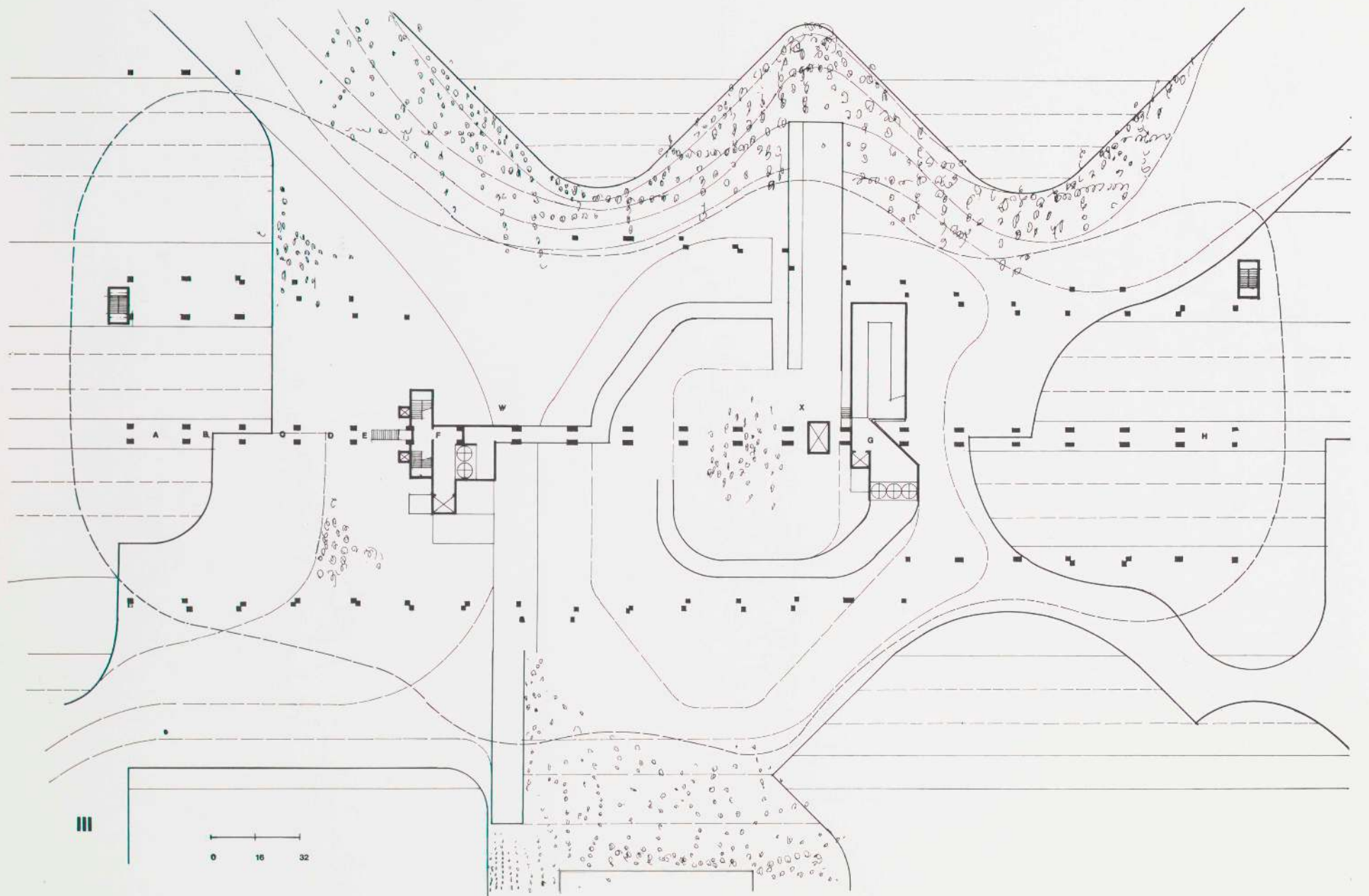

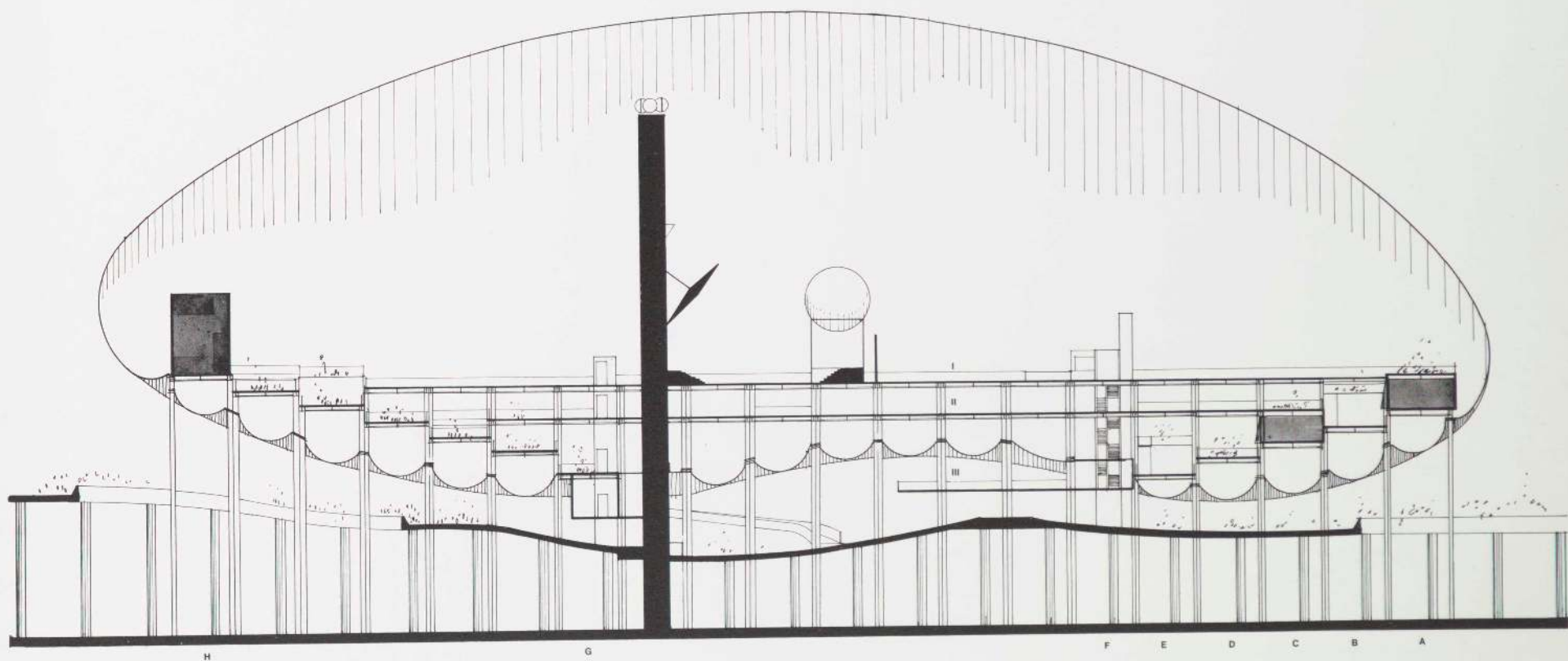

0 16 32

TEMPLE SHEL ANAN LAVAN

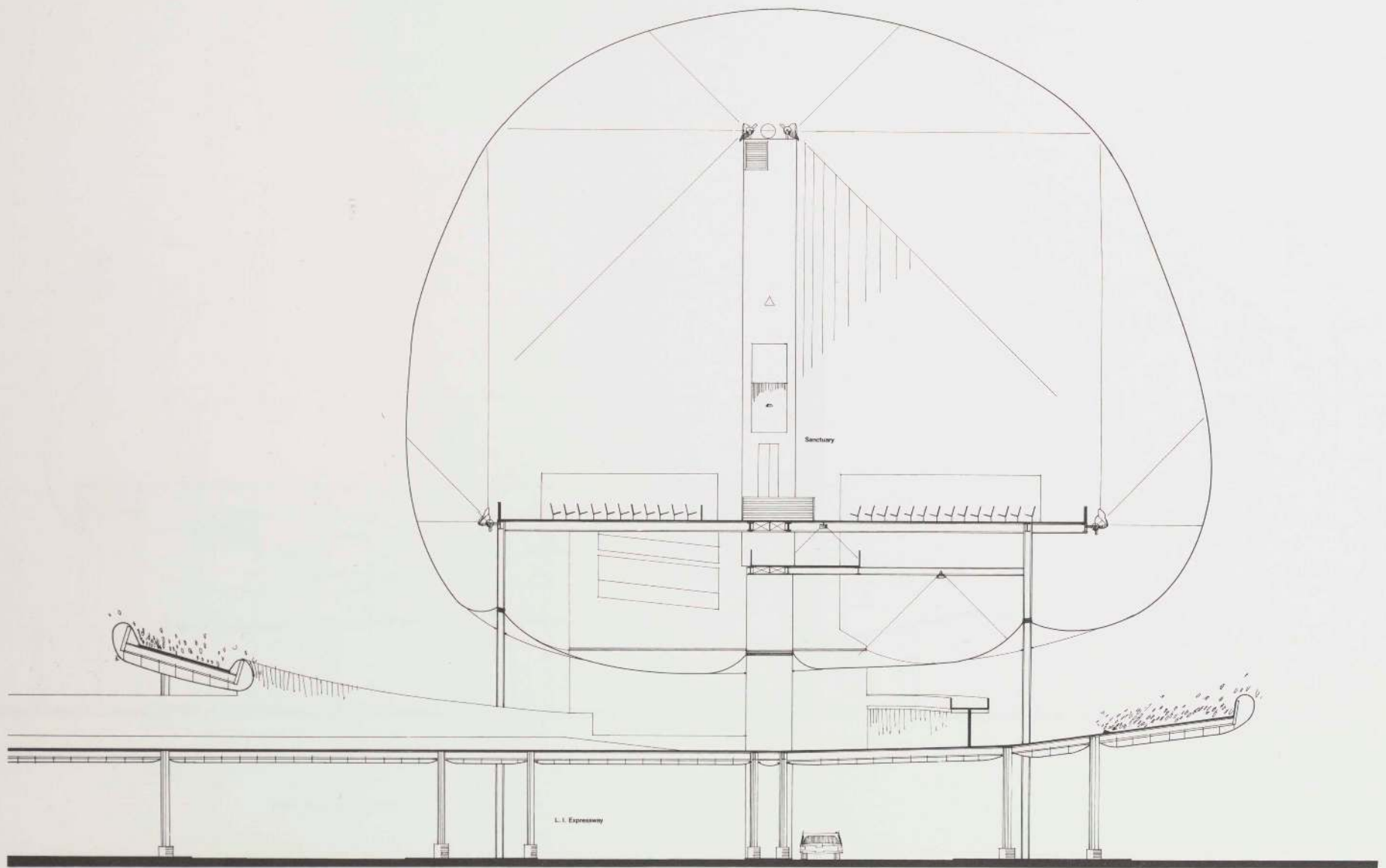

X

TEMPLE SHEL ANAN LAVAN

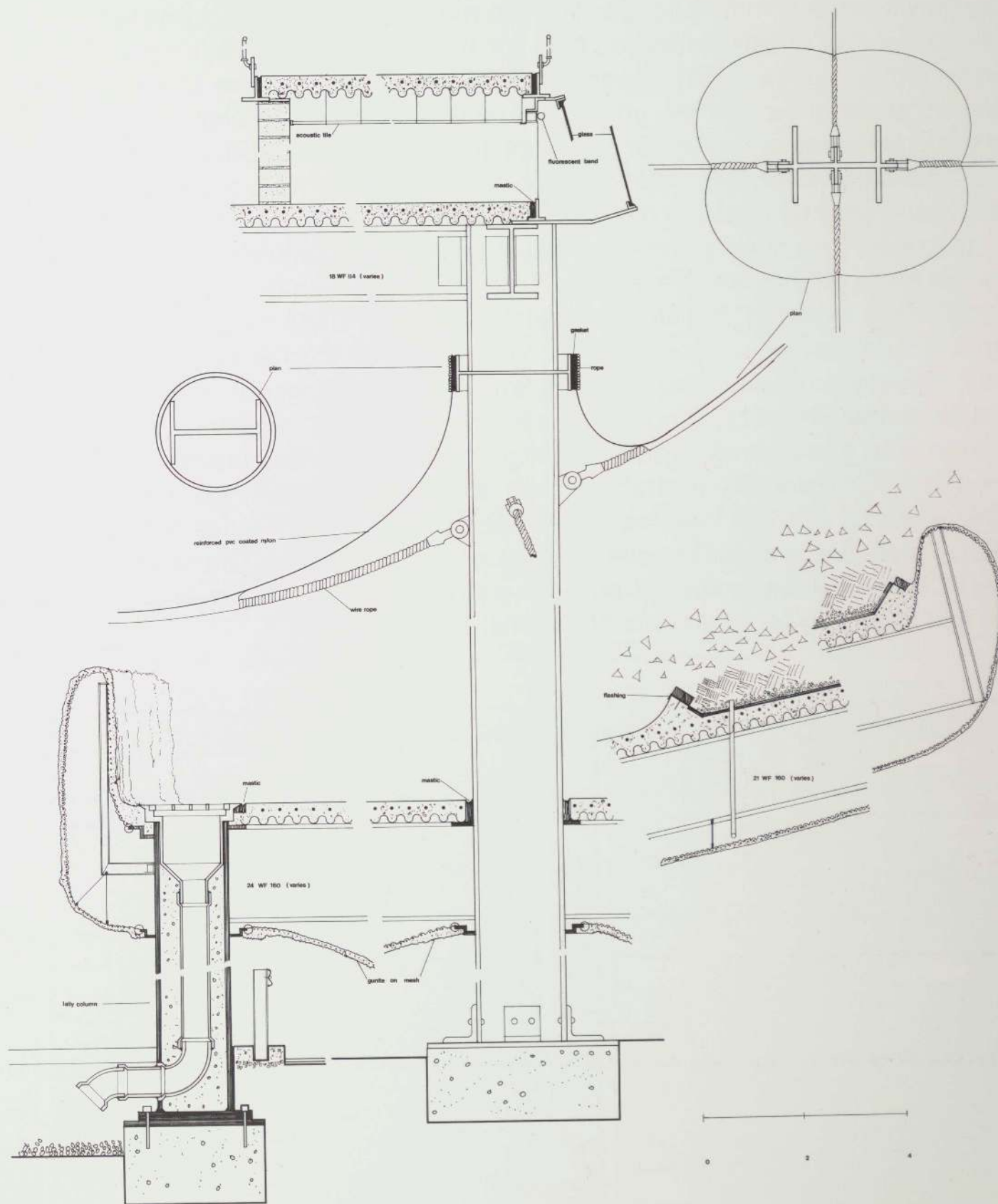

A STRUCTURE FOR CITIES/GEORGE ULTAN. A superficial analysis reveals the irrationality of a building industry that constructs foundations to last two thousand years, structures to last five hundred years, and curtain walls to last fifty or one hundred years for buildings whose usage may change in twenty years. Certainly, in such a highly mobile society, people should not be asked to live and work in environments constructed by previous generations. Values, attitudes, and expectations are changing so rapidly that one must re-examine the basic premises of traditional buildings. If change is required, then the ability to change must be provided. Toward this end, it is desirable to construct a unit with a planned obsolescence of about fifteen years that would directly relate to the current needs of the tenant. This unit should be 'clipped on' or 'plugged in', so to speak, to a more permanent structure and circulation pattern. Certainly, the permanent skeleton should last for more than one generation. Hence, a certain amount of flexibility should be provided within the systems of the skeleton. For example, while the route taken by the mechanical services may not change, the capacity and type of services offered should be able to change relatively easily. Similarly, the circulation system may undergo slight modification, while the basic concept of the system remains the same. Thus, the less variable qualities of building, structure, circulation, and mechanical services are reflected in a permanent skeleton. The more variable qualities of usage and technical facilities are expressed through a more temporary unit. A socially desirable bonus is achieved through this approach: after about fifteen years, even if the needs of a tenant have not ostensibly changed, the occupant is forced to undergo a systematic evaluation procedure in order to determine his new environment. This rather frequent change in the form and quality of the individual units will produce a total structure whose external form varies naturally with the diverse and changing requirements of its tenants.

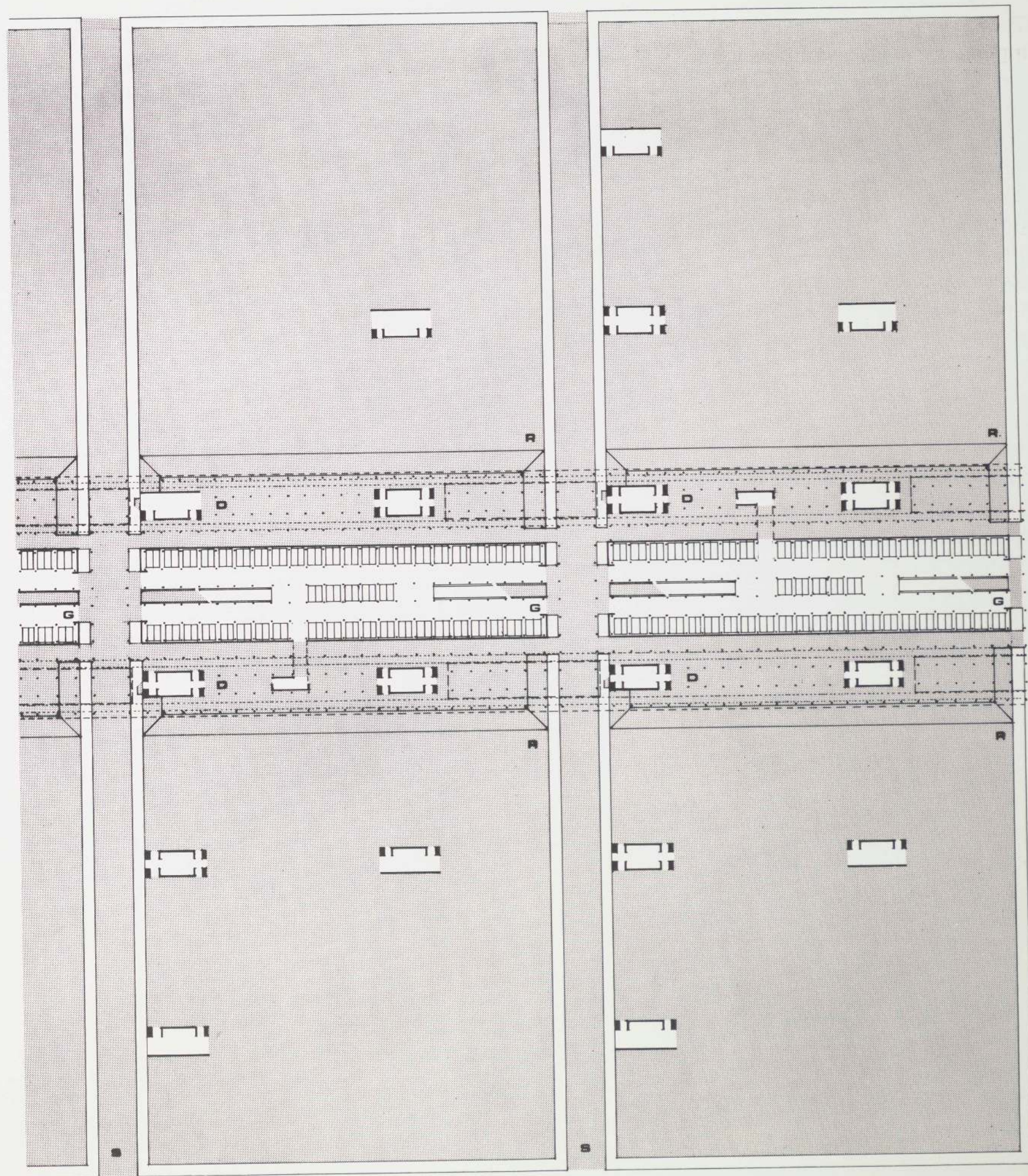

PLAN AT 0' - 0"

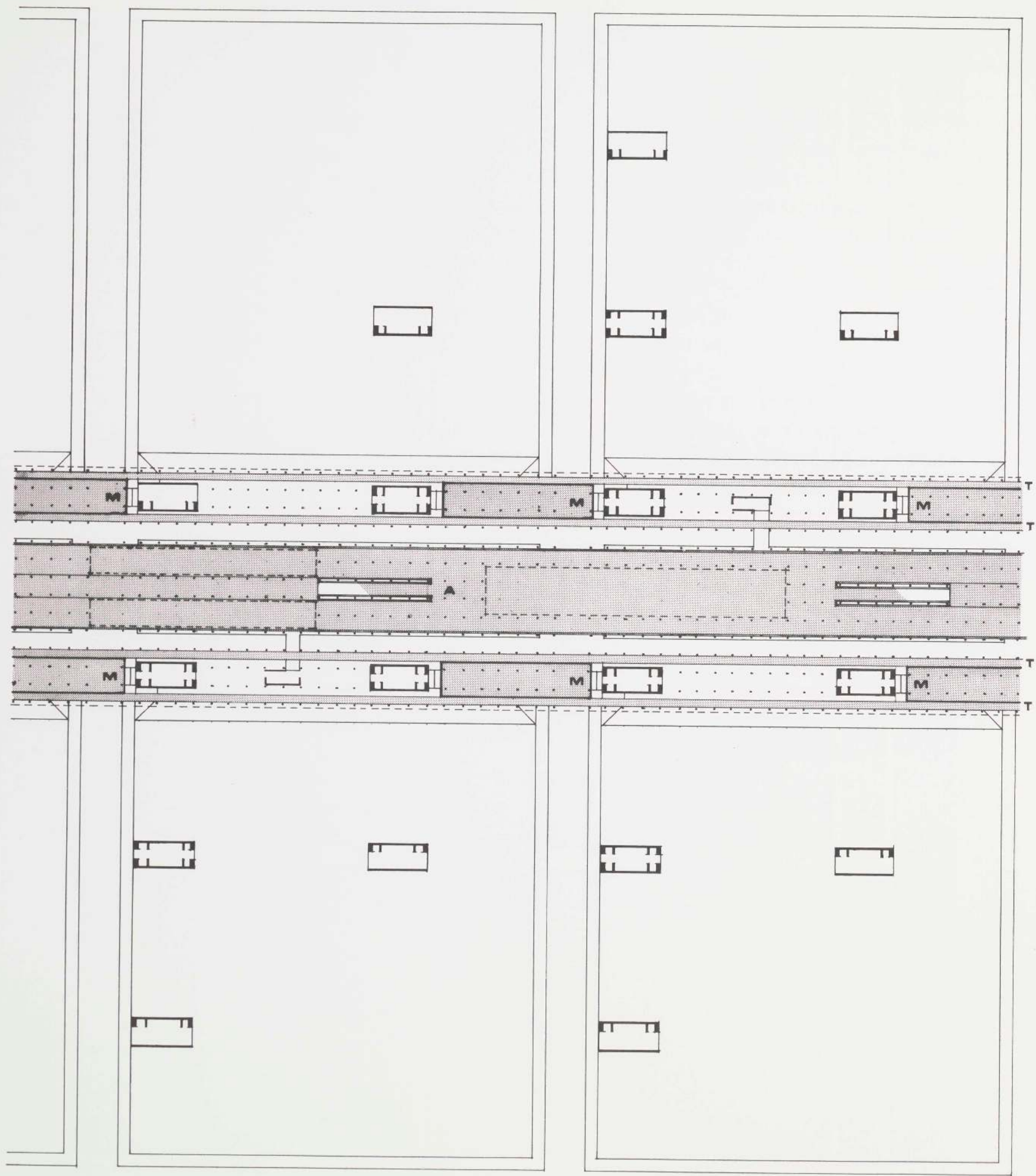

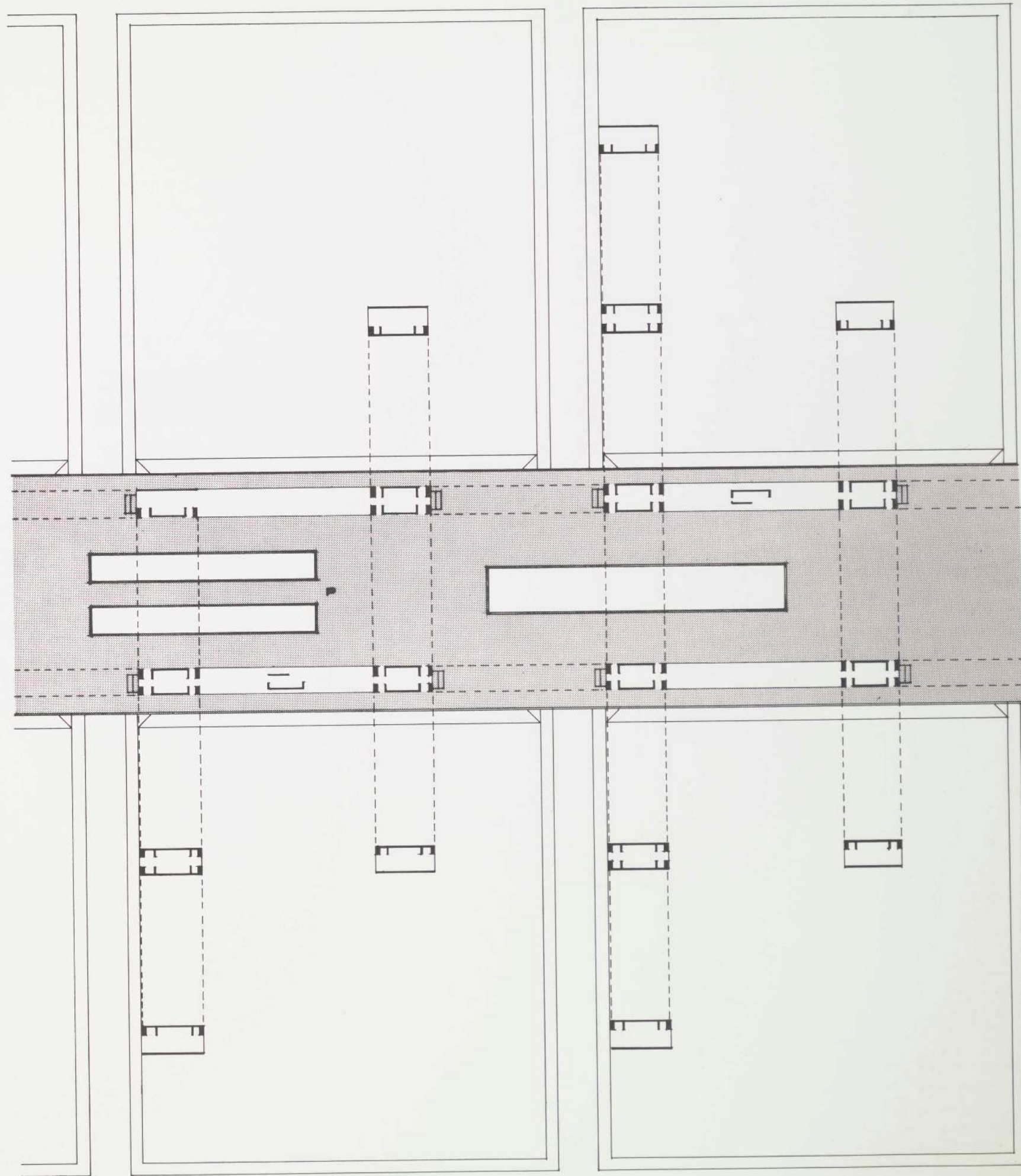

PLAN AT 50' - 0"

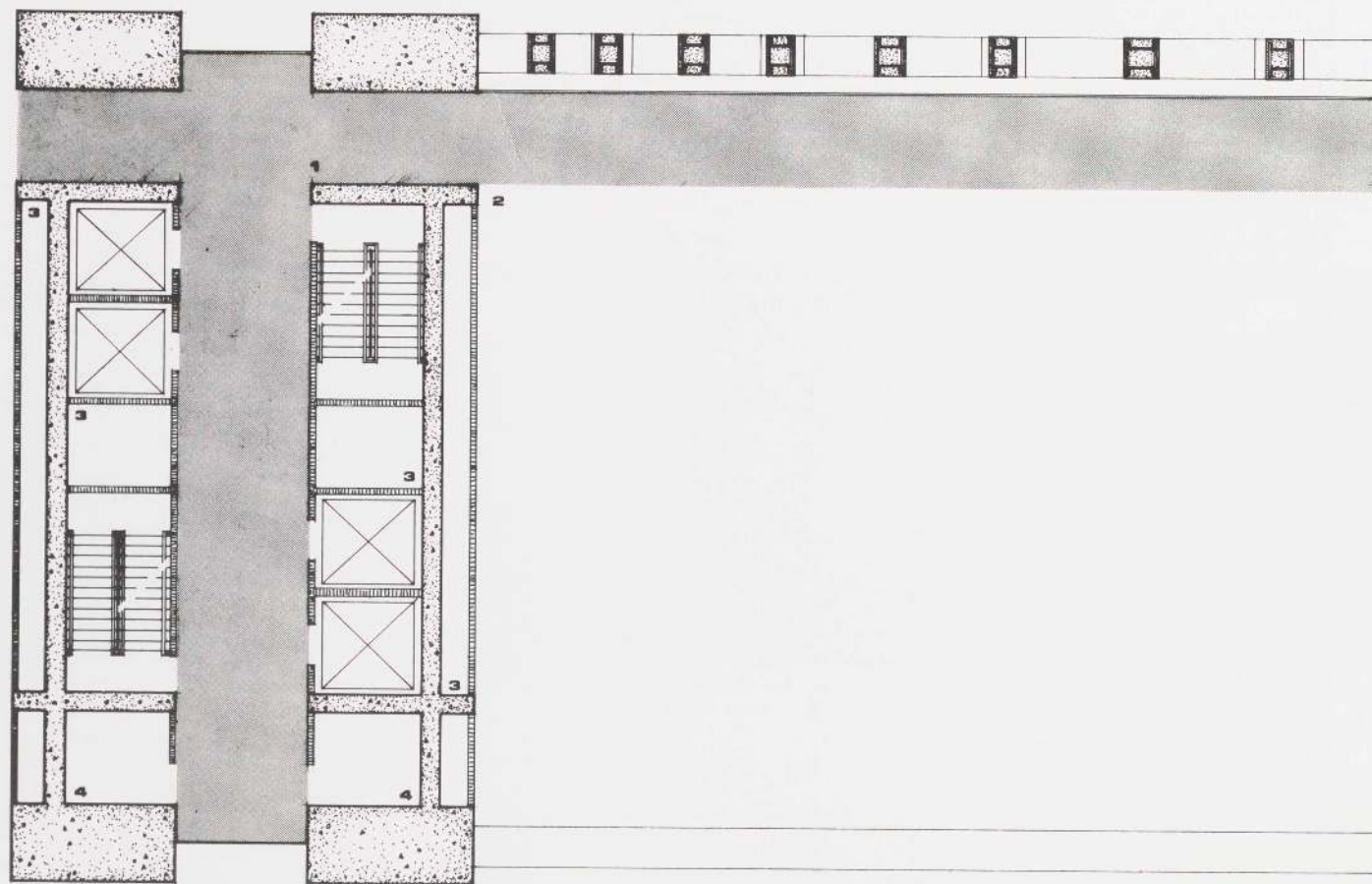

PARTIAL PLAN

- 1 PEDESTRIAN
CIRCULATION STREET
- 2 RENTABLE FLOOR AREA
- 3 DUCT SPACE
- 4 STORAGE

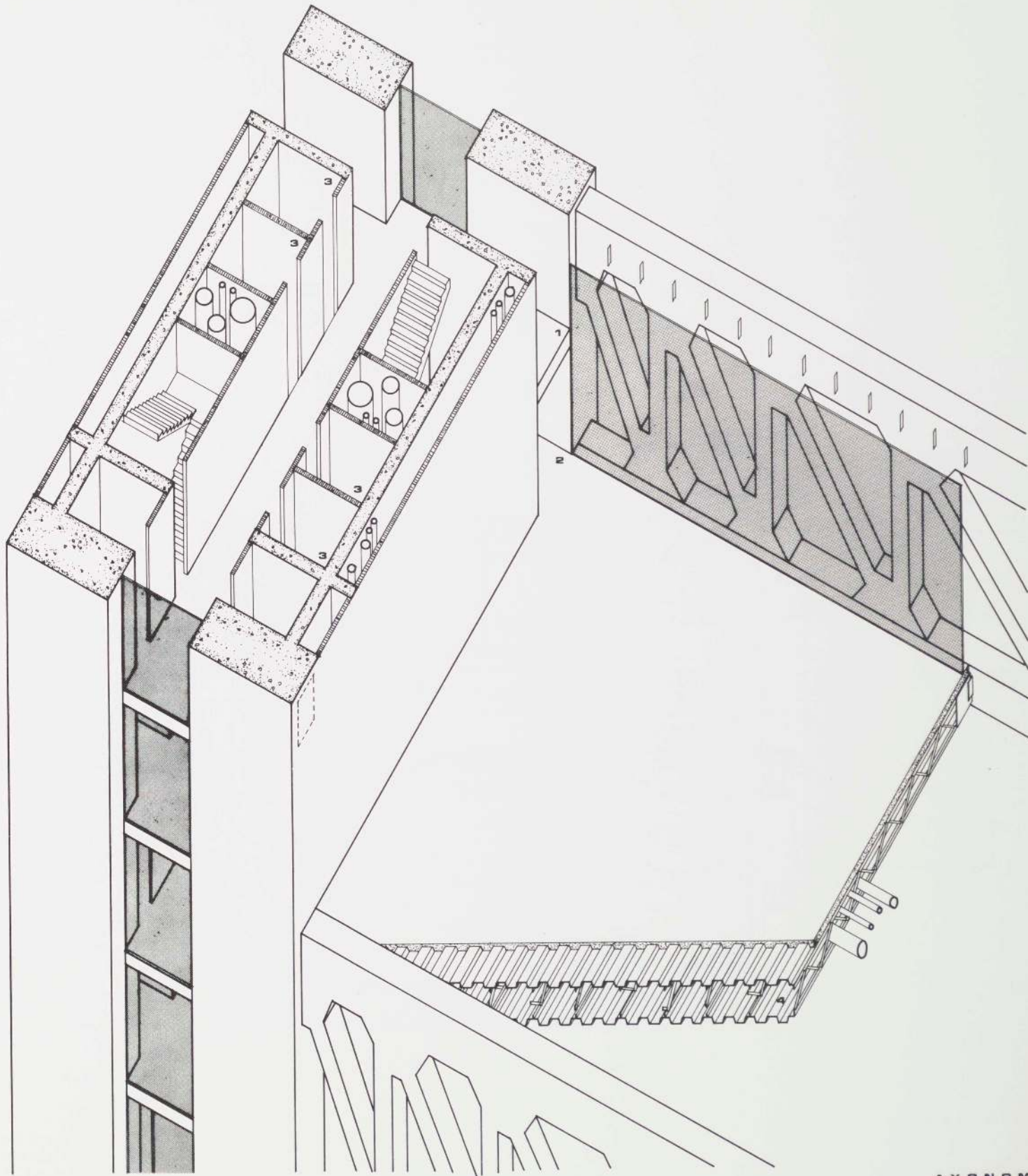

AXONOMETRIC

1 SERVICE LEVEL

2 PEDESTRIAN LEVEL

3 ELEVATOR

4 STRESSED SKIN STEEL
STRUCTURAL SYSTEM

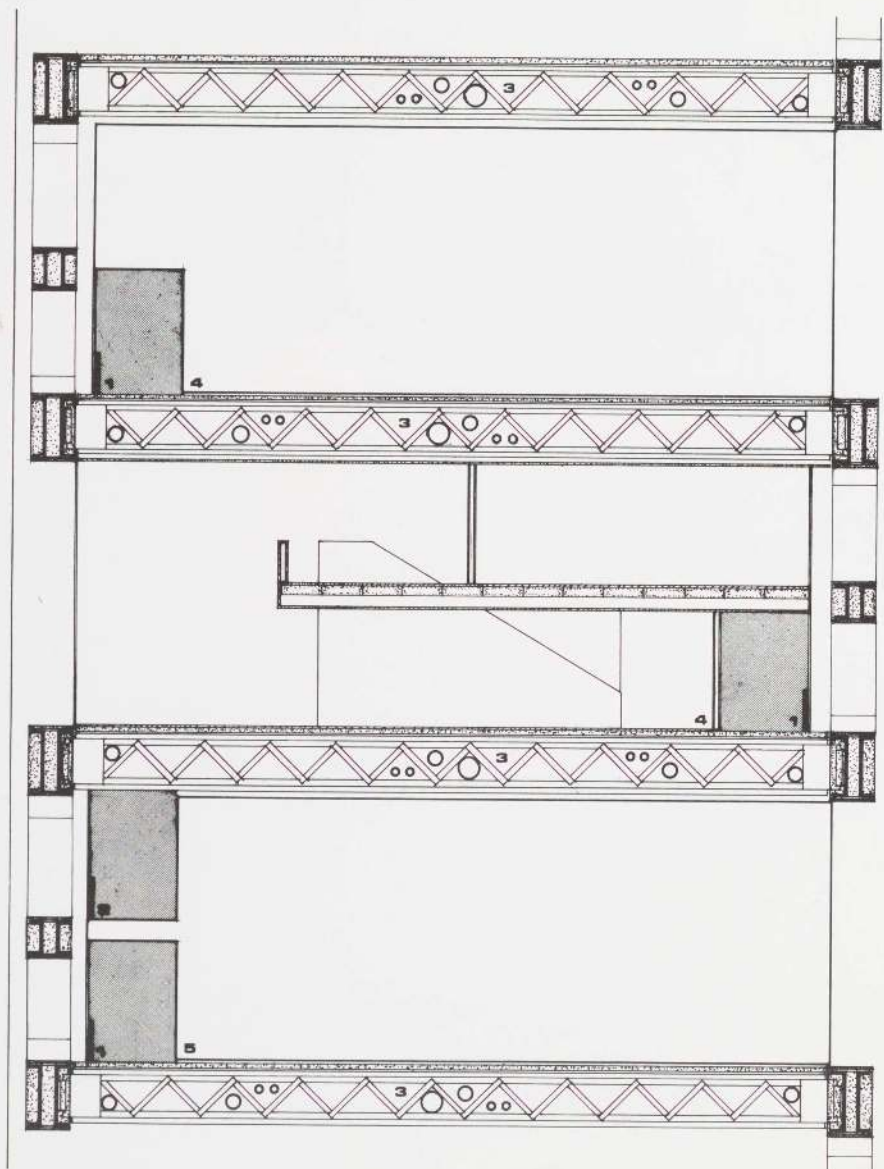

SECTION

- 1 PEDESTRIAN CIRCULATION STREET
- 2 SERVICE CIRCULATION STREET
- 3 DUCT CIRCULATION SPACE
- 4 TYPICAL PROFILE OF RESIDENTIAL UNIT
- 5 TYPICAL PROFILE OF RETAIL OR LIGHT MANUFACTURING UNIT

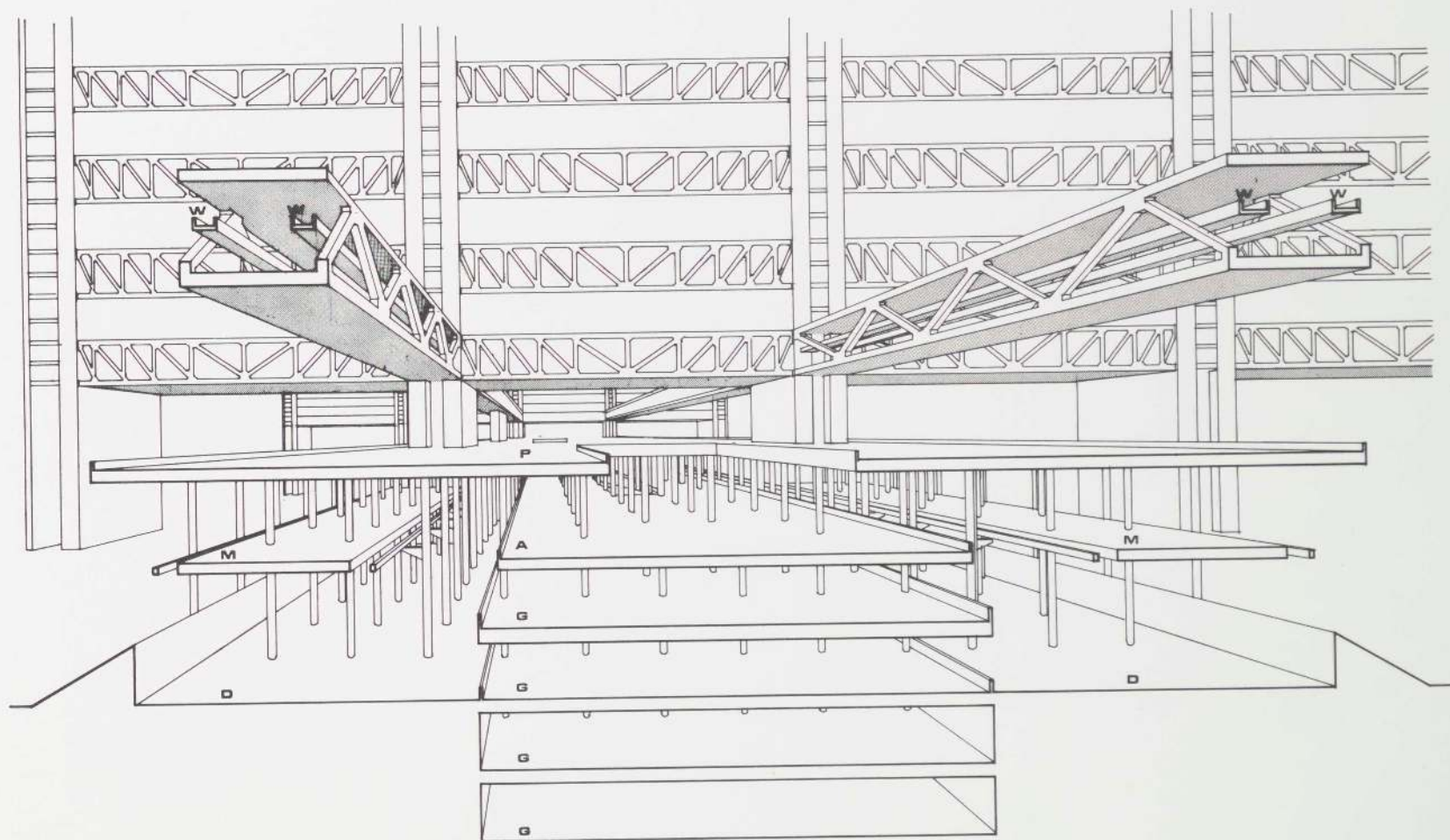

SECTION - PERSPECTIVE

A VEHICULAR AVENUE
D DELIVERY AND SERVICE
AREA
G GARAGE
M MONORAIL STATION
P PEDESTRIAN AVENUE
W MOVING WALKWAY

HOUSING/ALFONSO RODRIGUEZ, NICHOLAS SCHNEIDER, BARTHOLOMEW SILBERSTANG.
The slabs, rising above multi-storey parking, consist of a central exterior circulation and mechanical system flanked to the north by a continuous wall of apartments and to the south by a variety of interior spaces, stairs, elevators, laundry, storage, professional apartments, workshops and studios, and extensive exterior balconies with fireplaces, sculpture, murals and play areas—all giving the central circulation a street character, establishing a grade level at every second or third level.

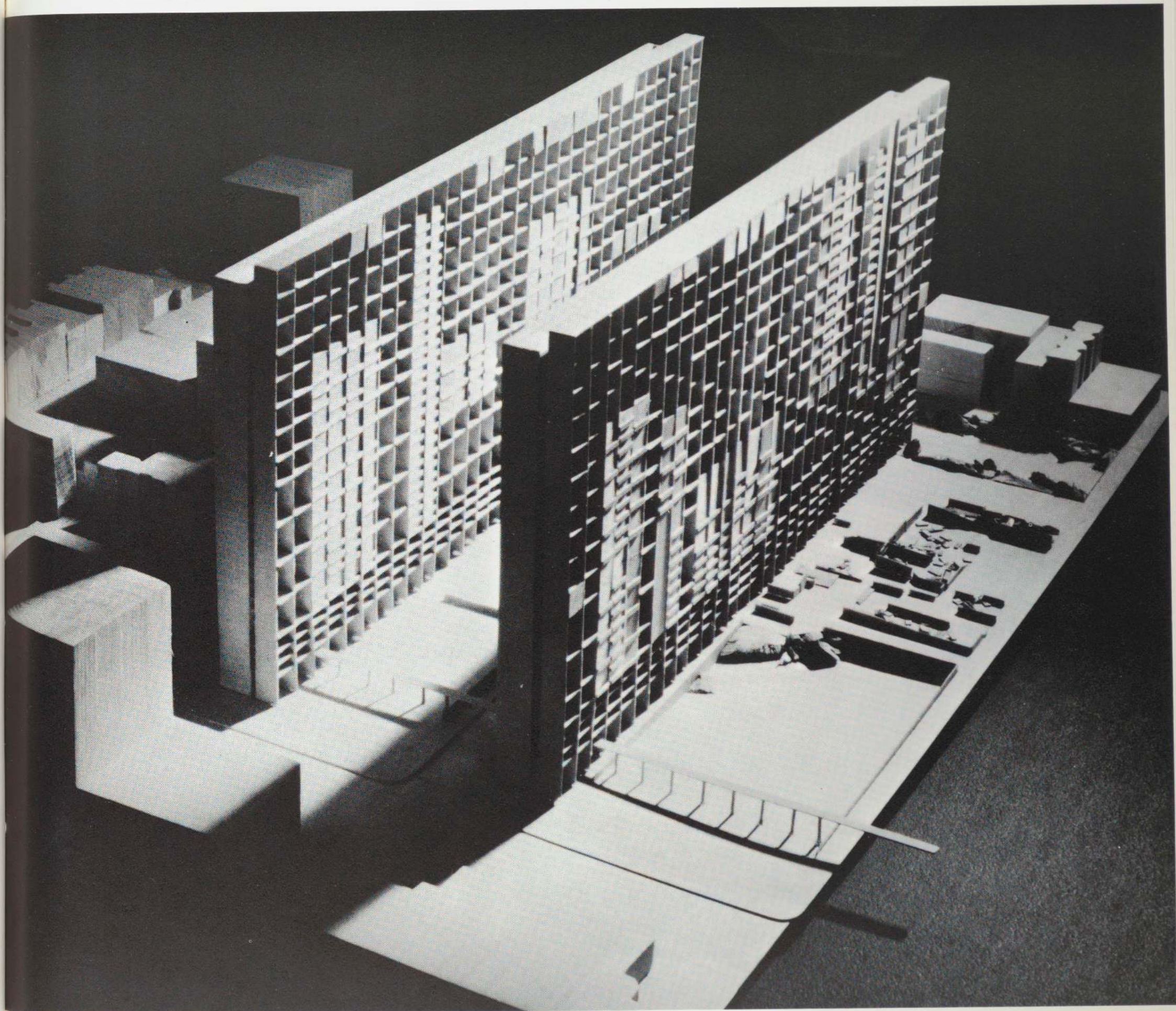

MADISON SQUARE GARDEN PROJECT/ROY P. FRANGIAMORE. At the time of this design I was interested in doing a large project involving several areas of general investigation, not internally generated out of strictly formal or symbological considerations but having more to do with the requirements of a specific program and place. The Madison Square Garden Development was an extremely complicated program with tremendous restrictions in terms of circulation, construction, conflicting uses, and strong urban design requirements. I was also interested in inflatable structures and the combining of the mathematics of the super-ellipse and a proportioning system based on the golden-section rectangle.

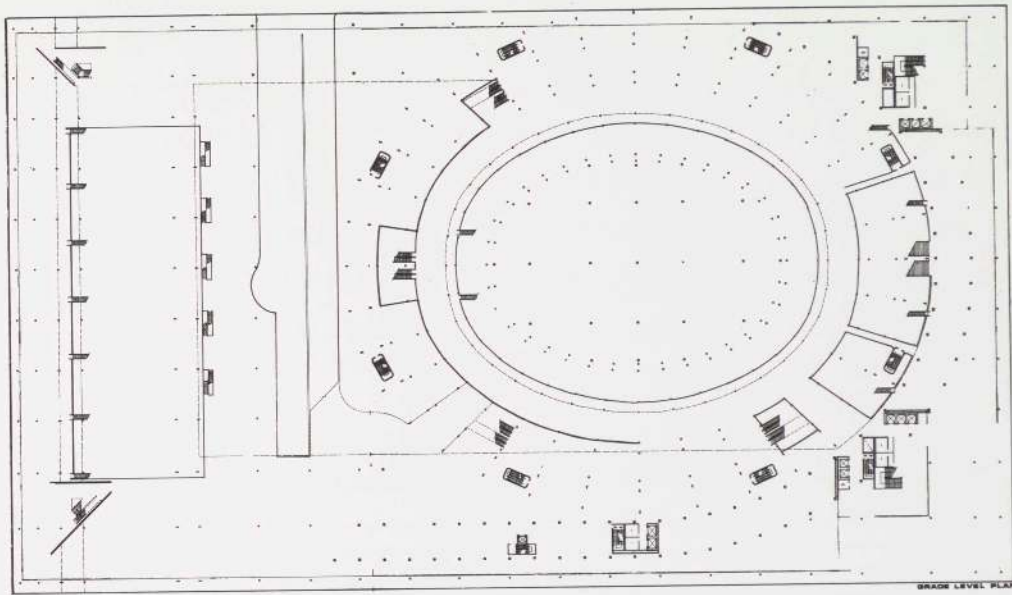

GROUND LEVEL PLAN

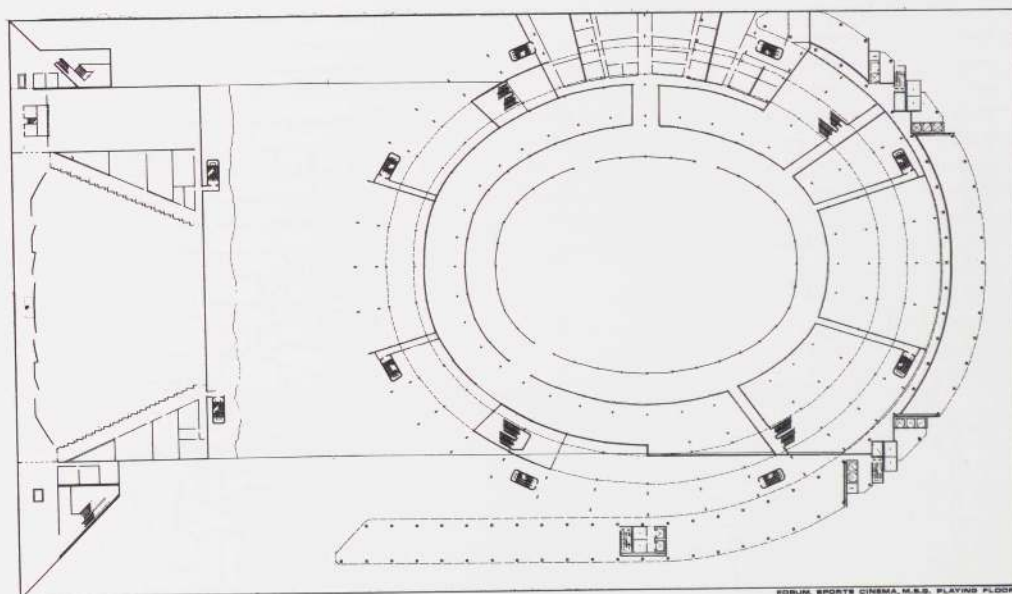

FORUM, SPORTS CINEMA, M.S.B. PLAYING FLOOR

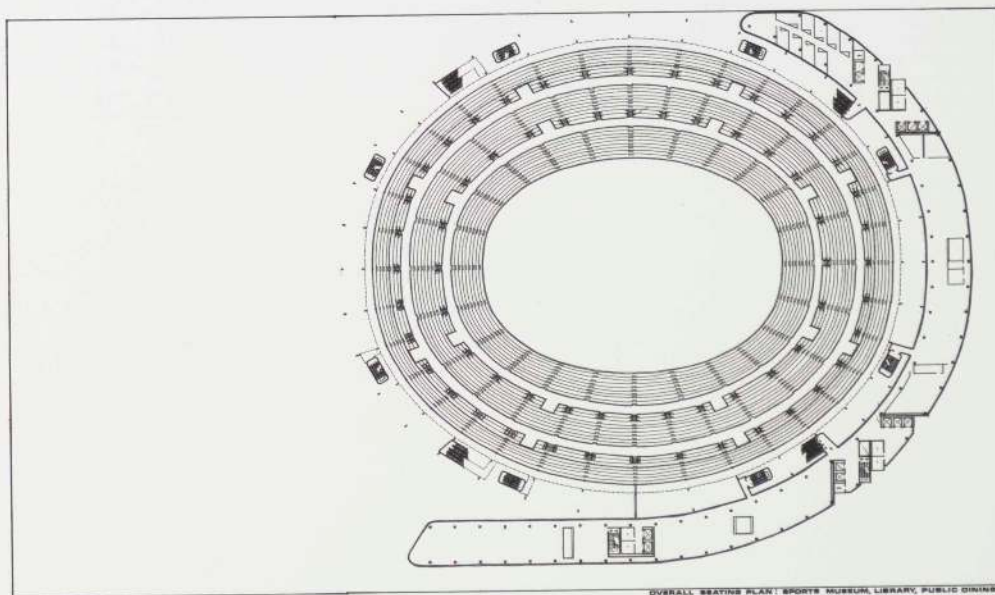

OVERALL SEATING PLAN: SPORTS MUSEUM, LIBRARY, PUBLIC DINING

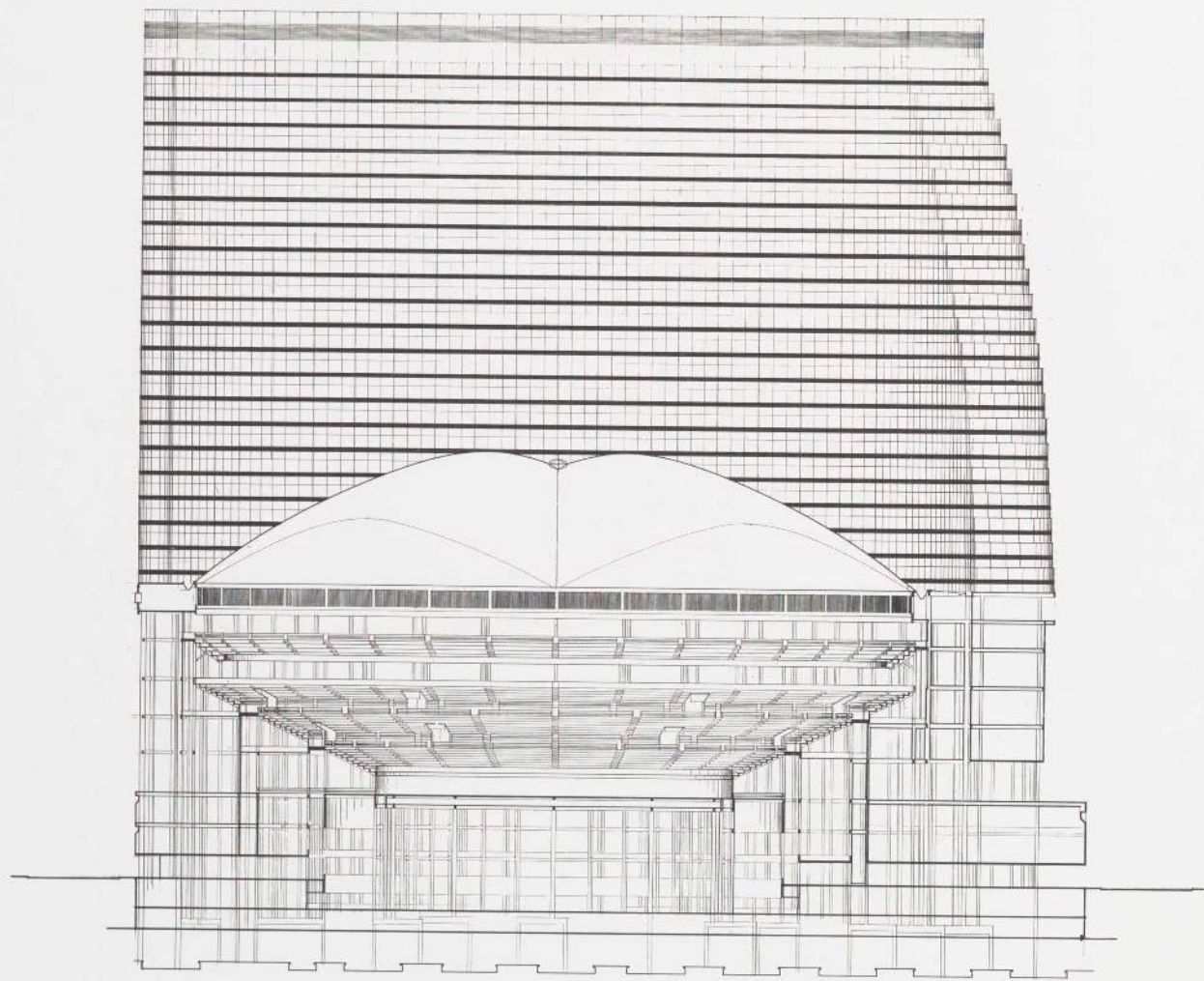

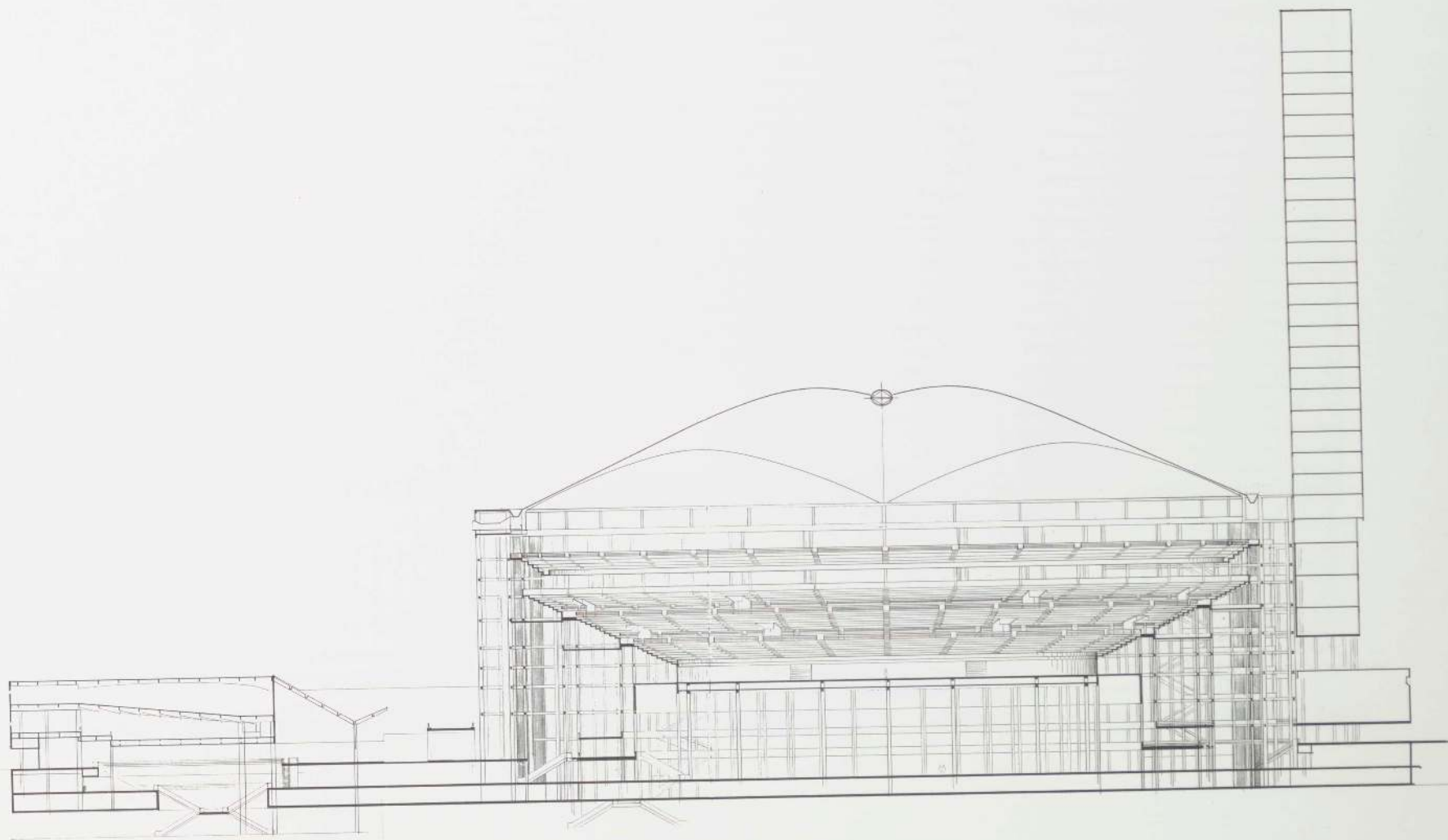



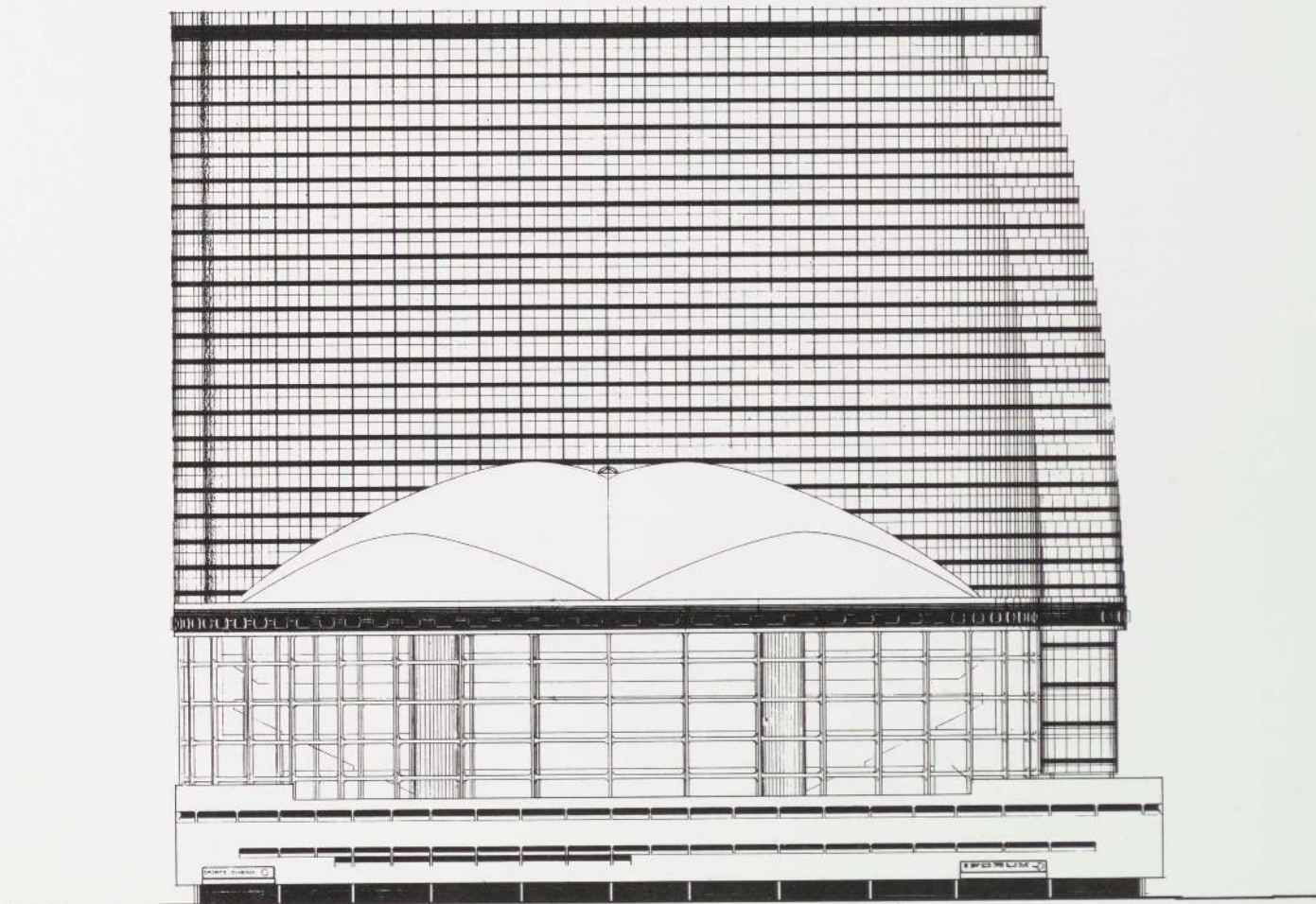

SHIP ON A DESERT/YAN KORZYBSKI. A dialectic of many and one arises from interdependent spatial energies active within a self-defined field.

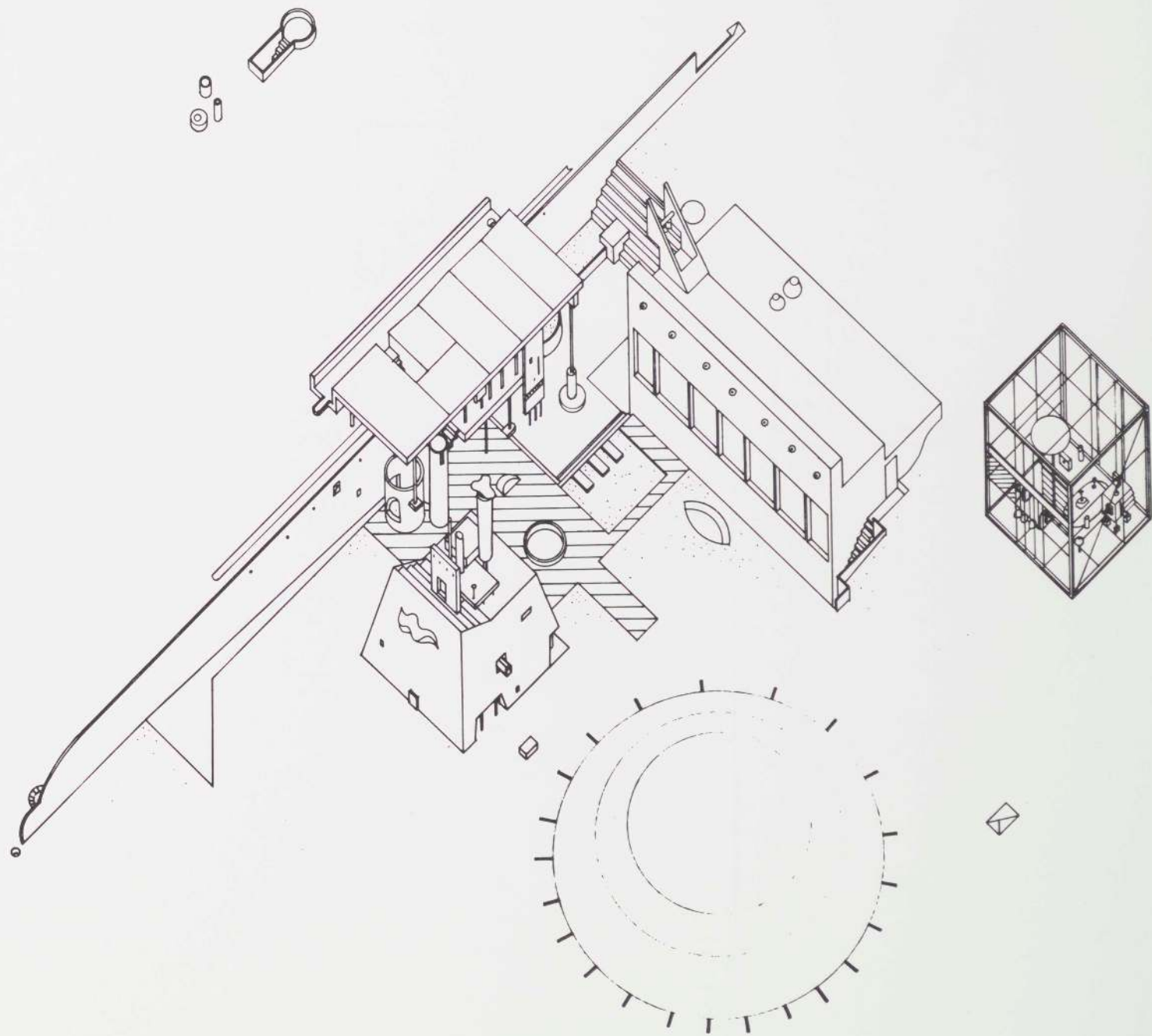

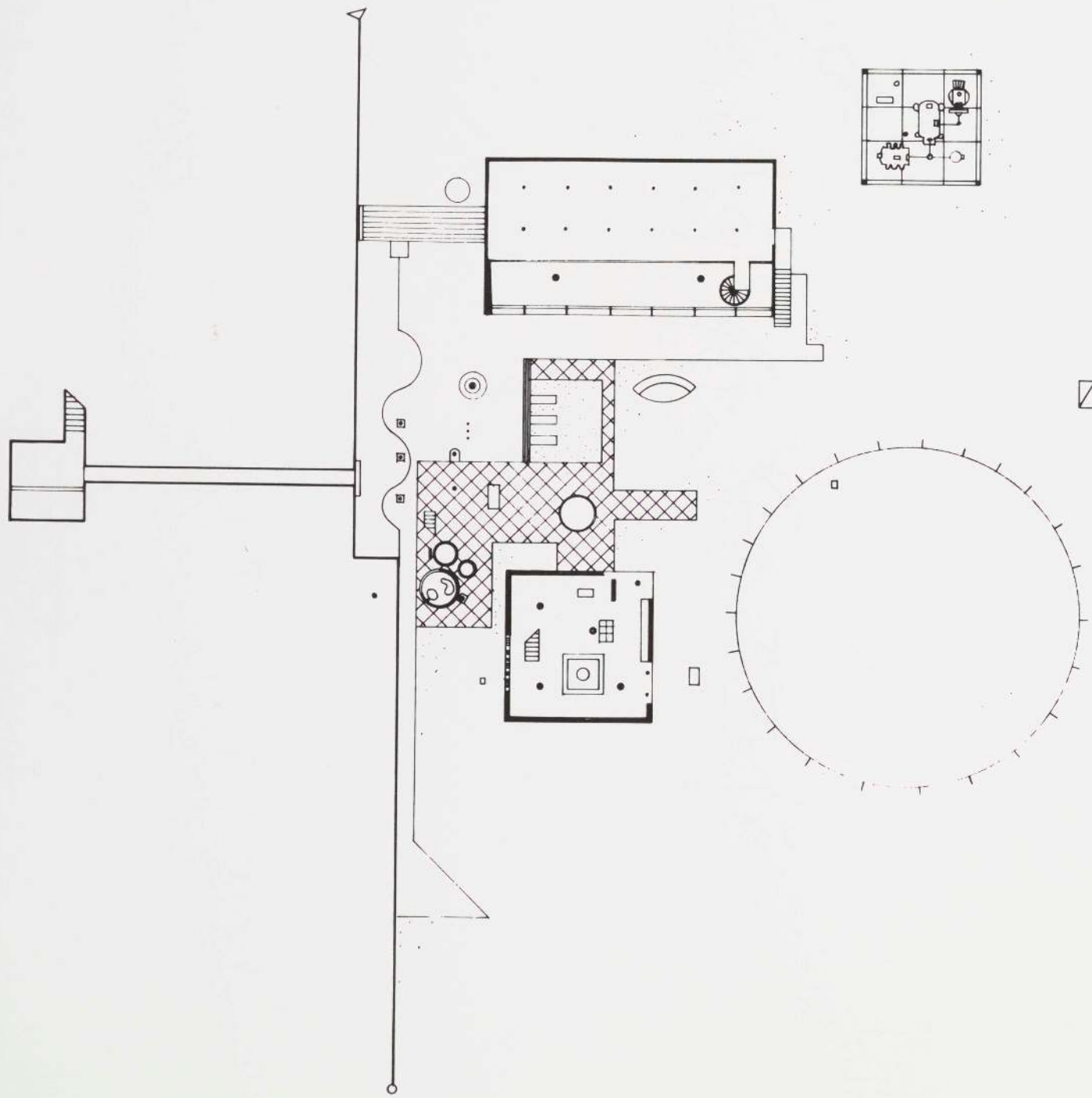

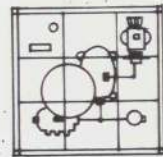
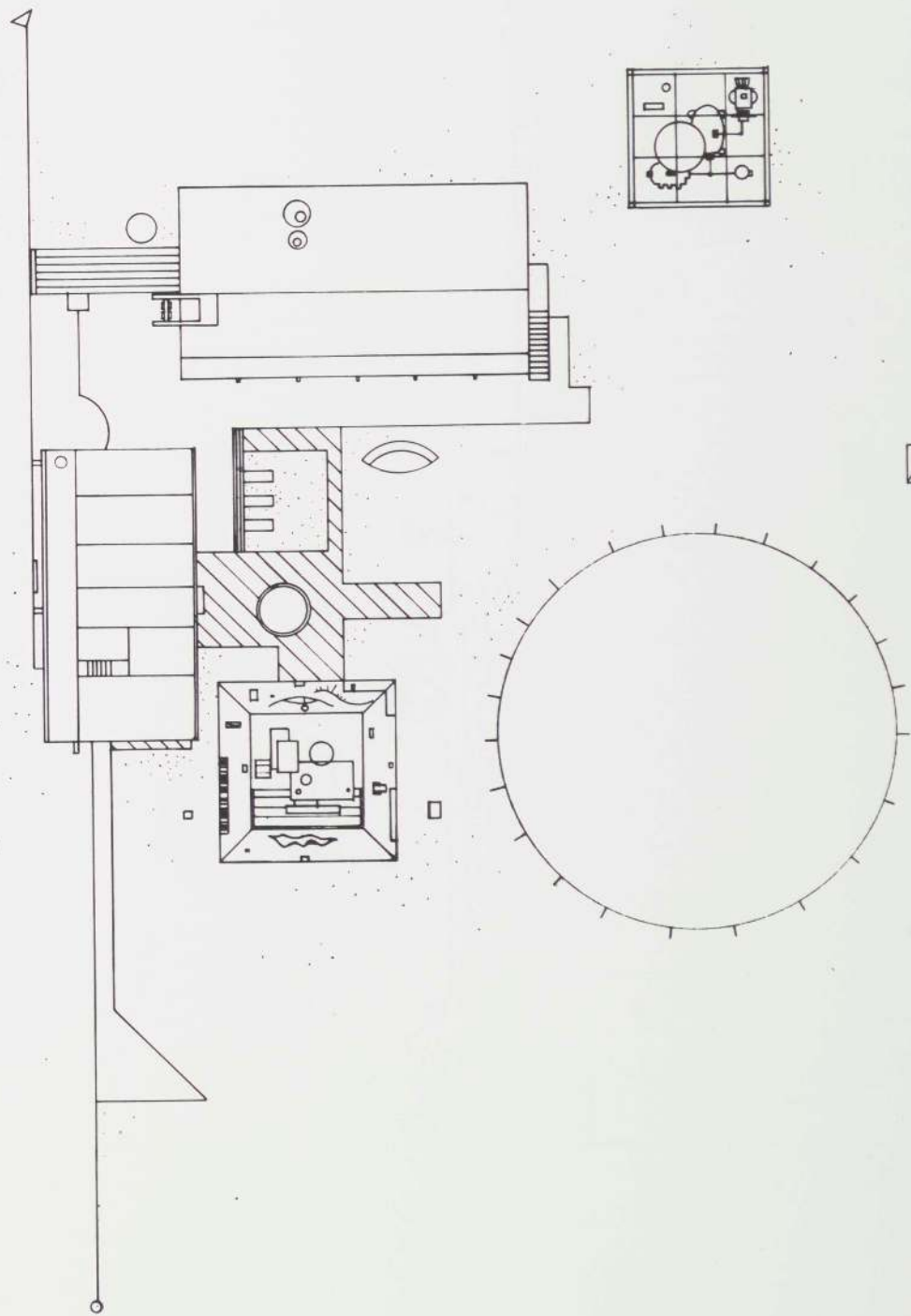

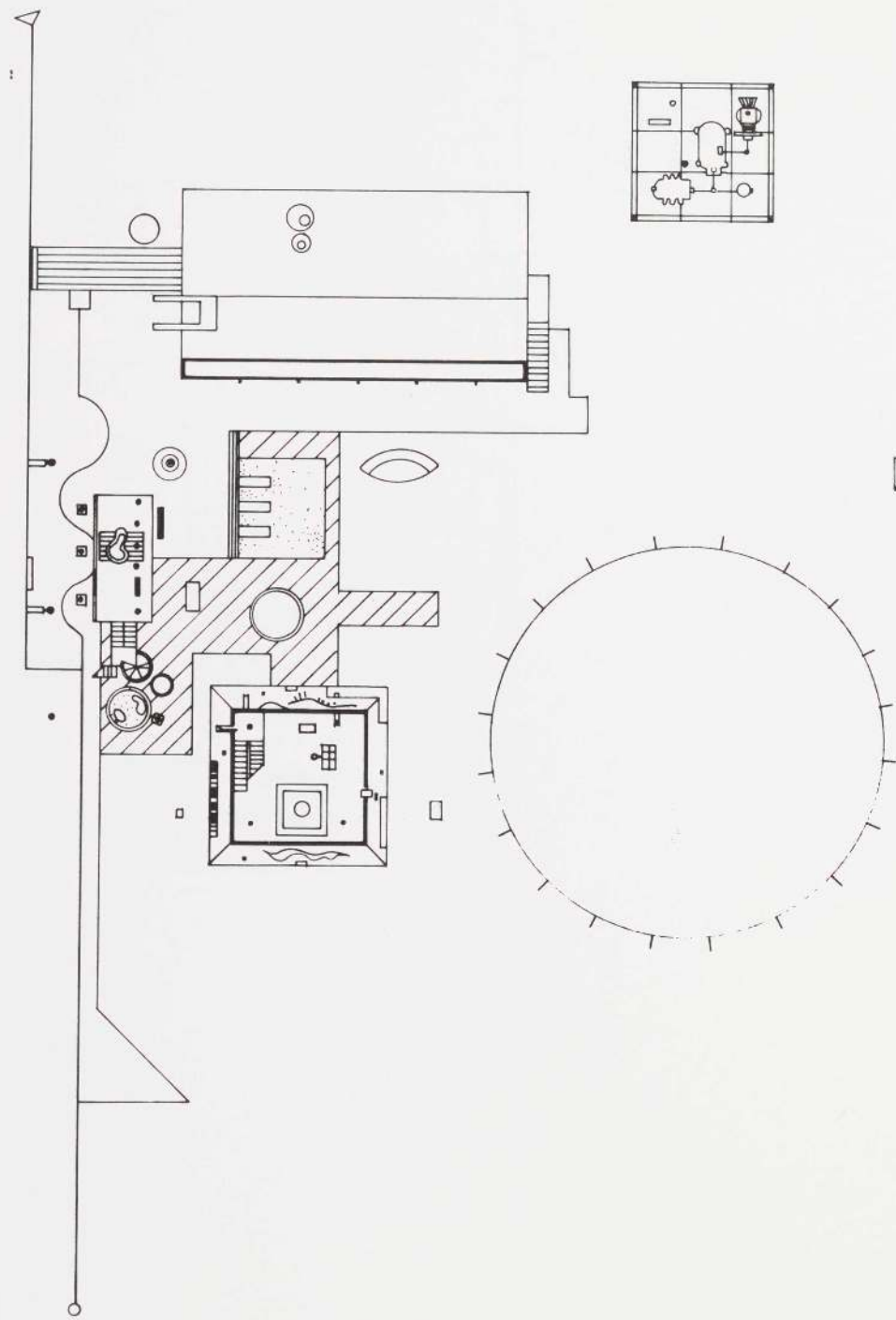

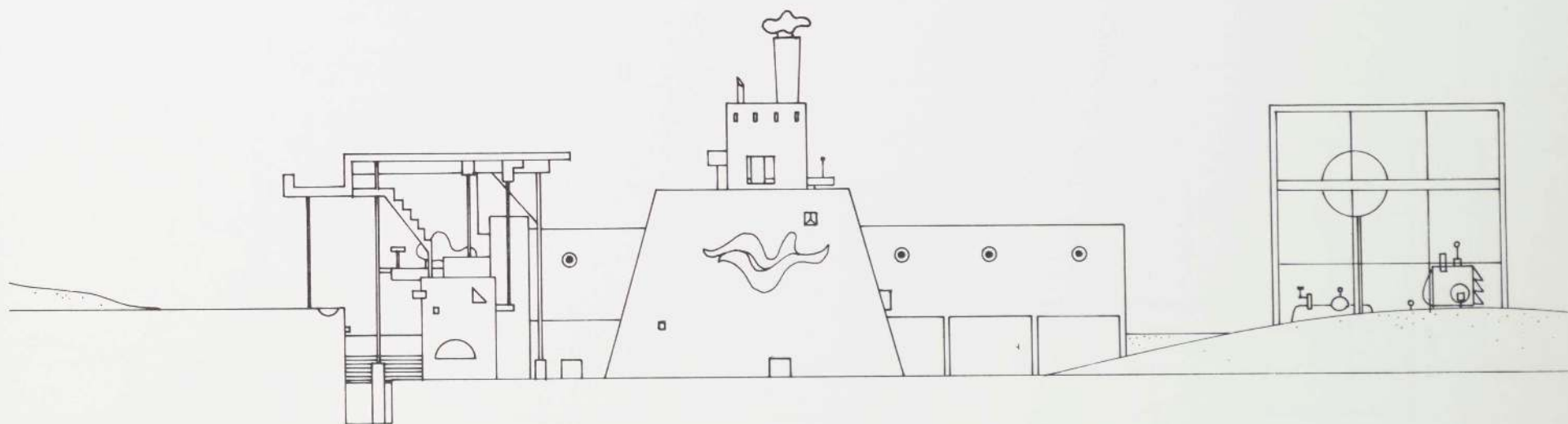
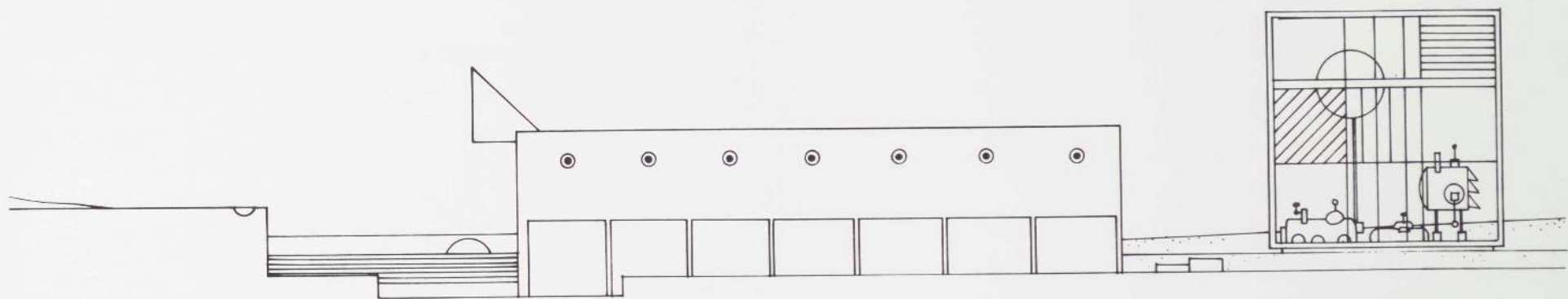

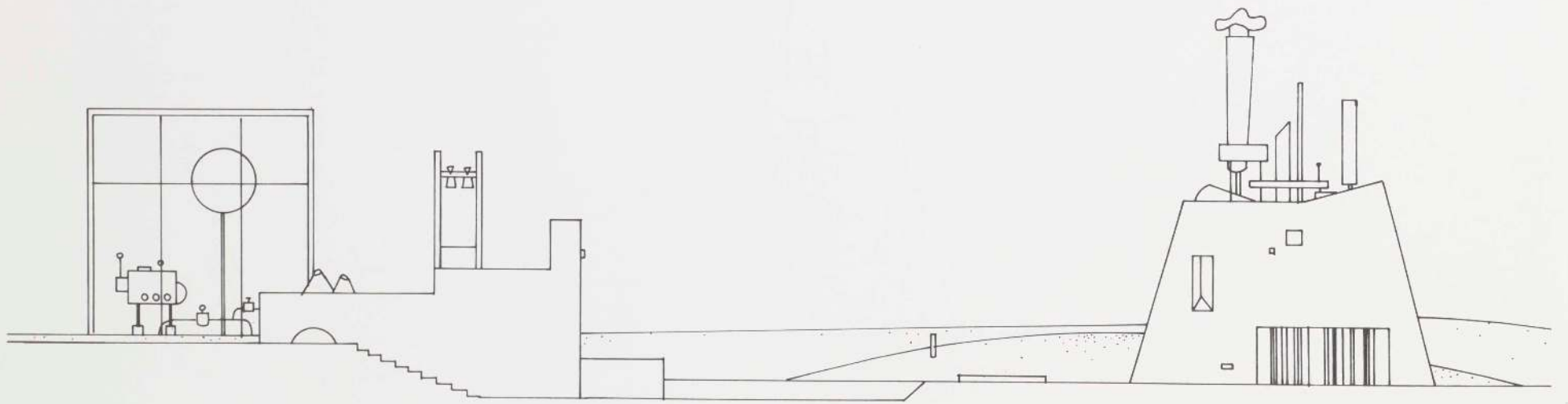
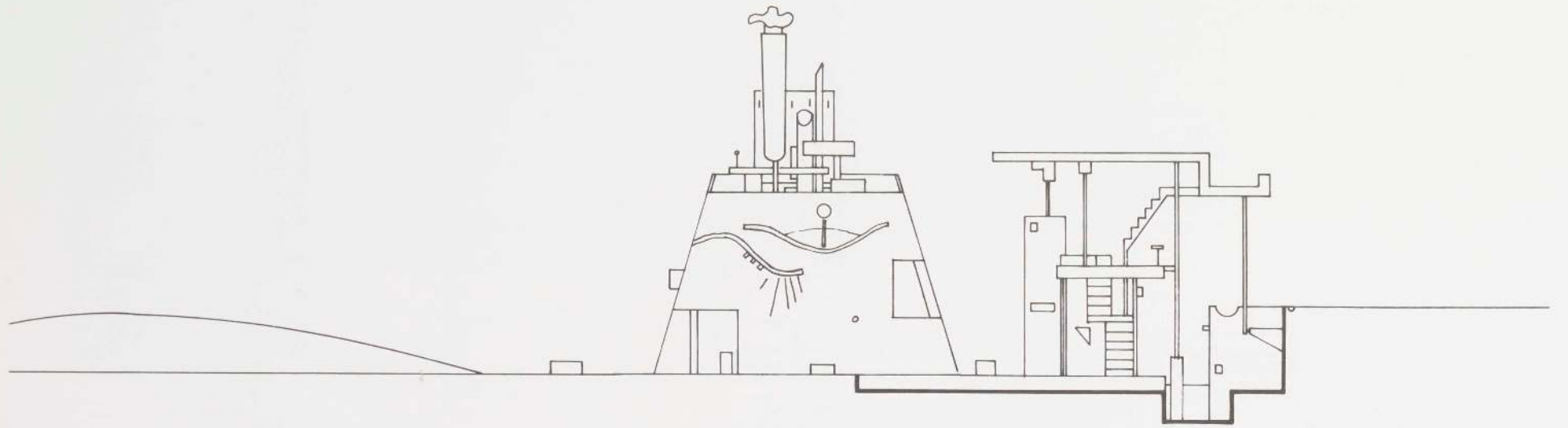

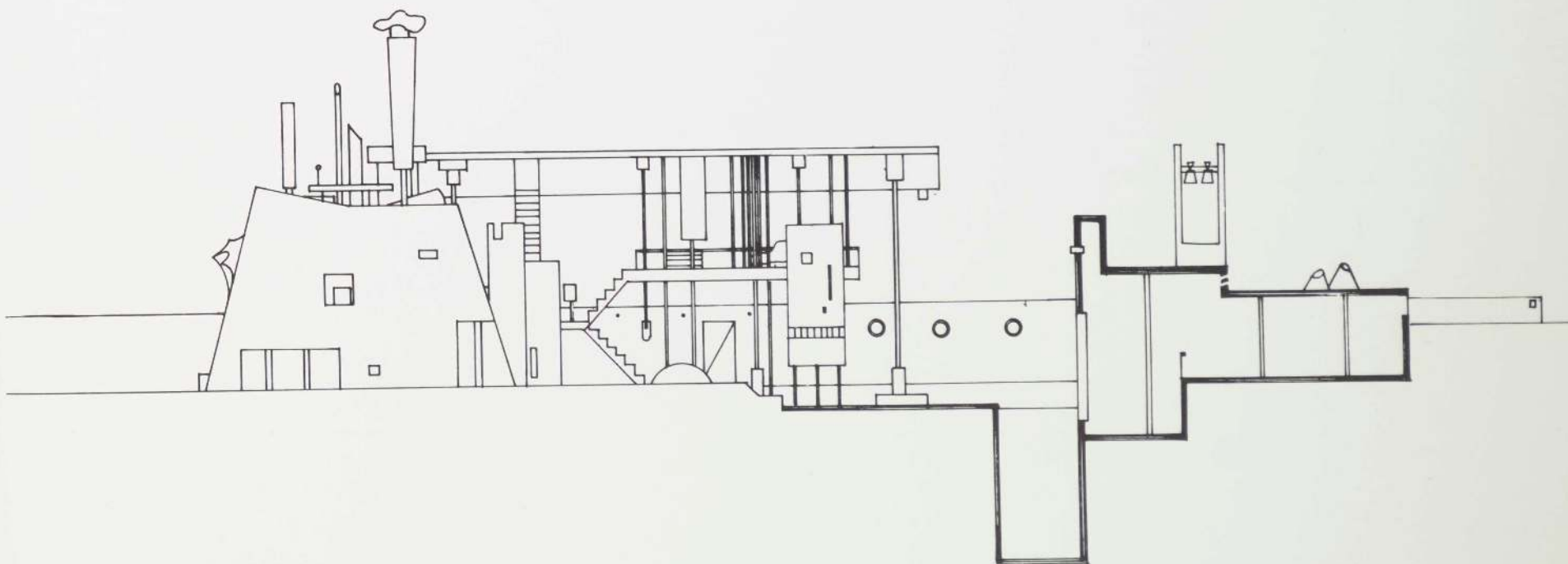
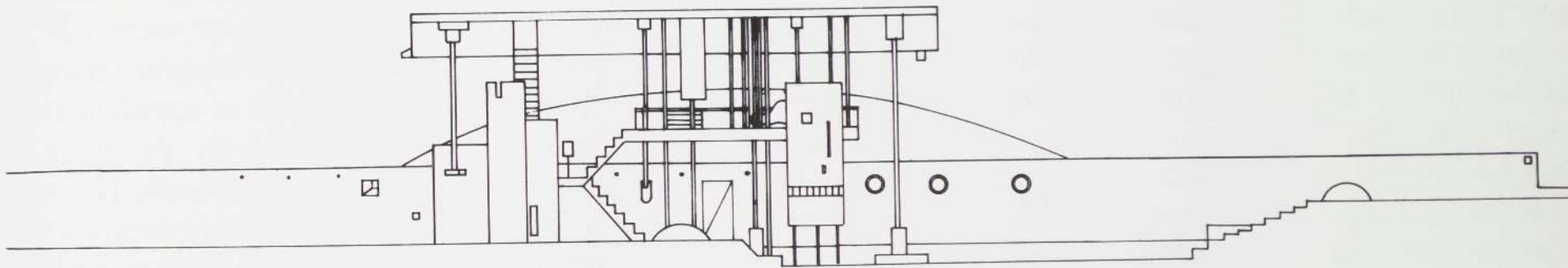

COLLAGE/DANIEL LIBESKIND. Collage challenges the notion of architecture as a synthetic construct—a mixture of various creative disciplines. The idea of achieving such a synthesis by a hollow manipulation of heterogeneous elements can result only in 'synthetic flaws'. Architecture cannot compete with film, total theater, technology, psychology, or sociology, to achieve relevance. By drawing from these motley disciplines it constructs only hybrid conglomerates without integral syntactic necessity or organic unity. The expedient definition of architecture as a 'total environmental system' is popular among designers, users, producers, critics, etc., because it allows the concurrence of all these points of view without provoking a conflict between them. The theory that architecture is a synthesis along Wagner's theory of the theater, allows and in turn justifies, the complete exploitation of any device; be it plastic, programmatic, or technical, in order to achieve a superficial stimulation of our sensibilities. In this way the accidental and arbitrary parade in the guise of a new methodology. The attempt at incorporating these foreign technologies or sophisticated mechanizations does not lead to dynamism of thought but rather to enervating physical mobility. Progress in this direction is therefore futile from the conceptual view, for no matter how much architecture exploits these resources, it will always remain inferior to a discipline such as film, for its ability to manipulate sequences, control speed, or create instantaneousness. The analytic approach, devoid of multiple means, limited to the existing materials, determined by historical realities, can fashion a new framework for concepts and ideas by releasing us from the determinism in both syntactic and semantic domains. It is a kind of poverty that is being proposed. A poverty of matter to be compensated by the development of the conceptual ideal. The use of 'garbage' reveals a possible method which can penetrate beyond the surface appearance of meaning and form, and strike at the very depth of conditioned relations; generating through a new grammar radically different ways of perceiving, thinking, and ultimately perhaps acting.

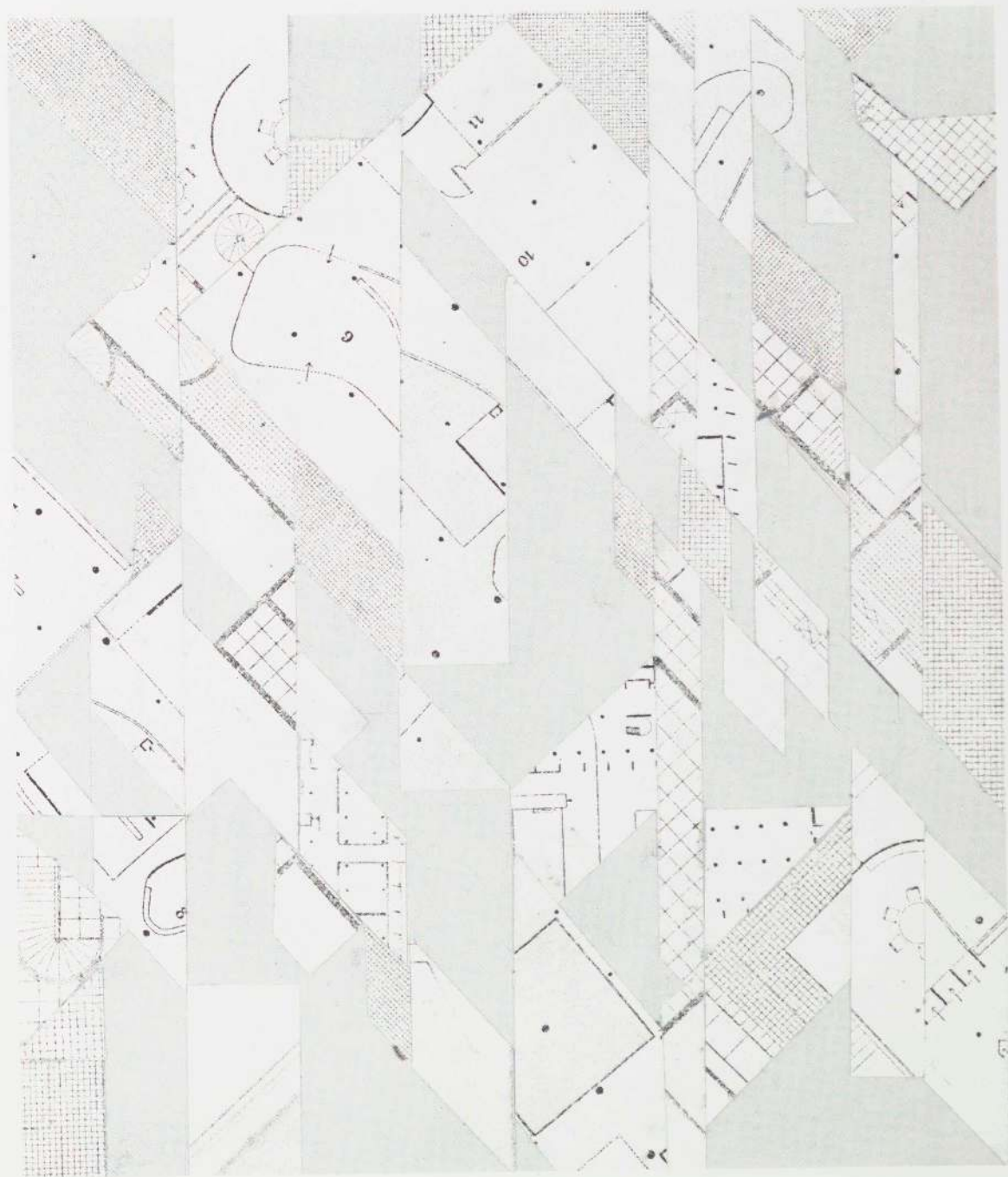

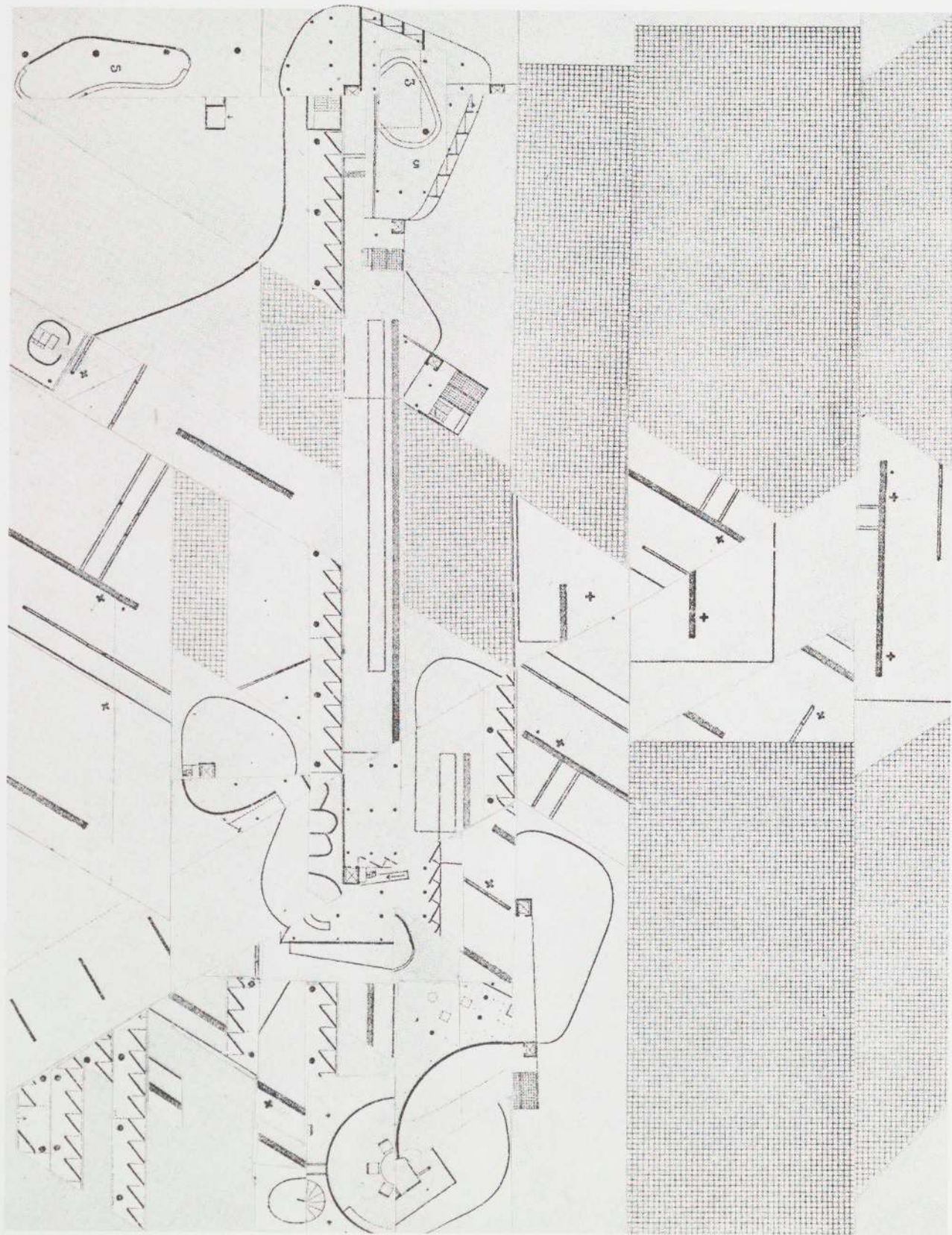

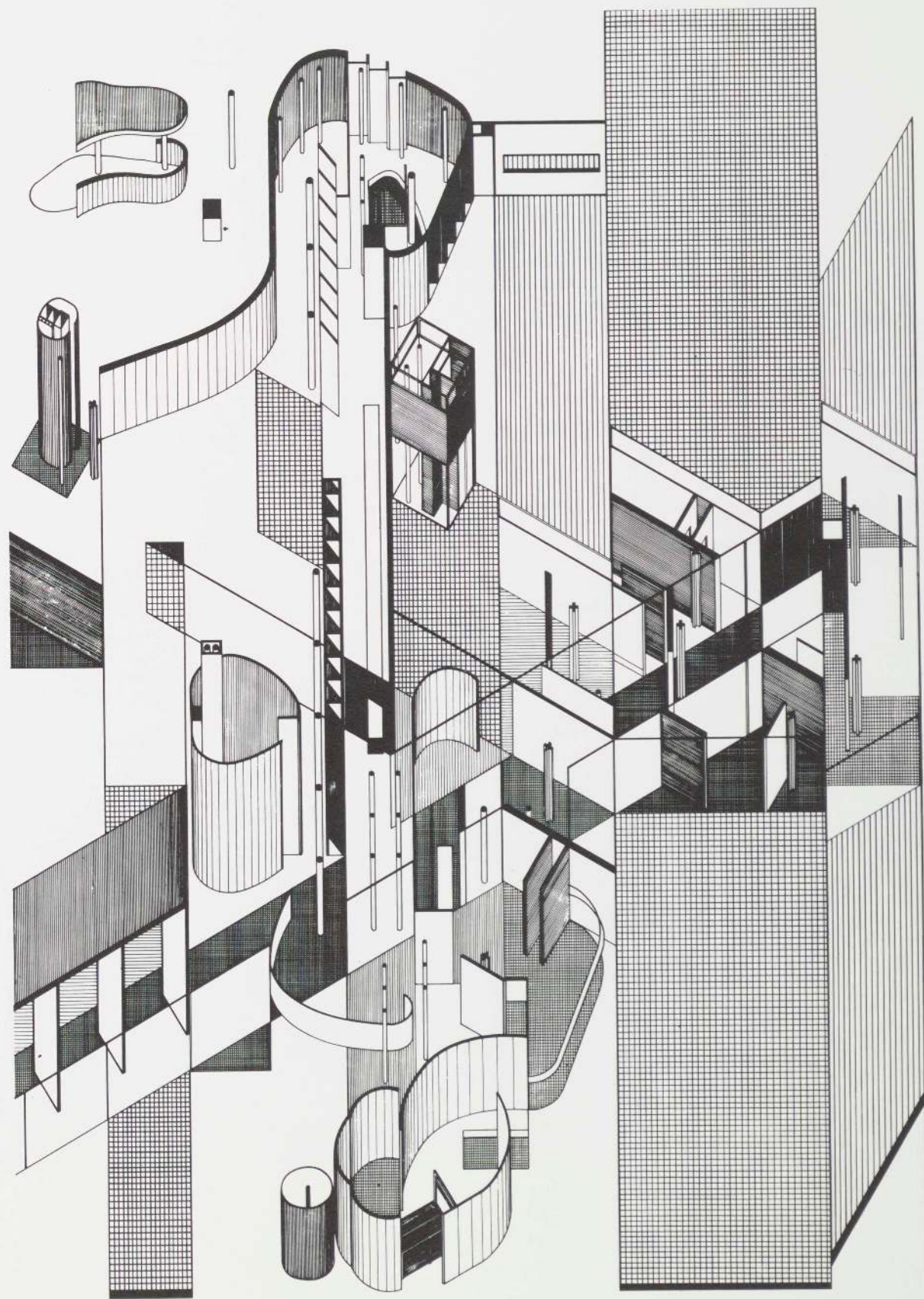

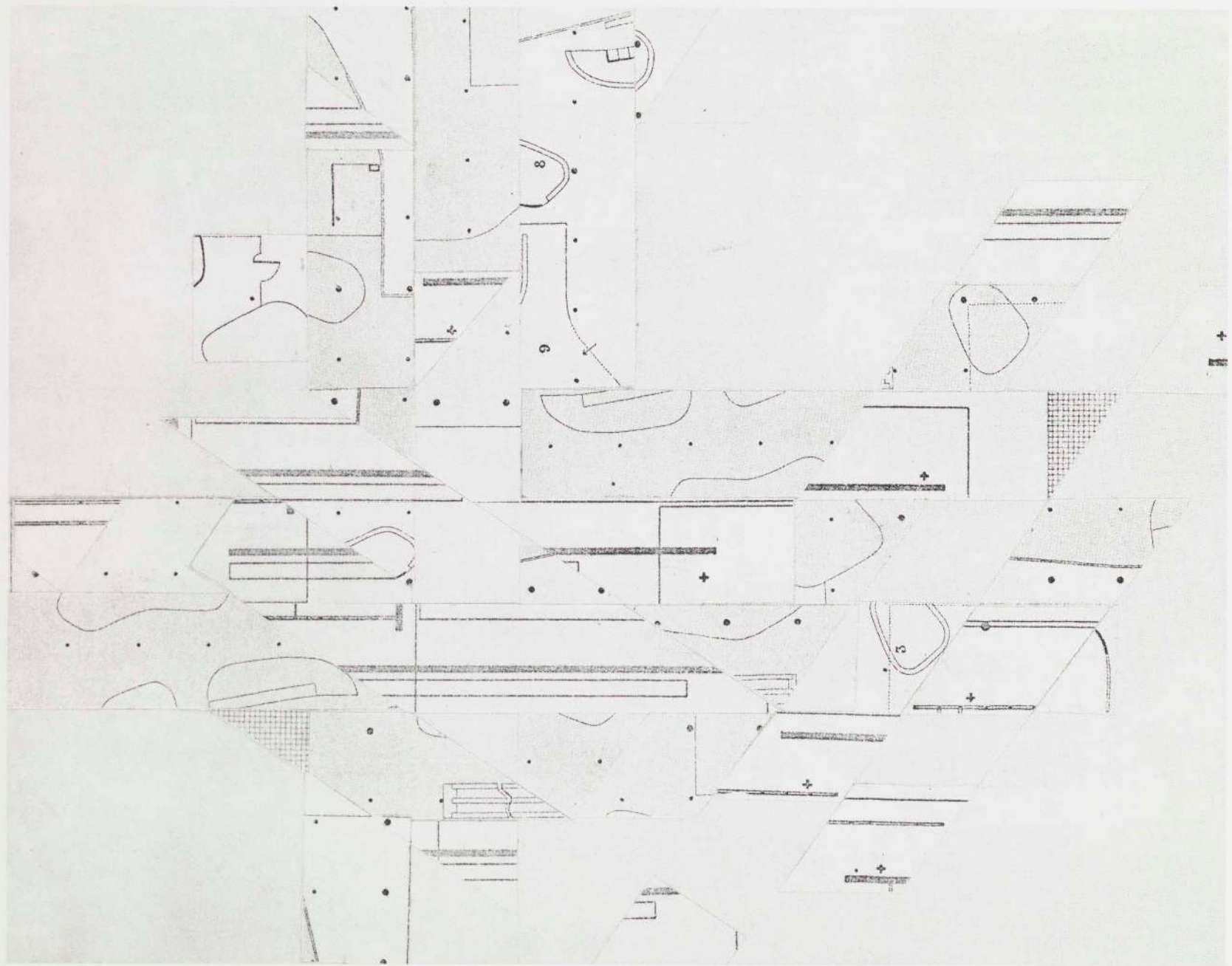

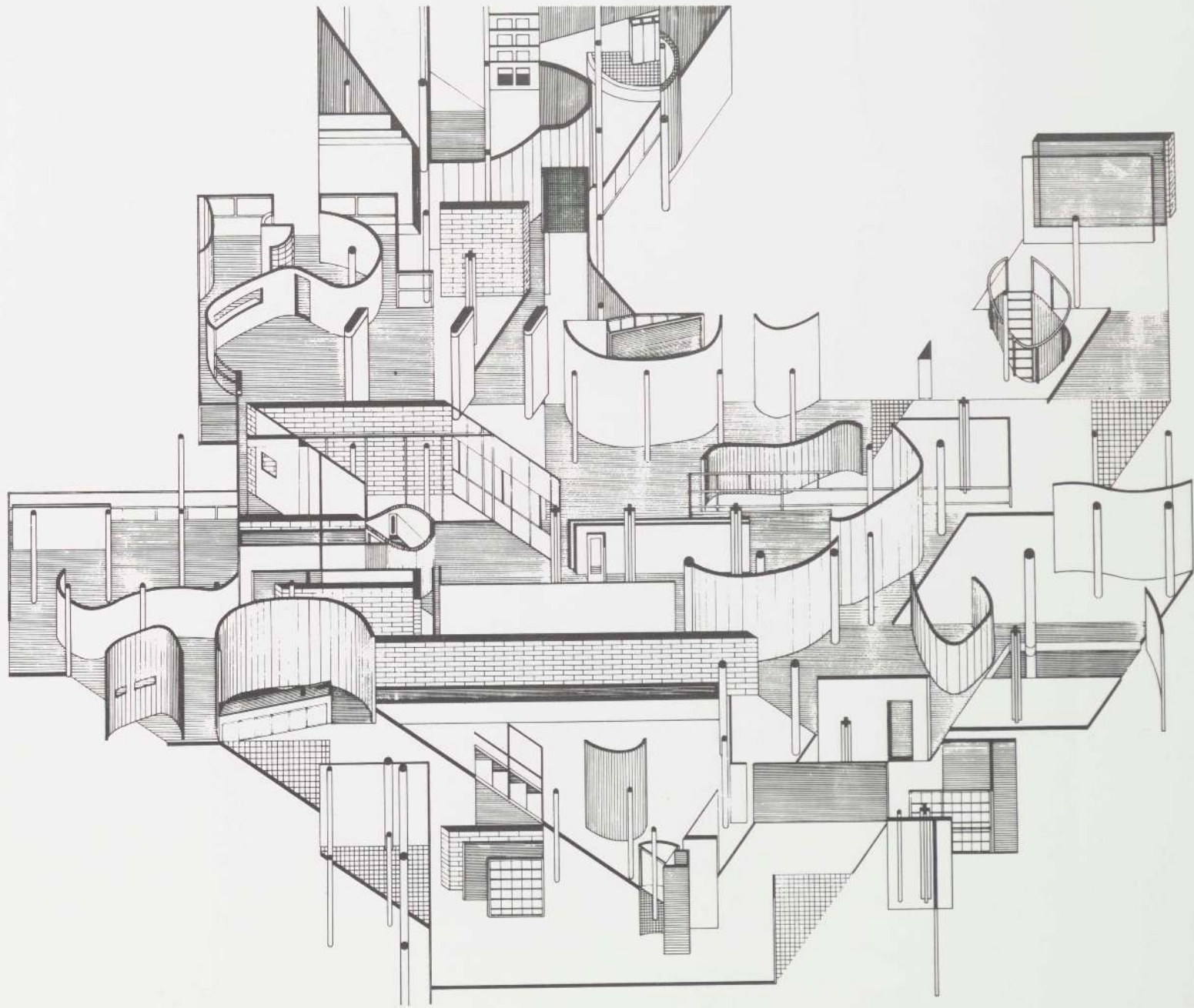

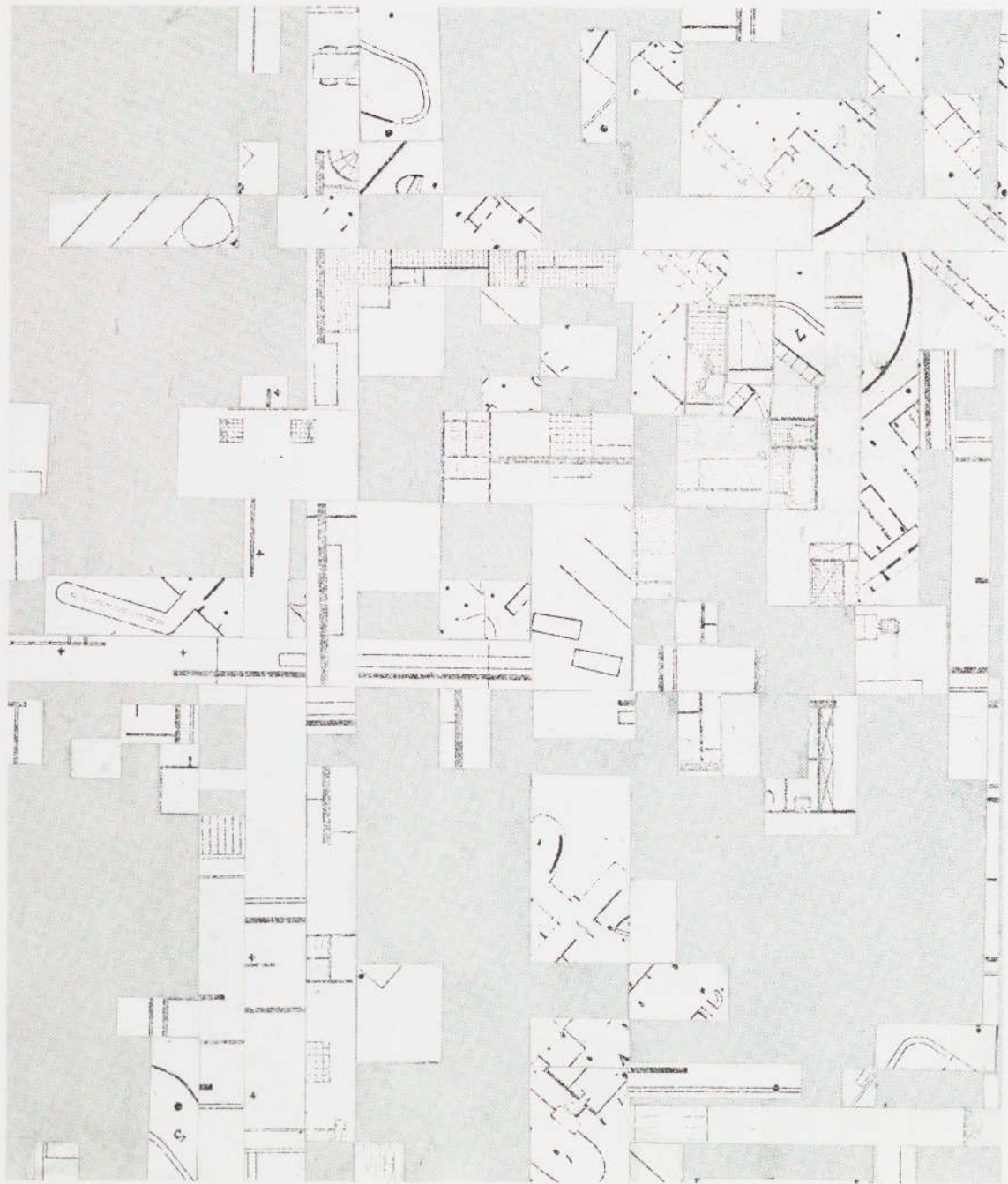

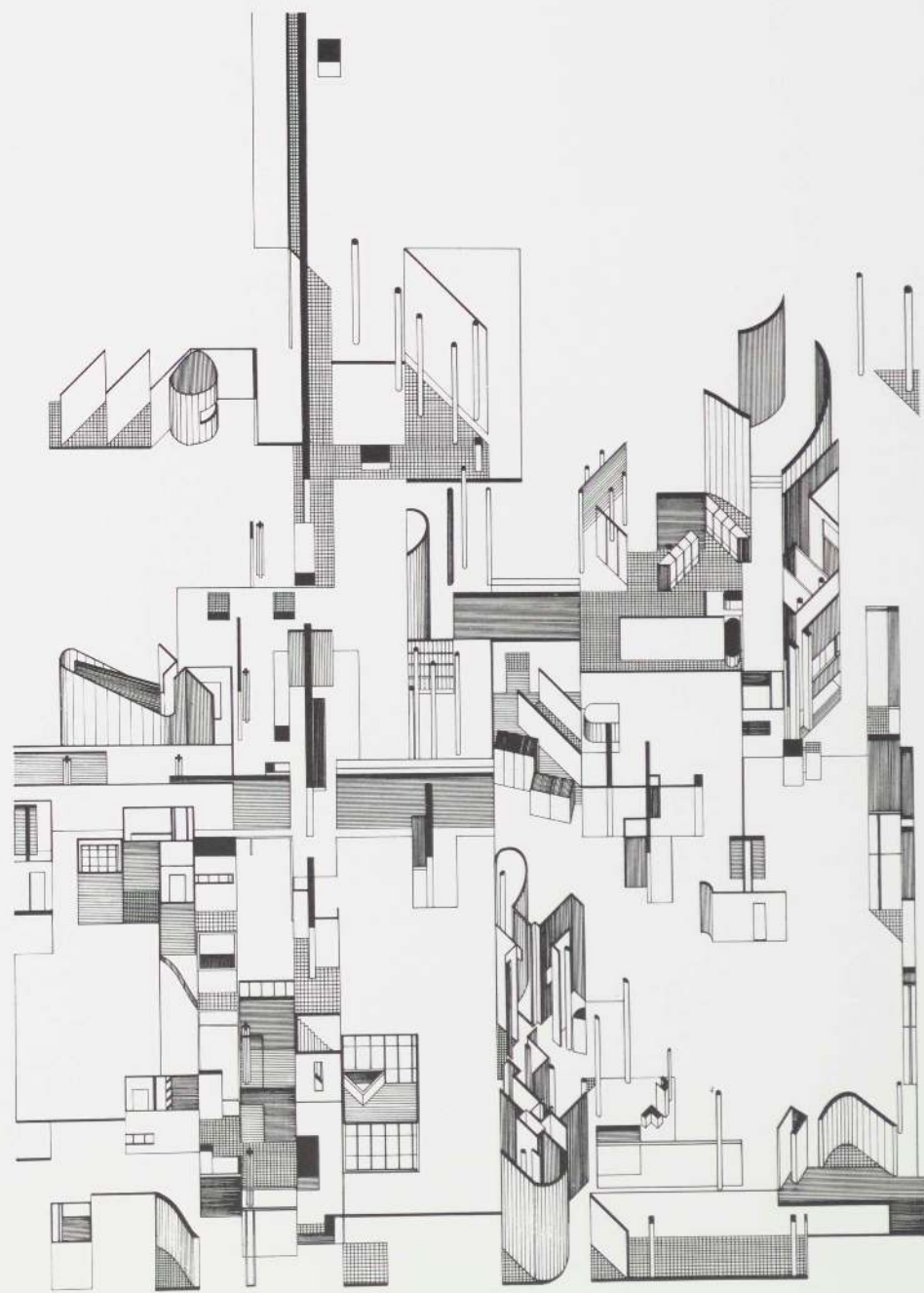

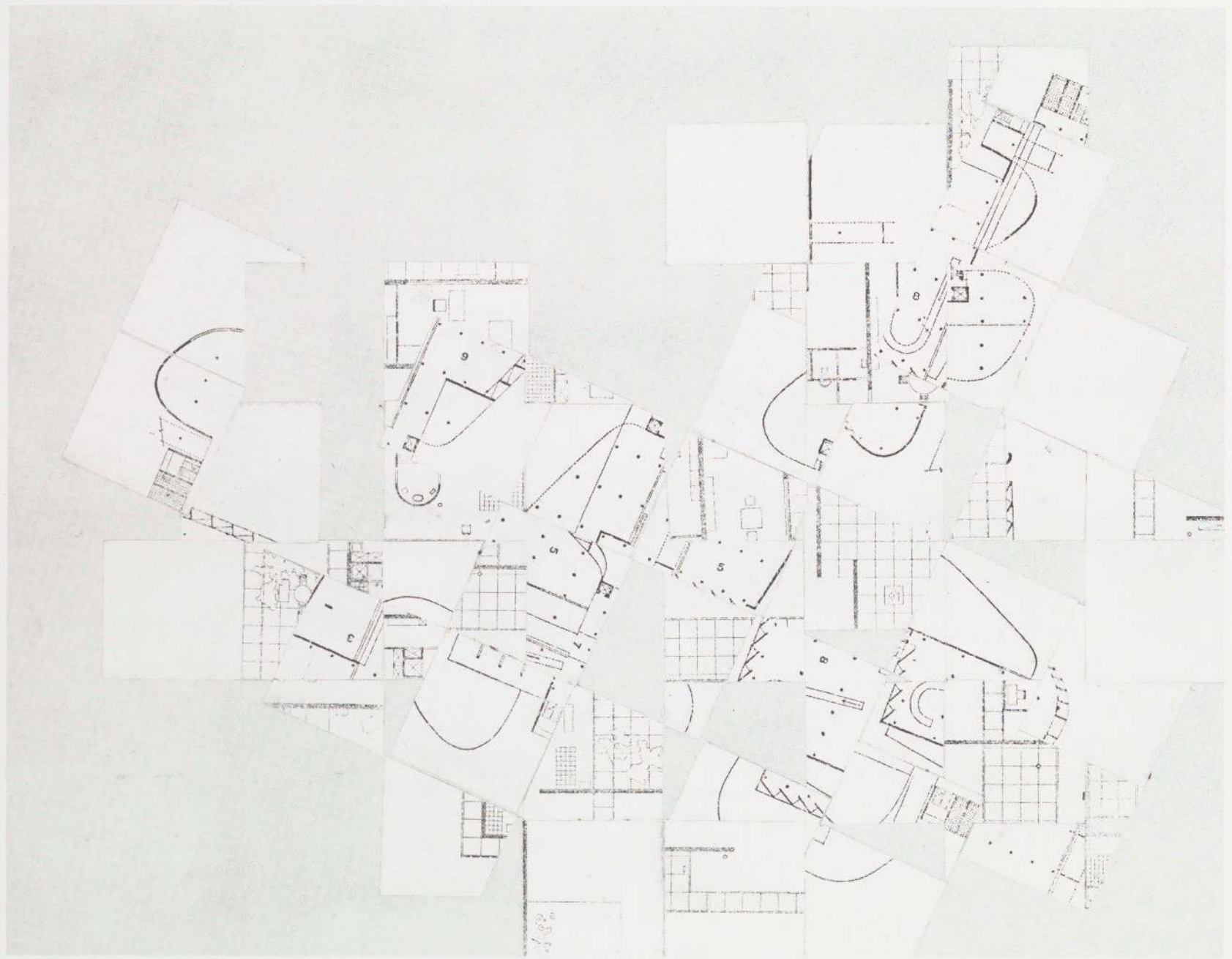

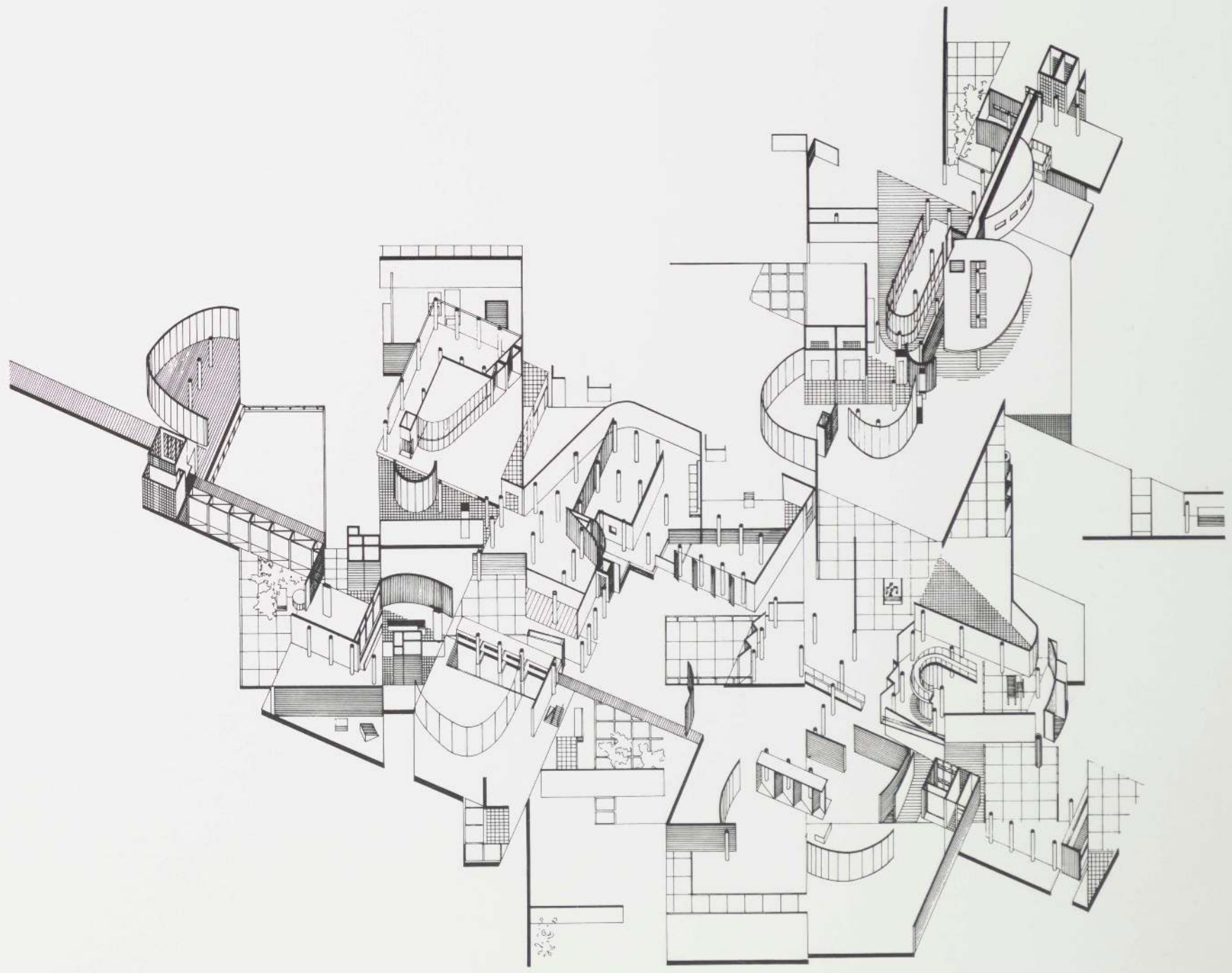

GARAGE-RAILROAD STATION/LAWRENCE PHILIP WITZLING. It was the intent of this design to: a) examine the alternative patterns of organization and movement of drivers and pedestrians; b) produce the formal styles which can meaningfully reinforce and exploit these patterns; c) see if such a building might provide a positive experience within the set of large-scale commuter facilities. (The garage was intended to serve ten thousand vehicles.)

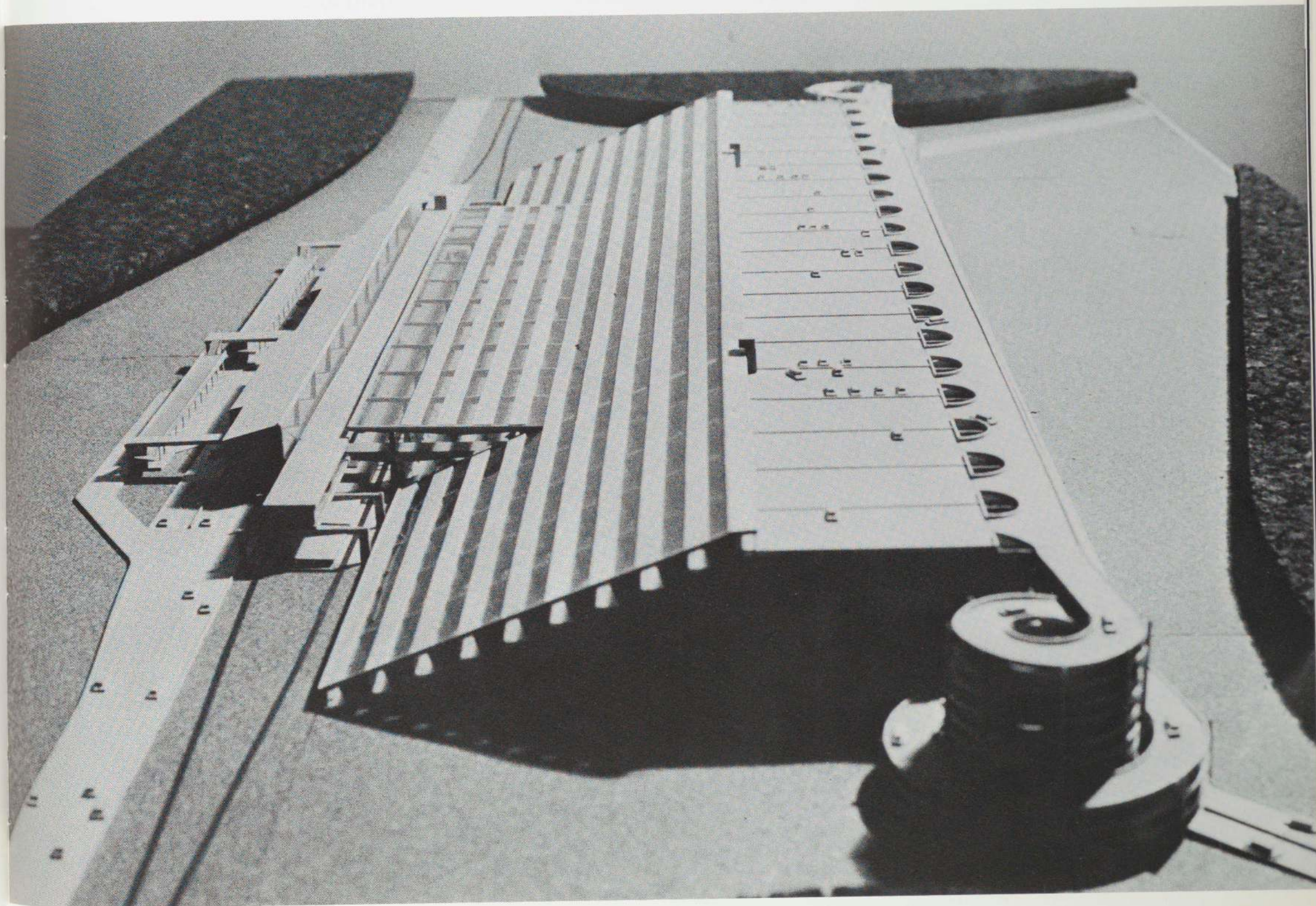

THESIS/ALFONSO RODRIGUEZ. The building expresses in its form and structural elements the wind and gravity forces that act upon it. Bulk and height do not necessarily go together. The solution suggests that a structure can be large without becoming oppressive, playful without becoming arbitrary, respect economic realities without succumbing to them, and seek beauty without resorting to cosmetics.

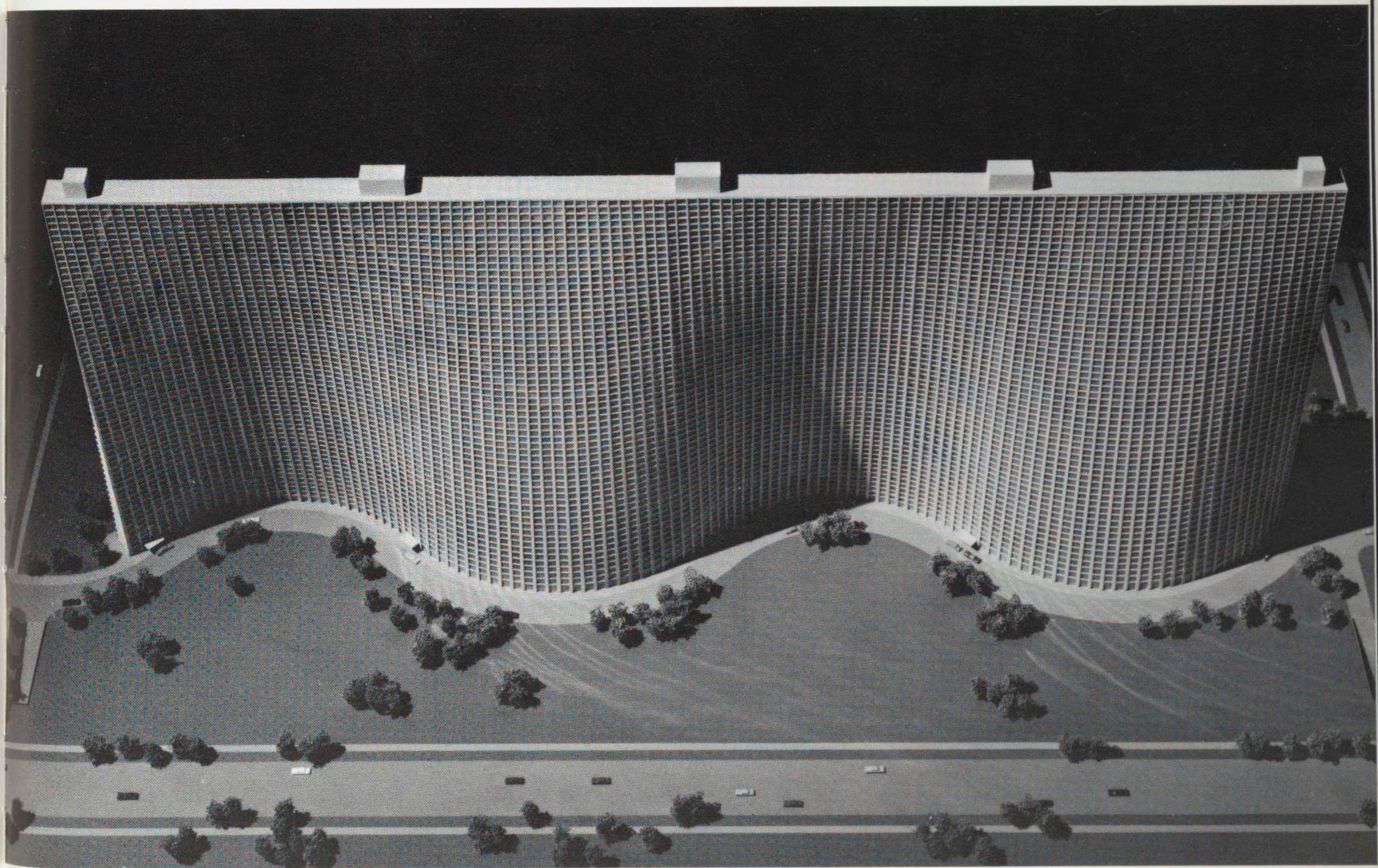

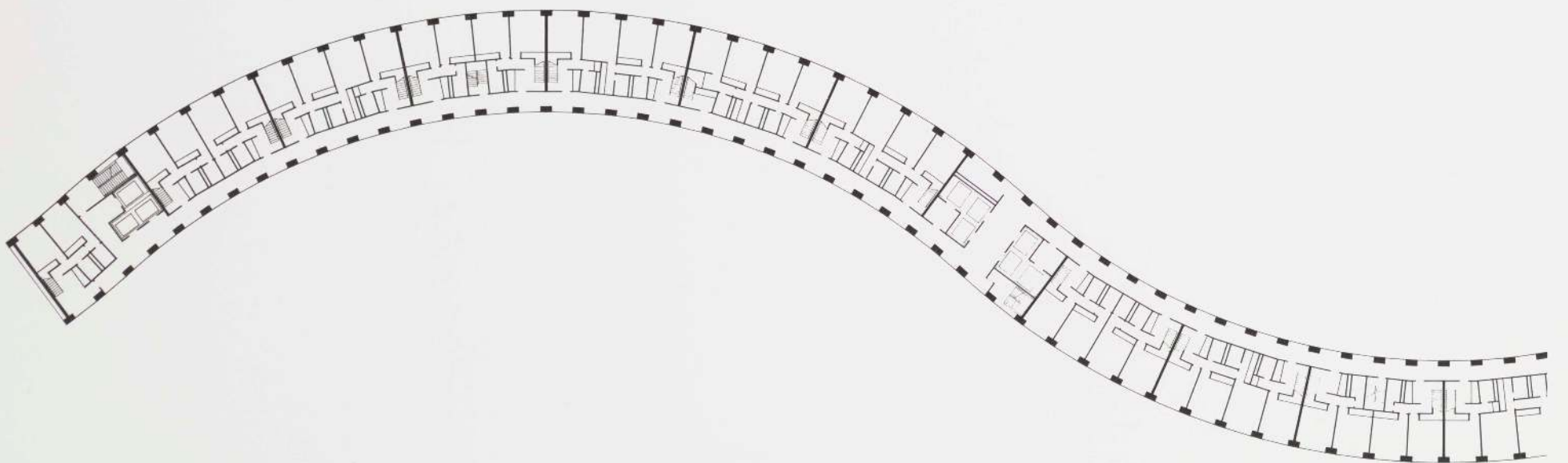
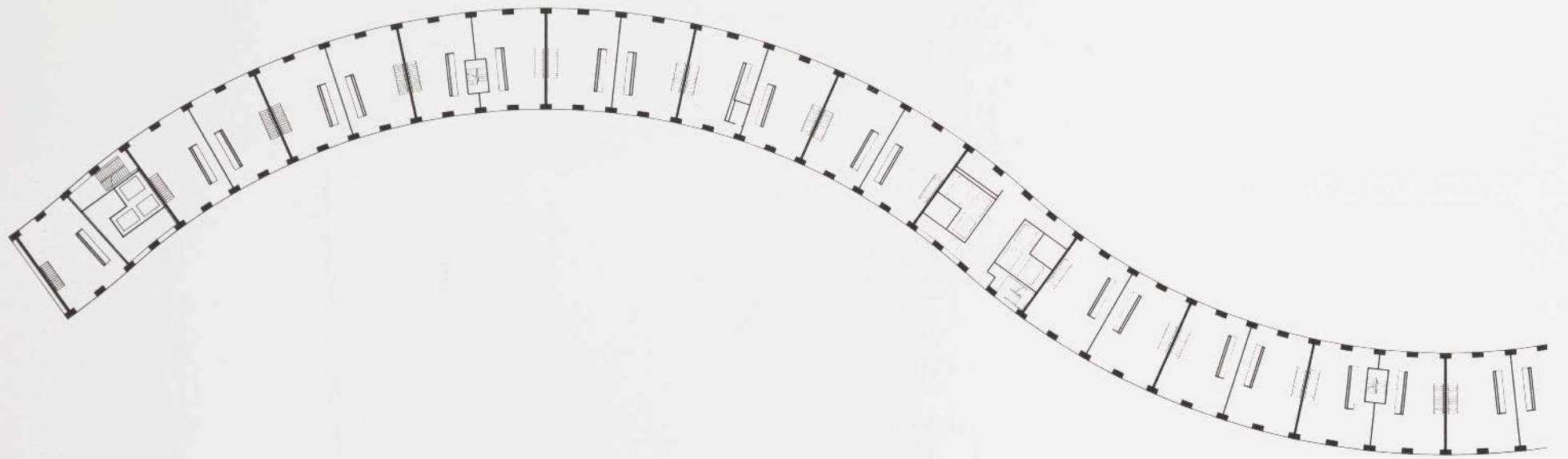

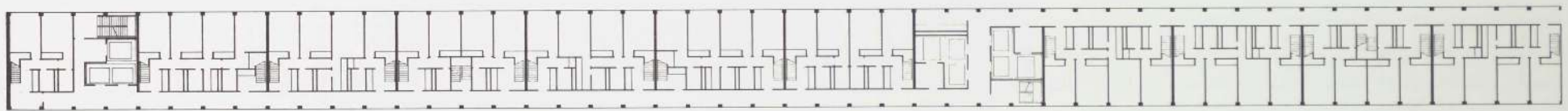
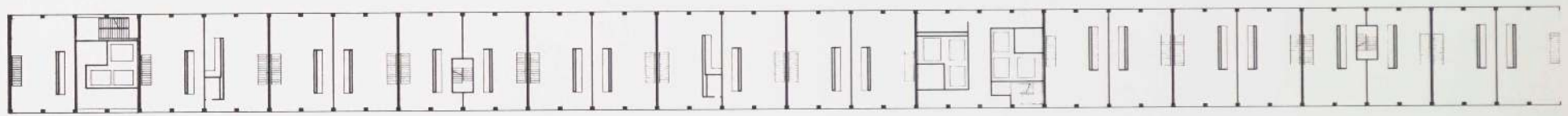

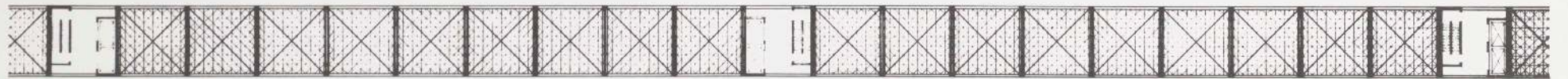
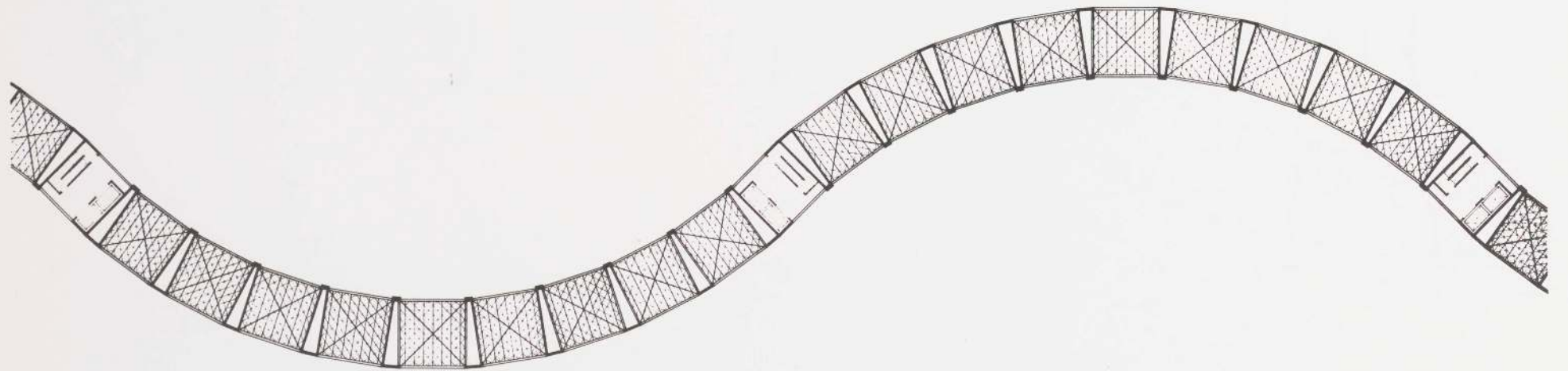

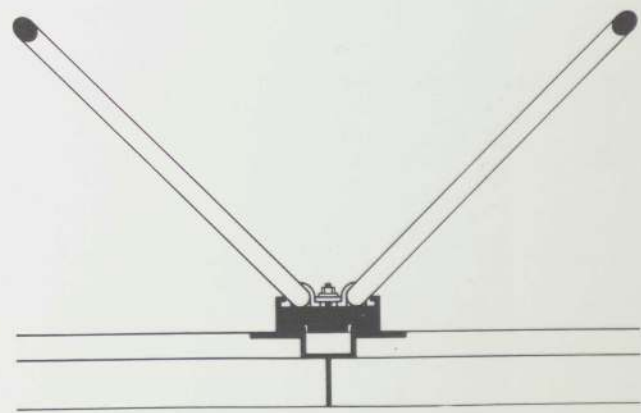
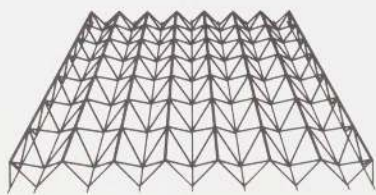
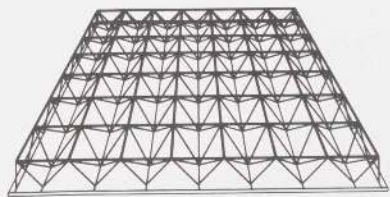
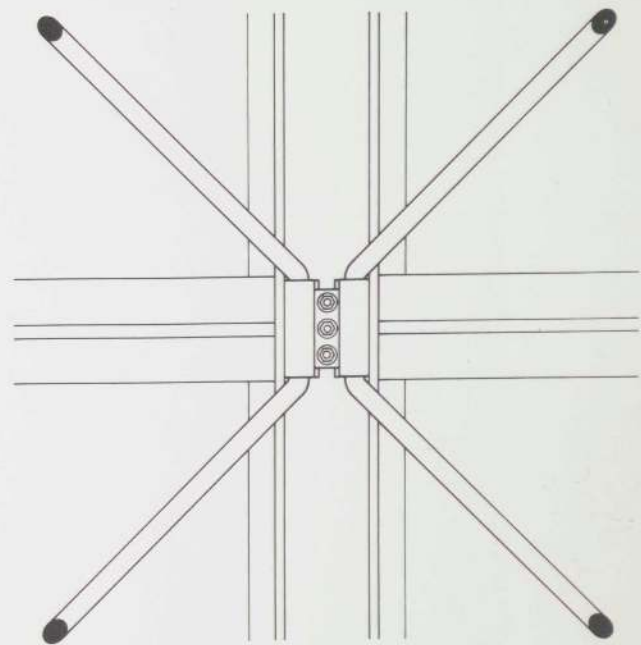
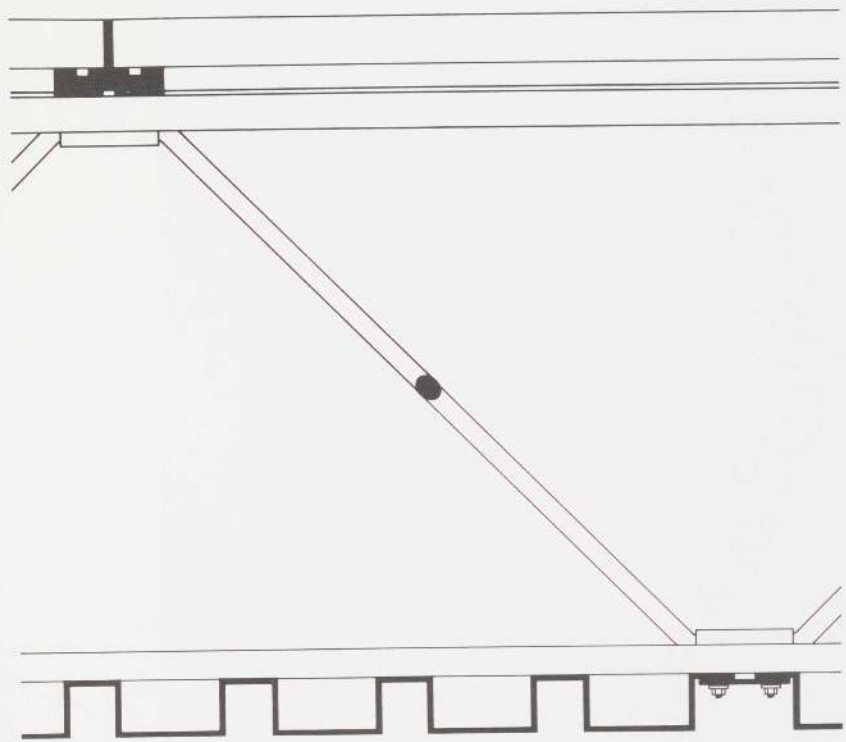

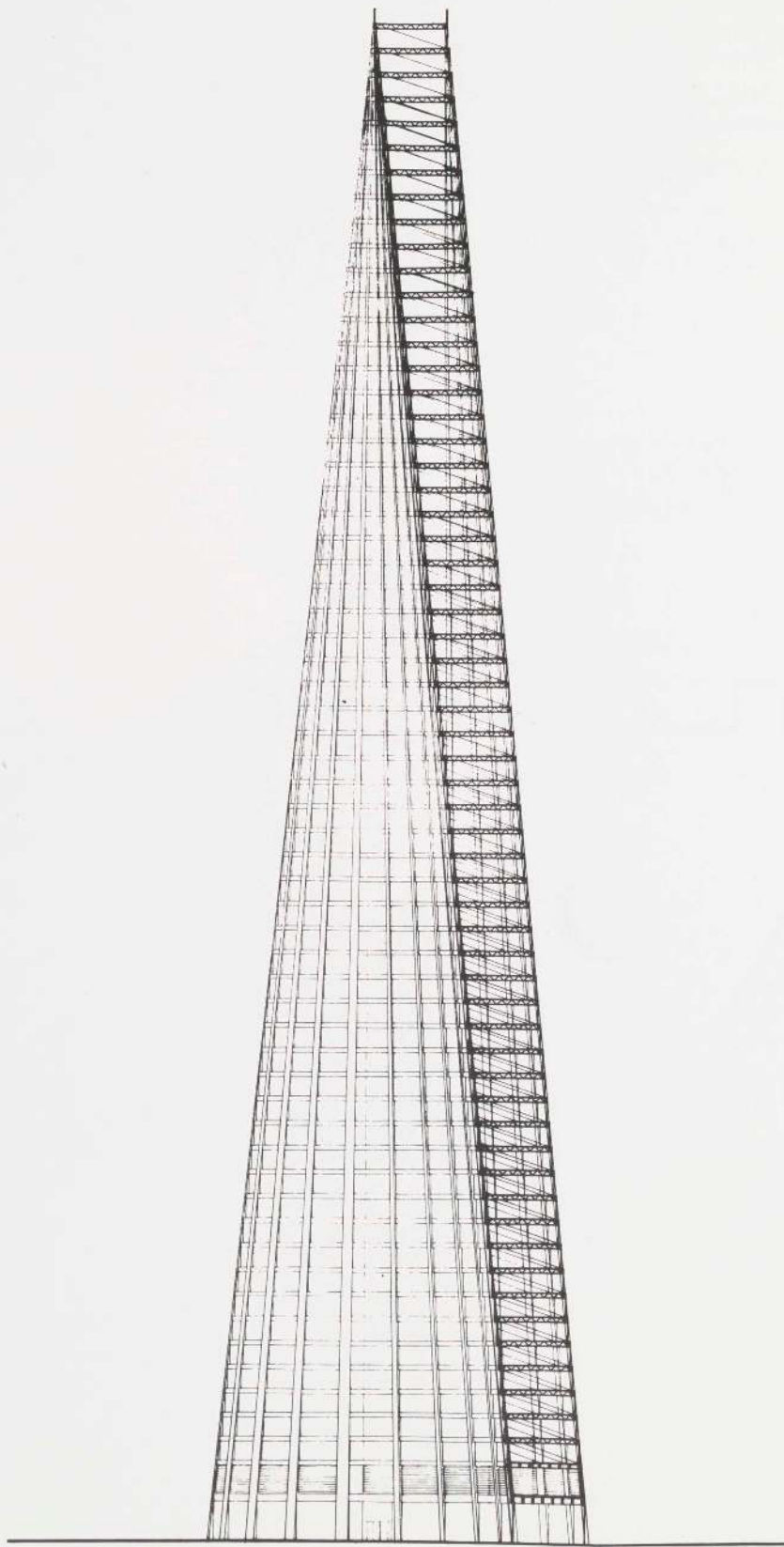

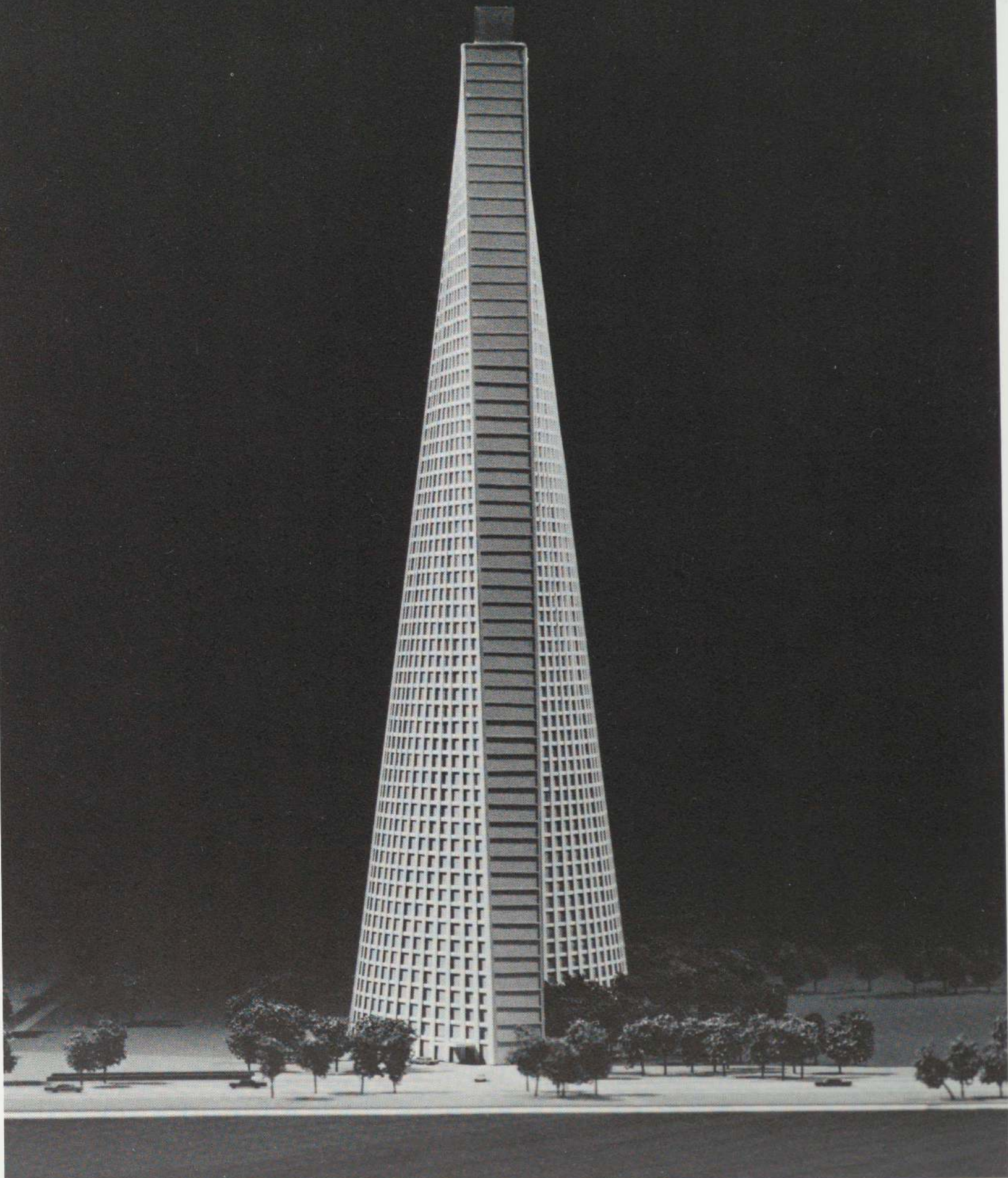

ARCHITECTURAL MUSEUM/NICHOLAS SCHNEIDER. A simple loft building the guts of which are smeared across its facade; a collage of mechanical and programmatic components trowelled up into a mural; quite literally, a huge cavity wall.

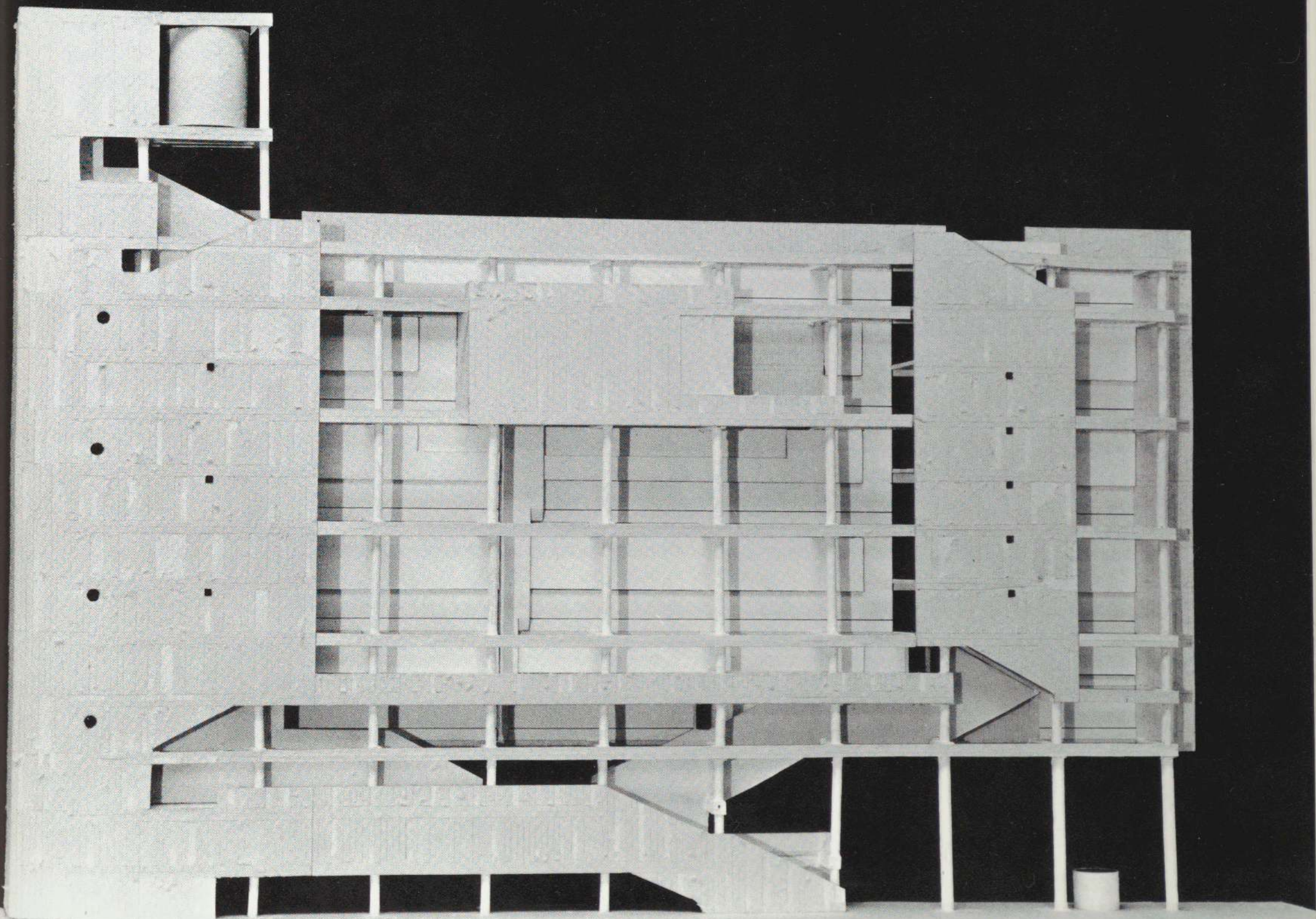

A TWENTY-SEVEN FOOT CUBE/PETER SALTINI. A problem stated as 'design a twenty-seven foot cube' was suggested as a thesis project. Traditionally, a program such as a residence is selected and the design proceeds using the cube format. This project takes exception to such a method. The study was based on the premise that procedure is of primary importance in design. Varying levels of complexity and different building types may be accommodated not by a procedural change, but by applying the appropriate program requirements. It was intended that the distinctions of form and function should not exist in the process, but instead that the process should consist of three simultaneously occurring systems: spatial, structural, and environmental. Although a specific program might require more extensive development of only one of these systems, they are all equally important to a final visual product. Another intention of the study was to evolve a program, working first with purely conceptual ideas and gradually satisfying requirements of detail. When a specific program is the primary step of the design process, it is followed by a complete set of preconceived conceptual notions. By working without a program it is possible to eliminate preconceptions, thereby enabling the development of purely spatial concepts. Rather than using the cube in its static form, the twenty-seven foot dimension and the three-dimensional diagonal plane were used to develop a sequence of spatial distortions. As the process continues, structural and environmental concepts contribute to the sequence. In some cases spatial concepts are developed from these structural and environmental concepts. A very important point is that all these considerations are so inter-related as to produce one continuous process.

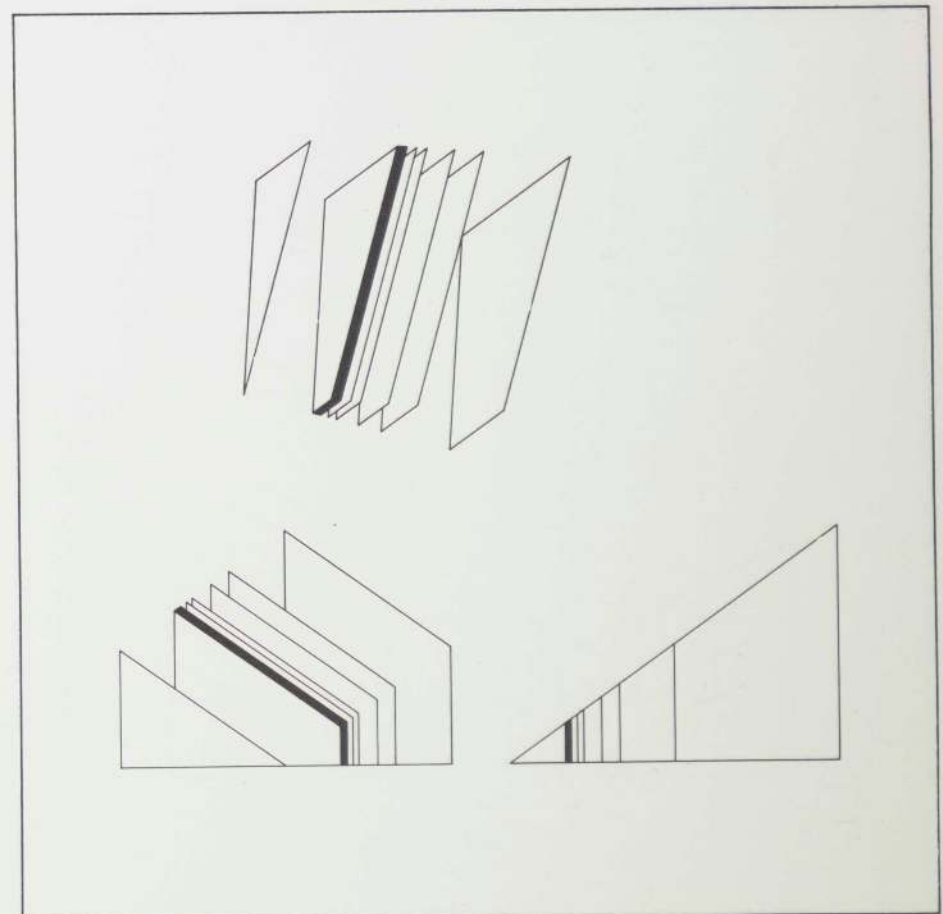
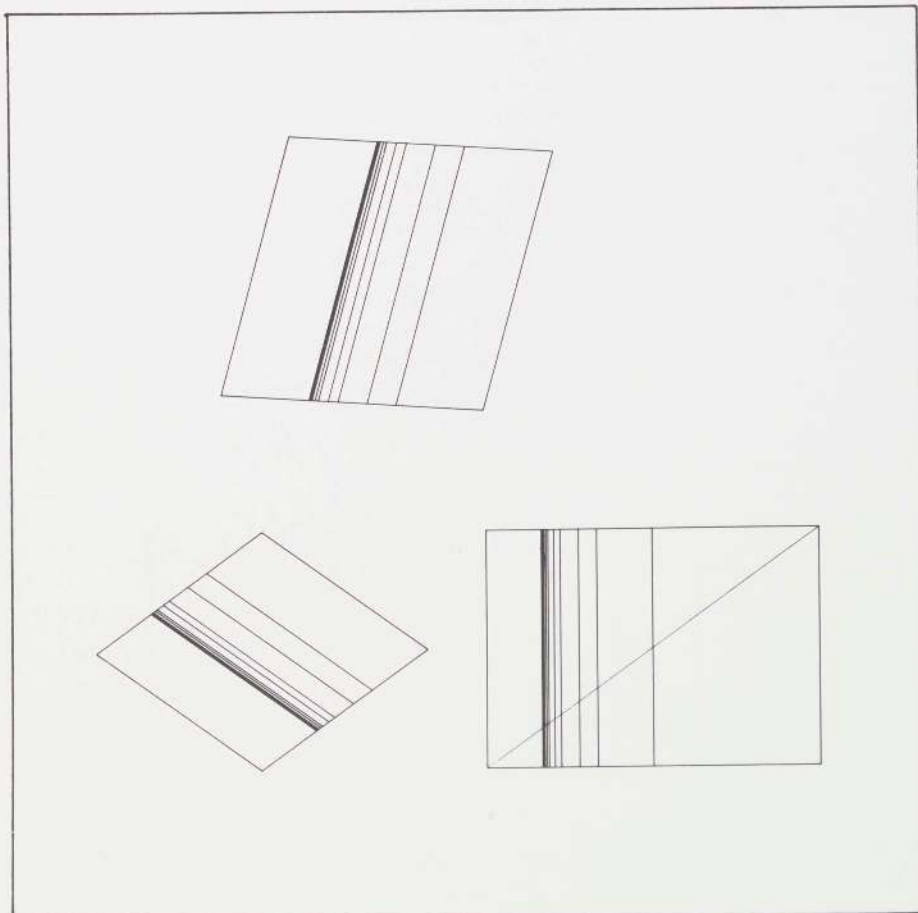
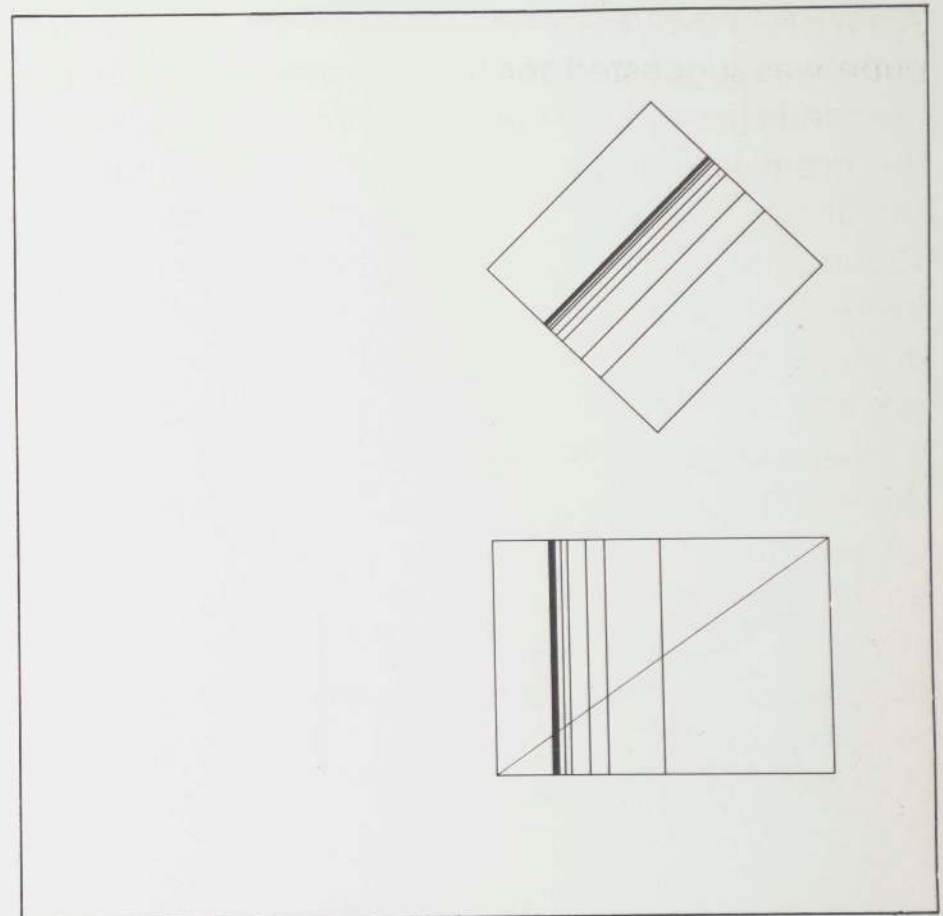
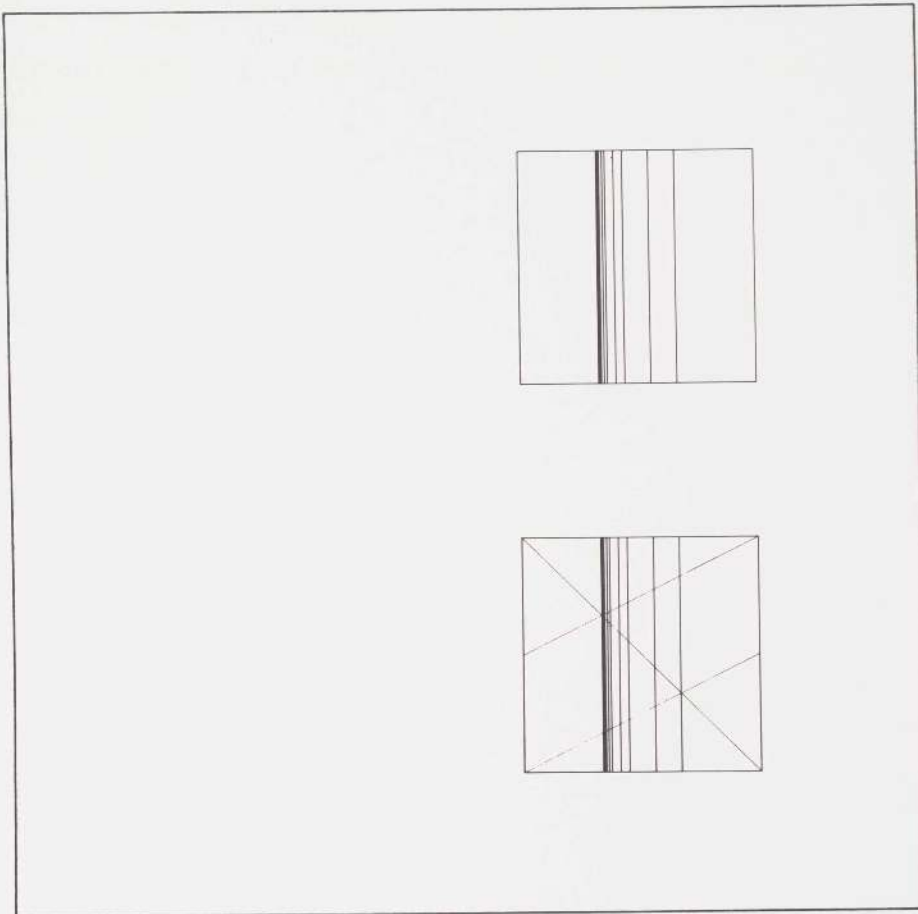

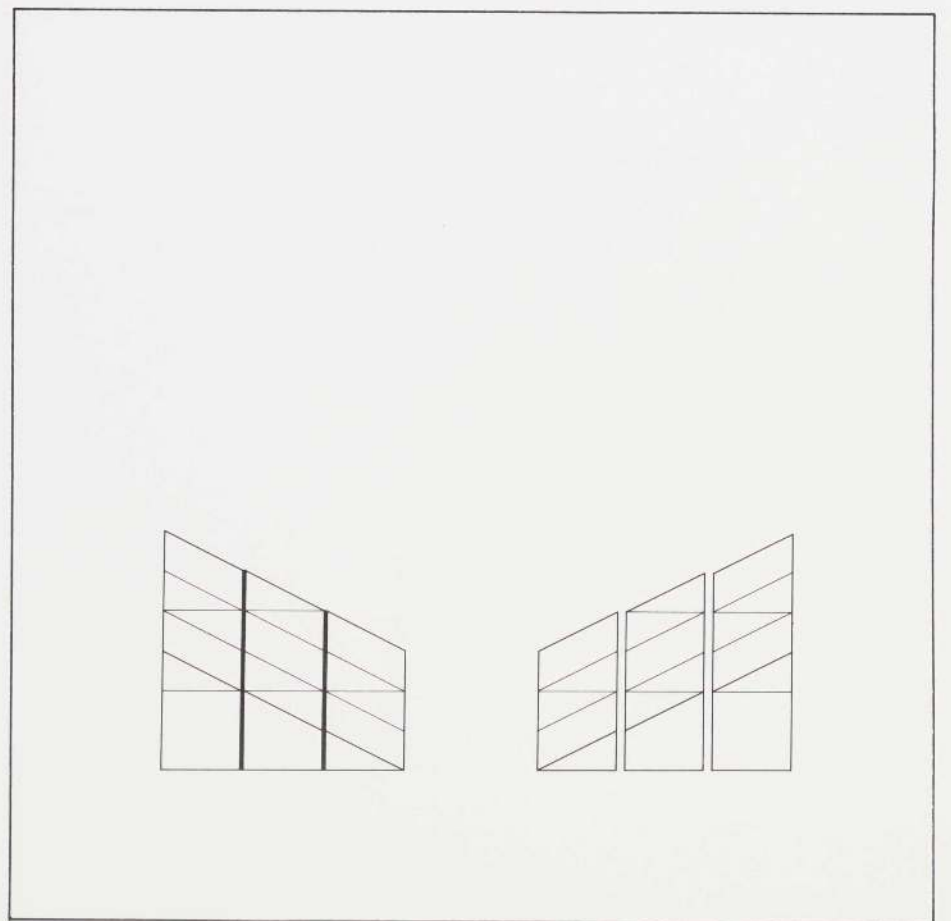
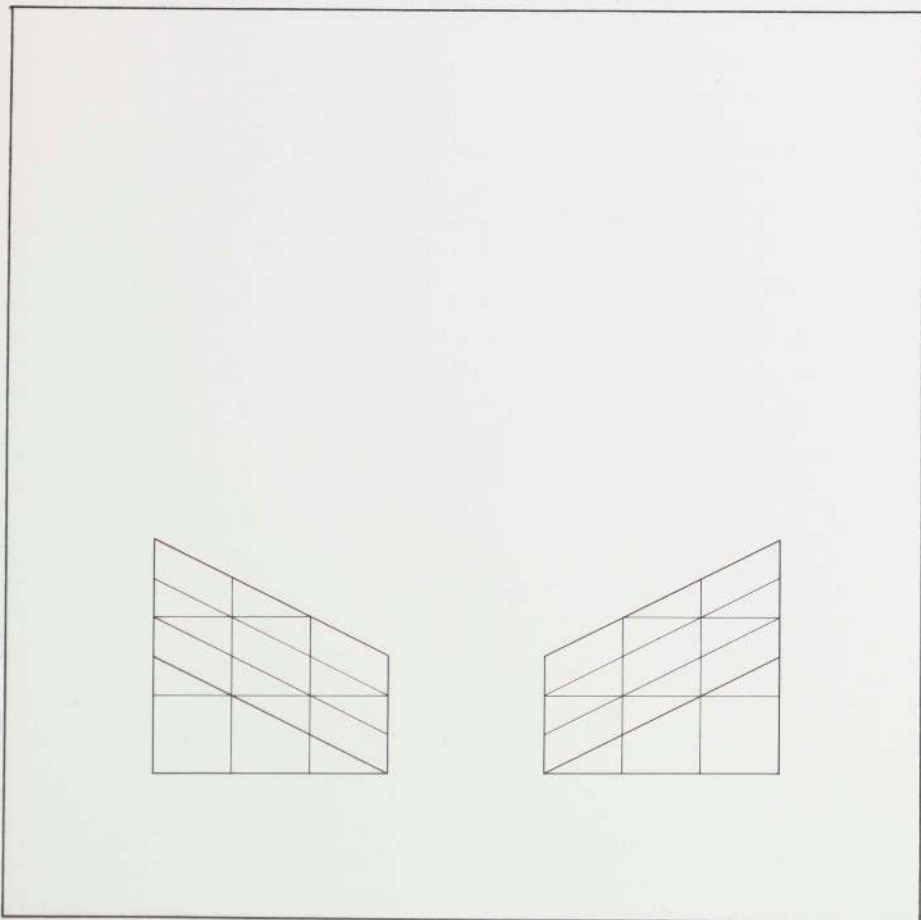
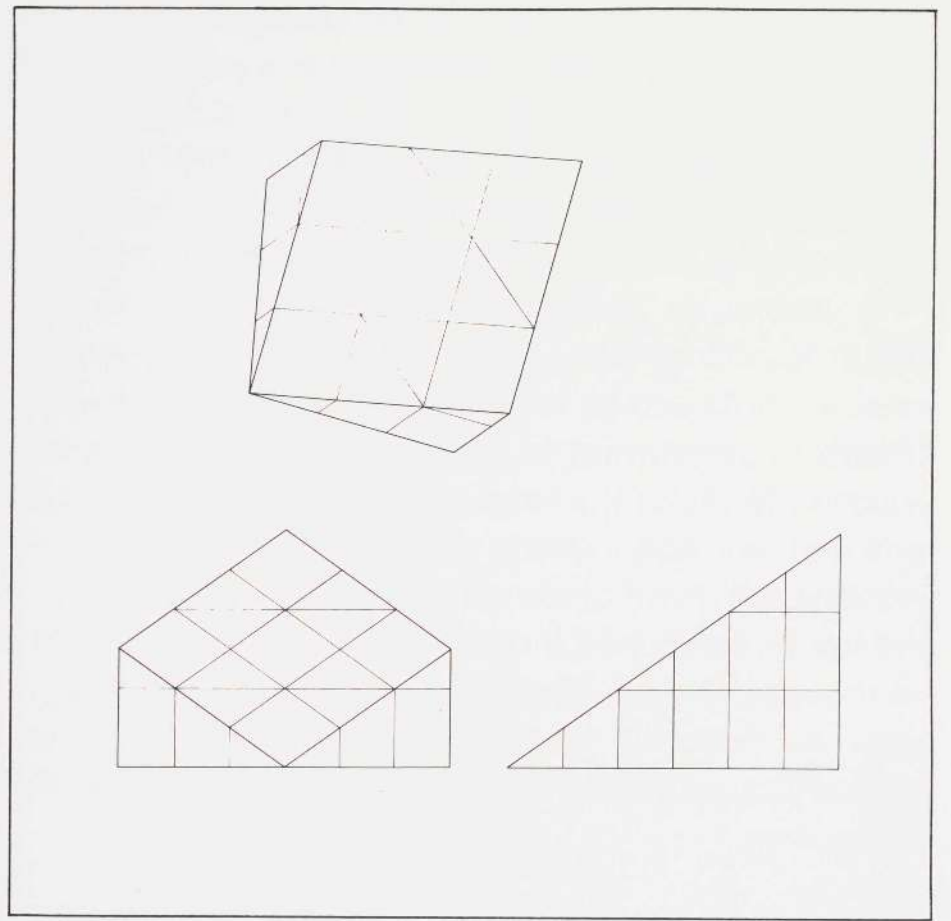
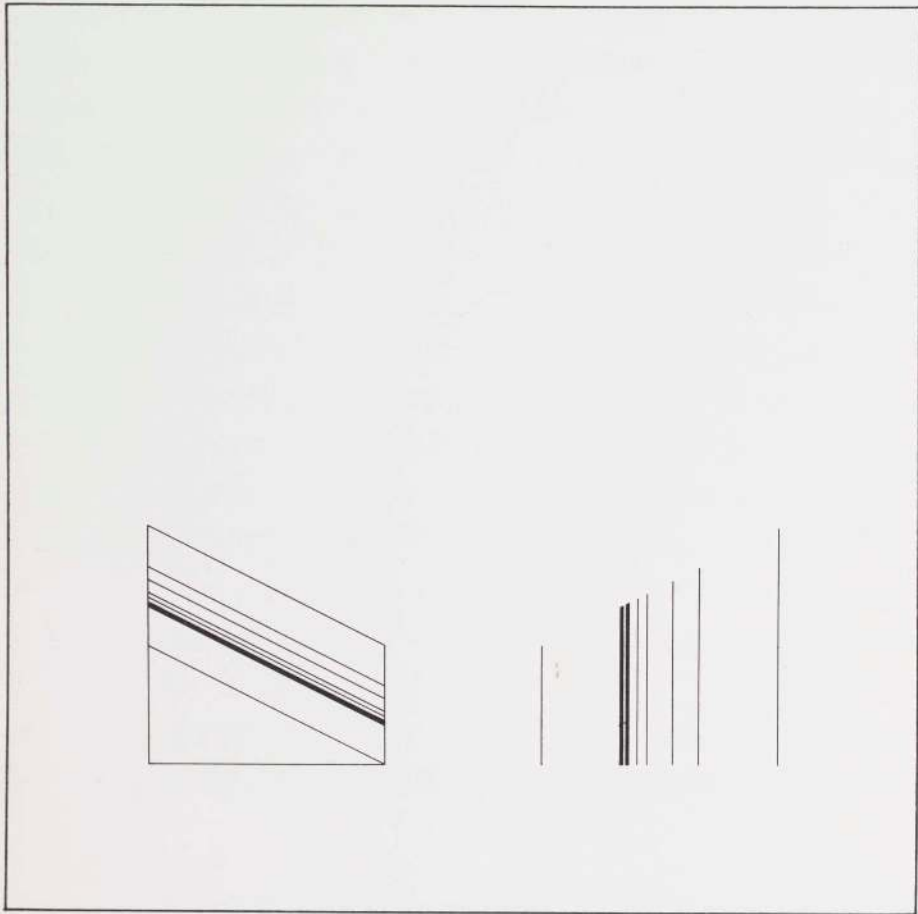

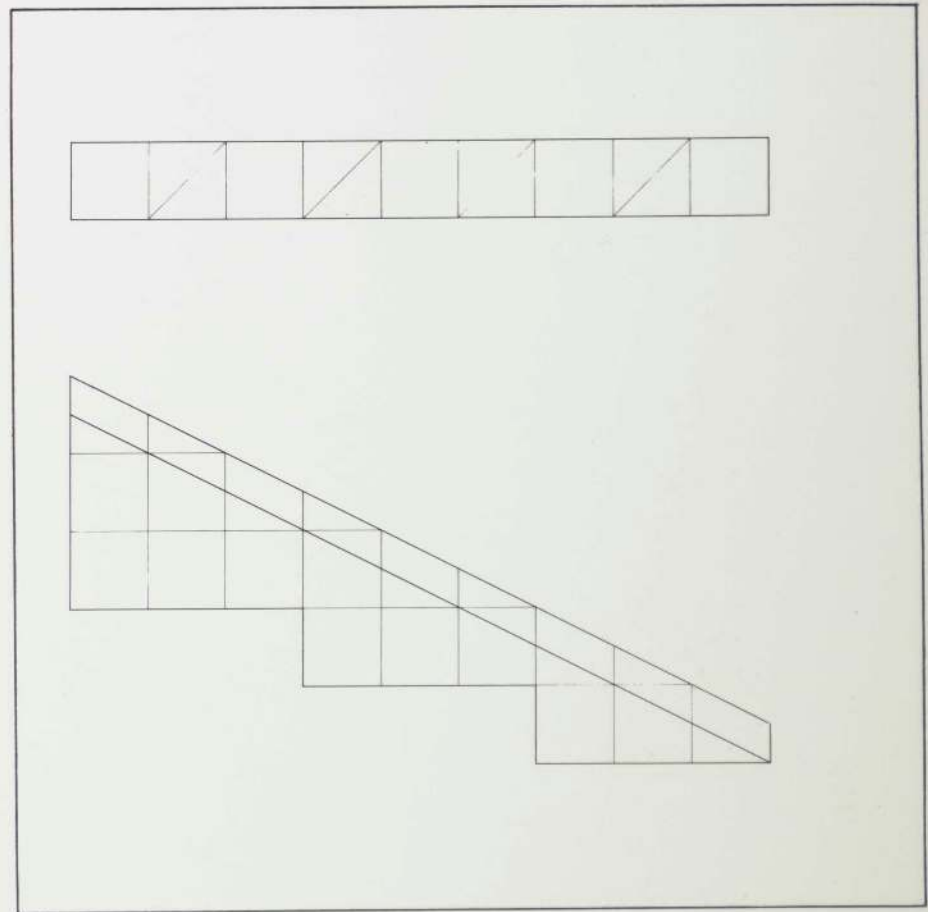
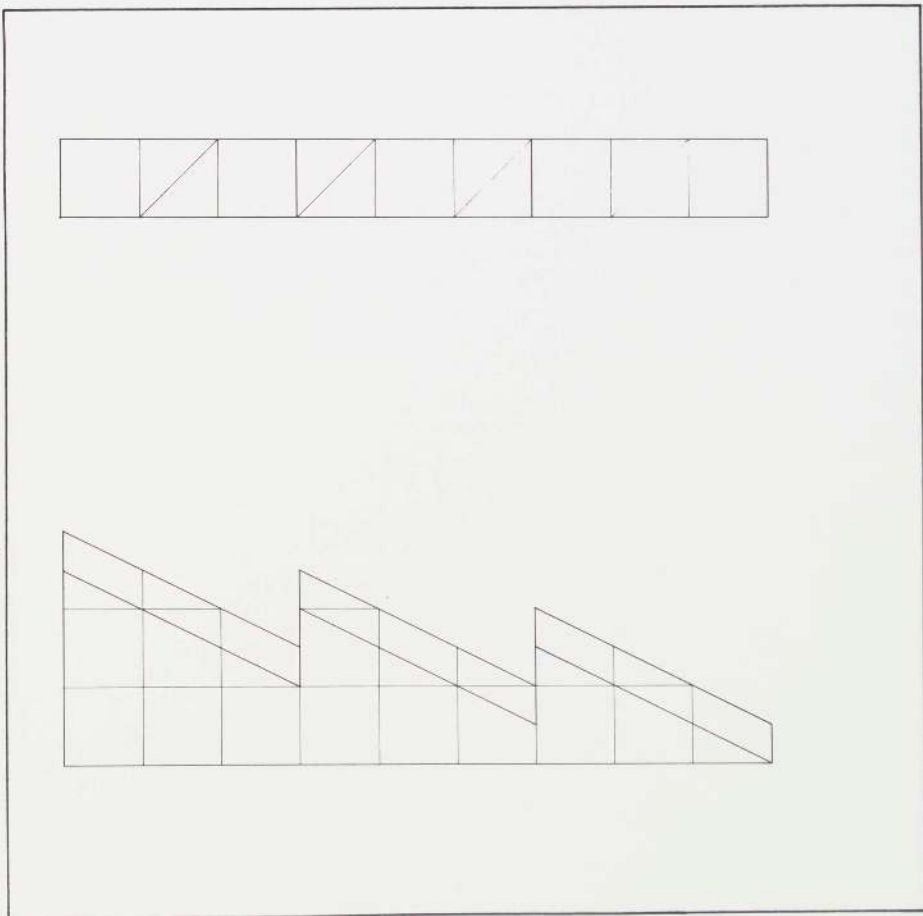
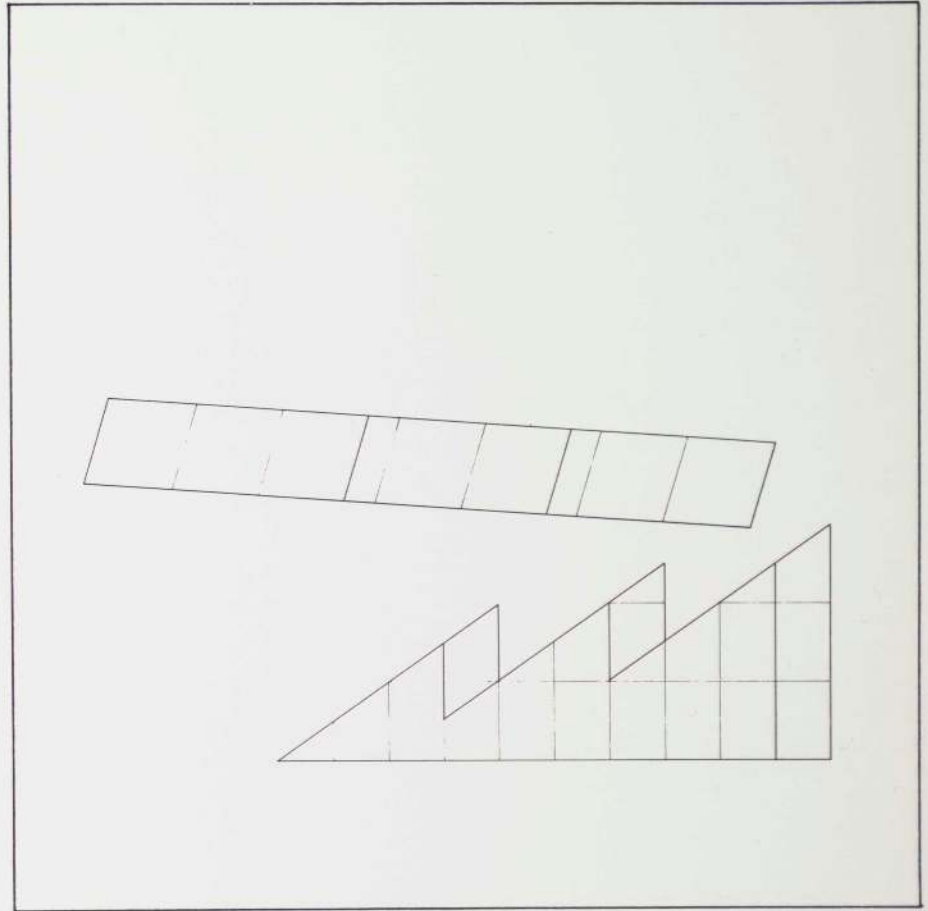
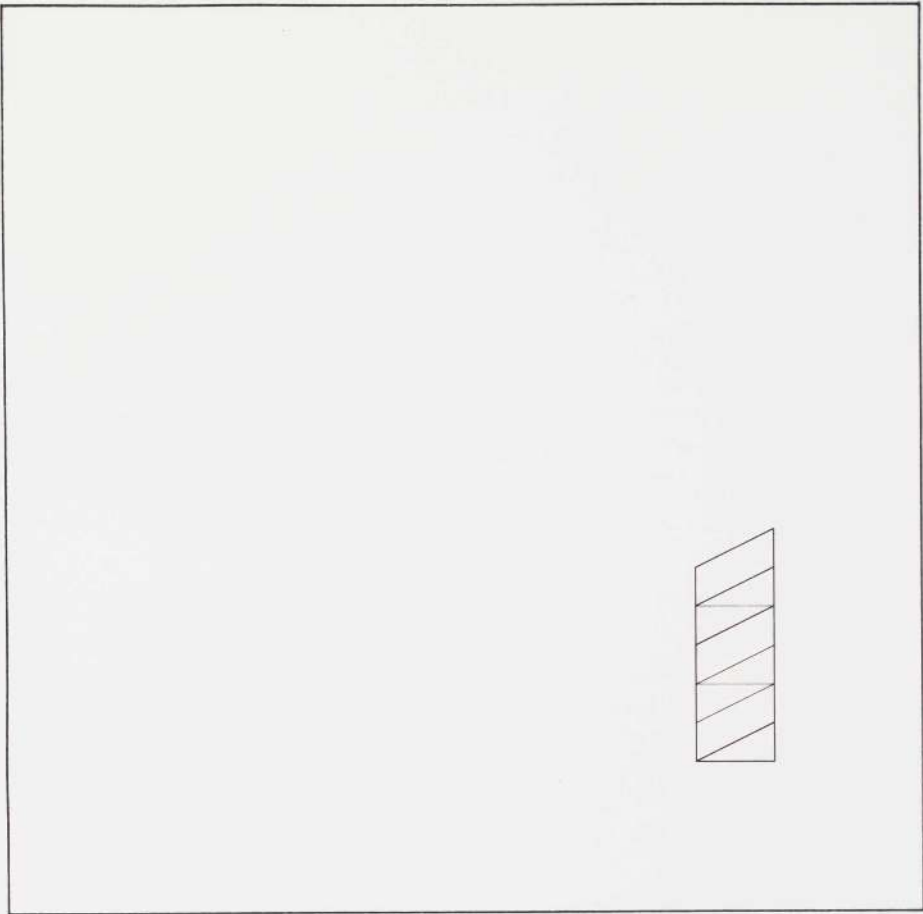

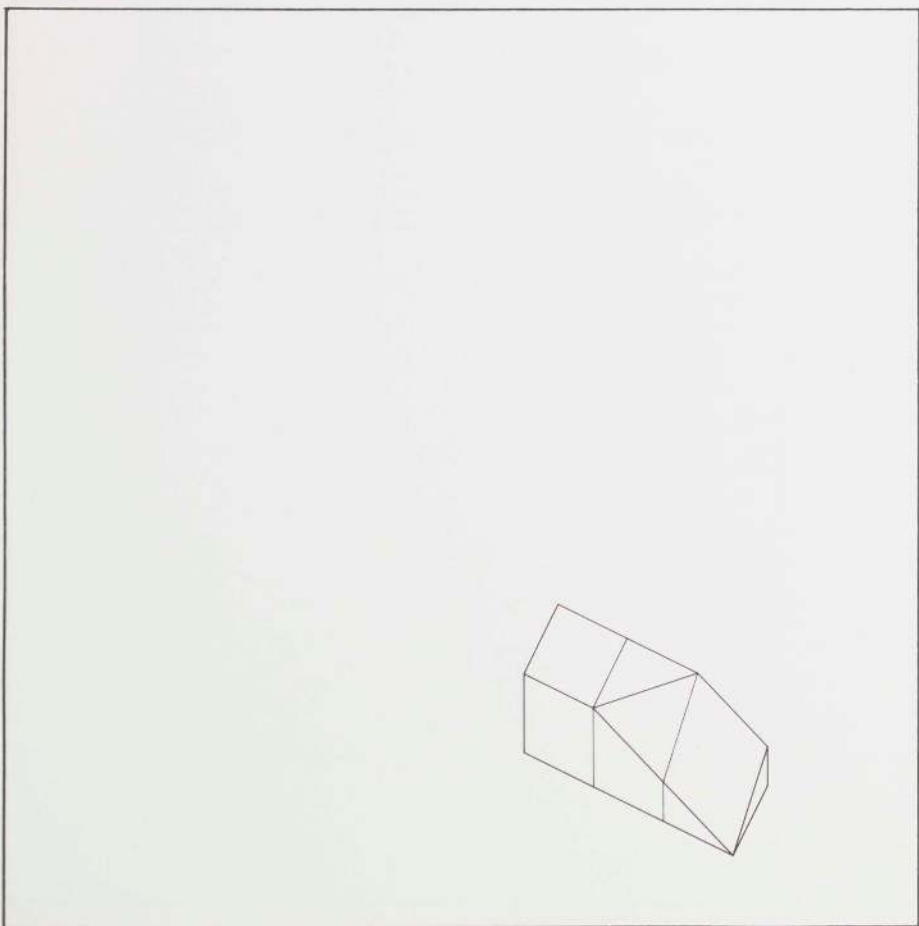
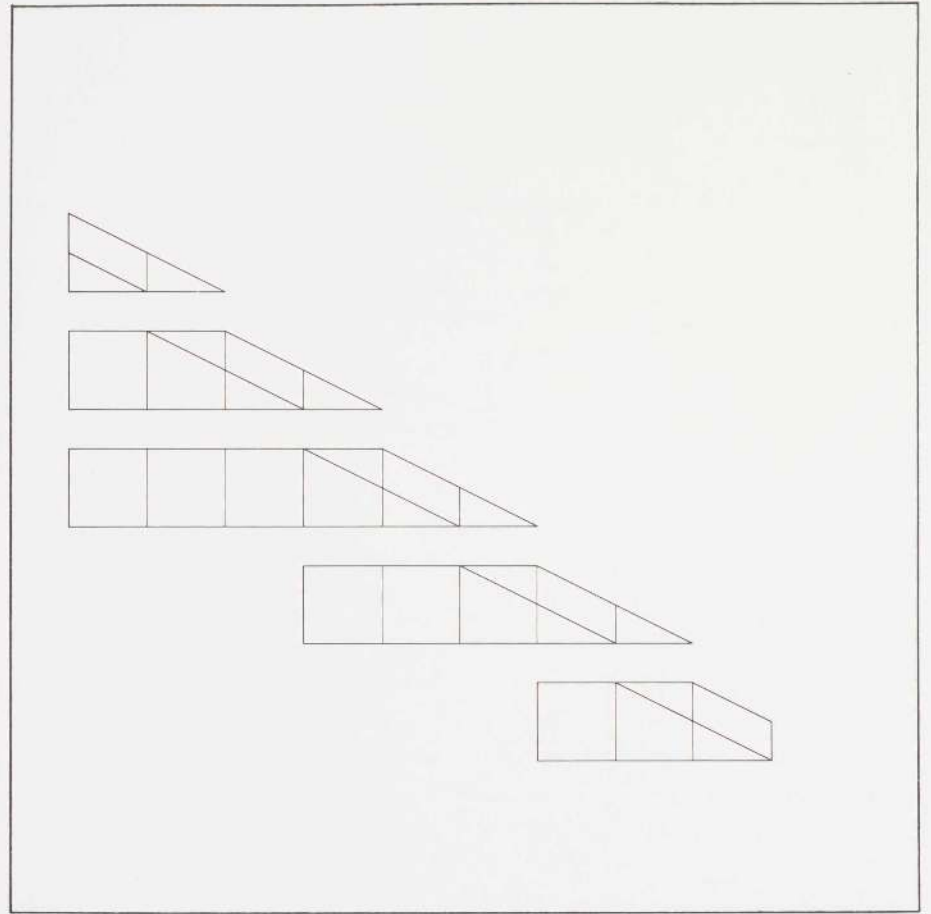
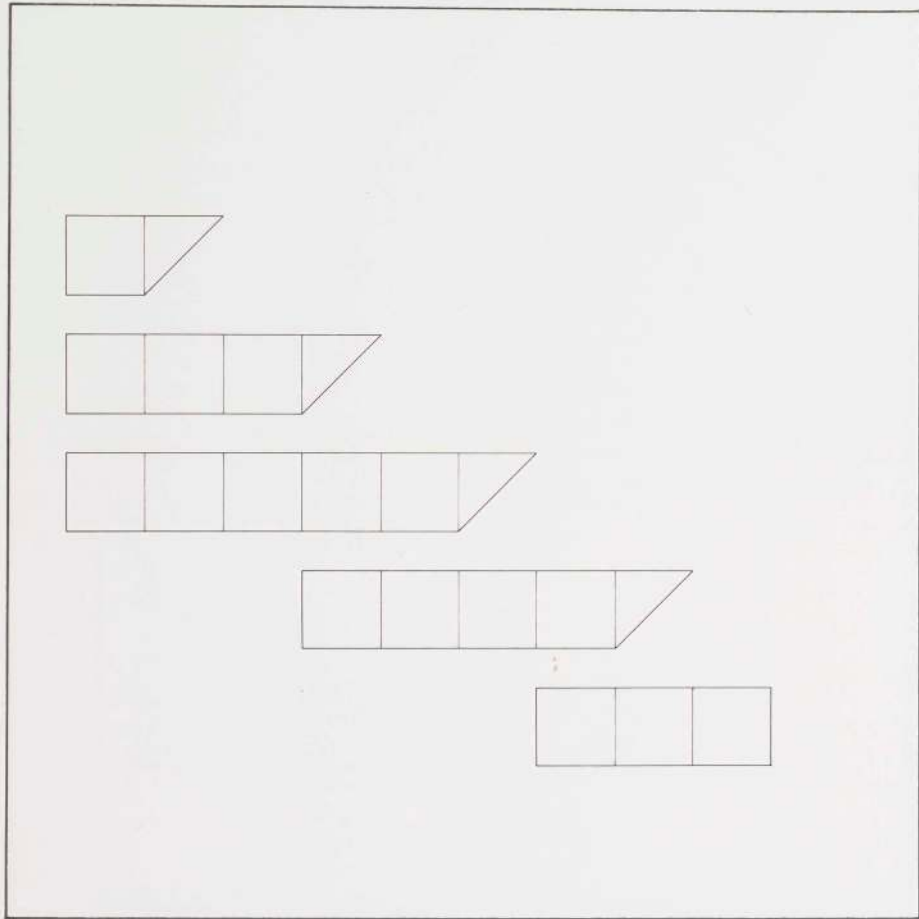

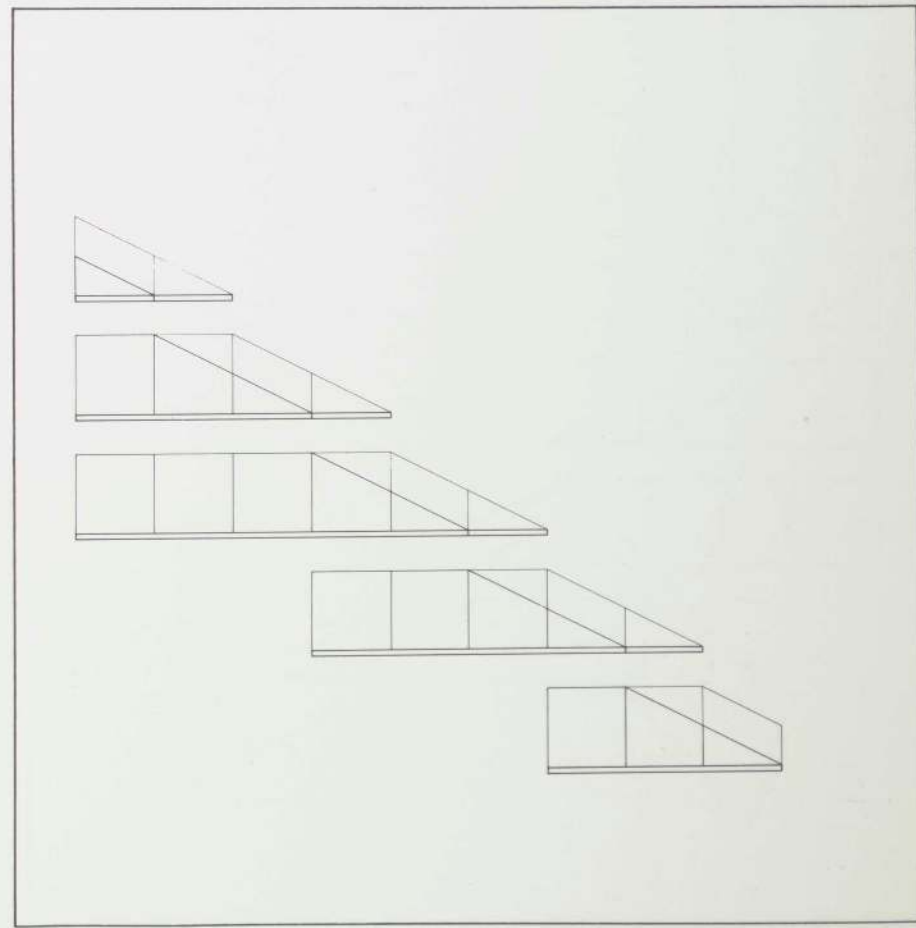
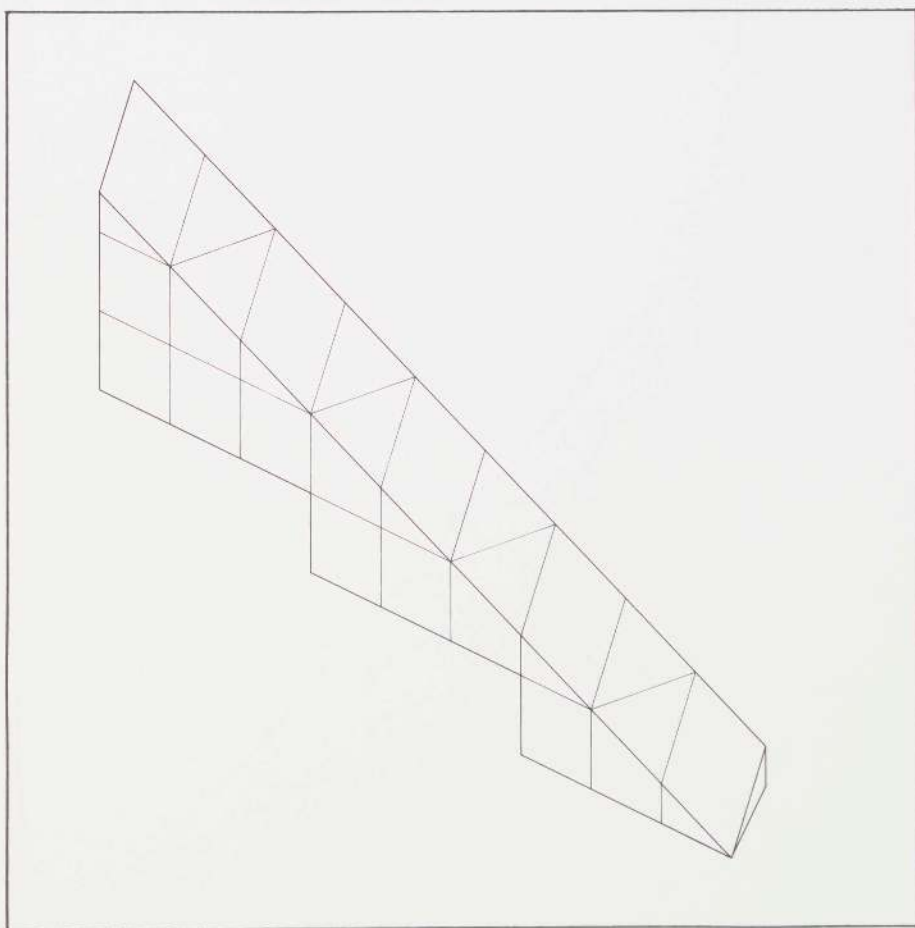
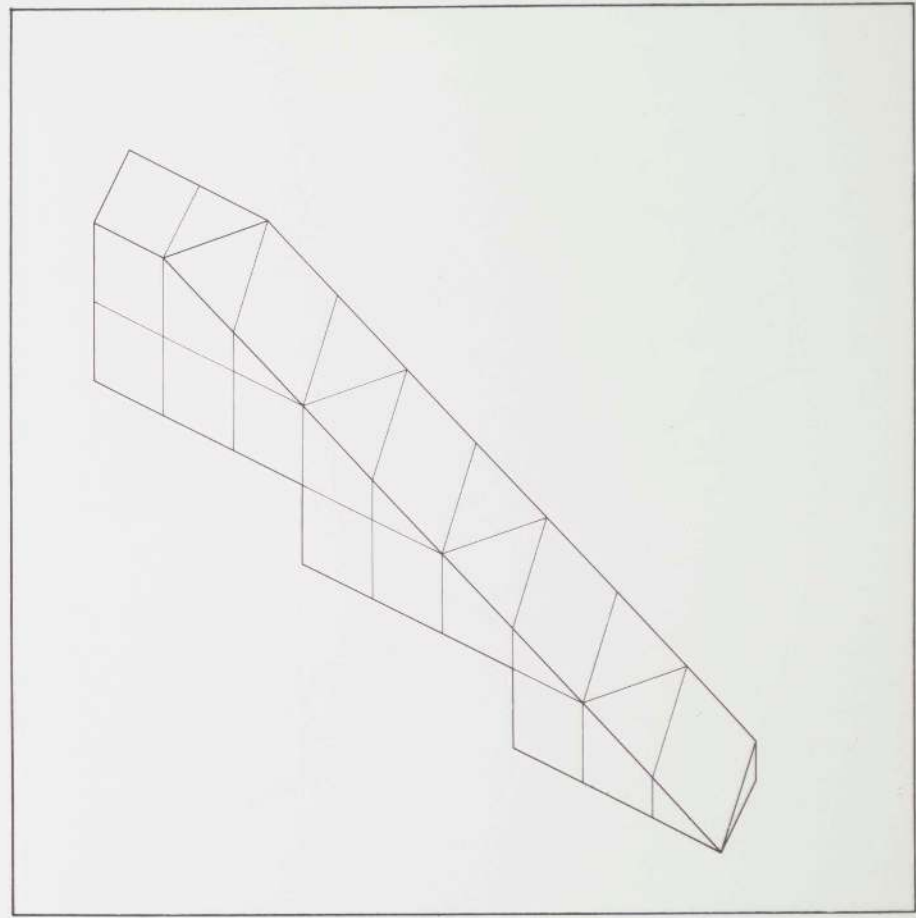
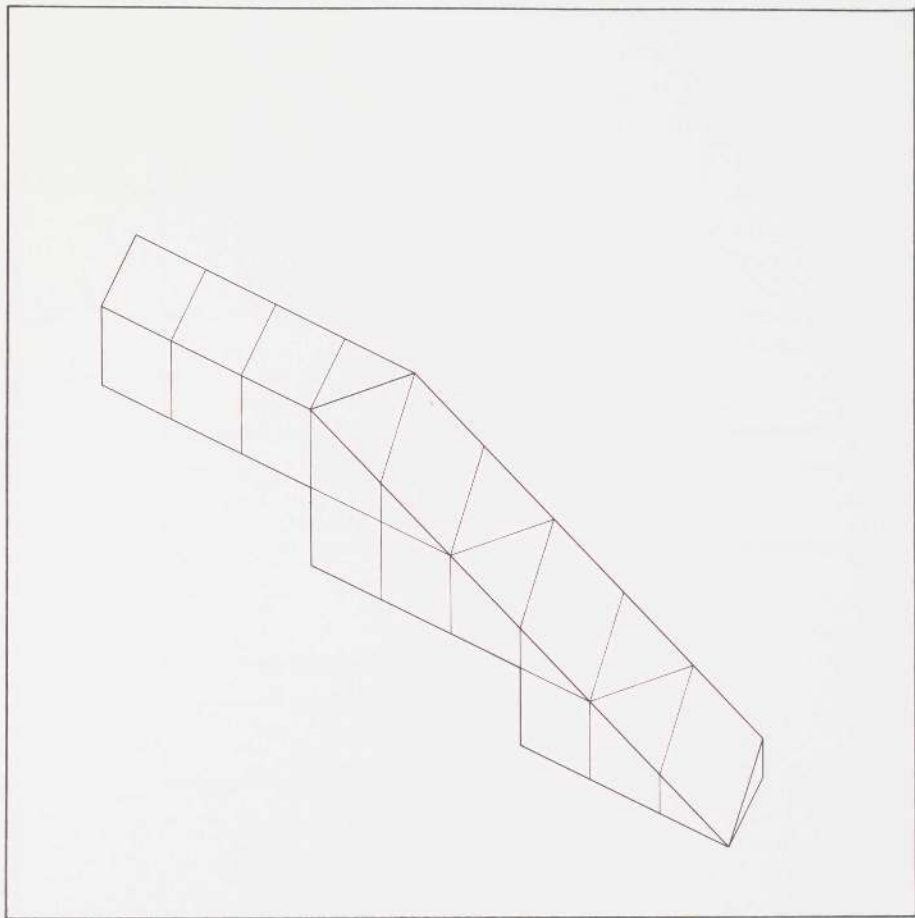

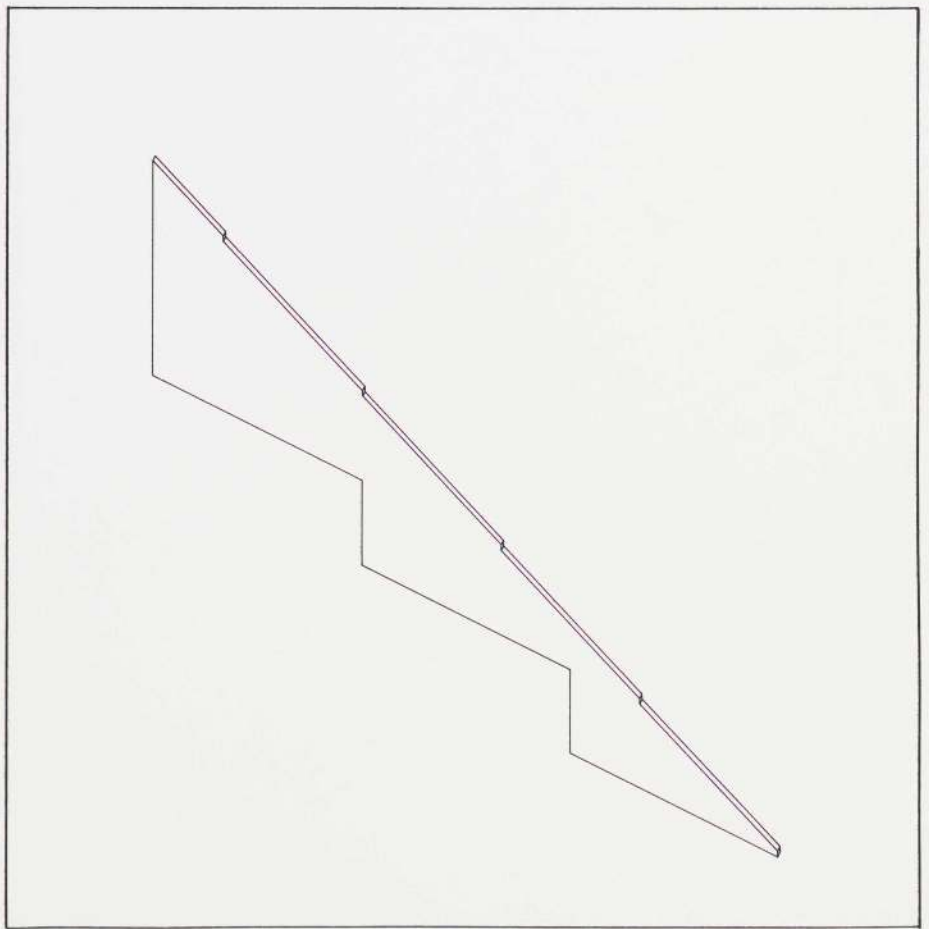
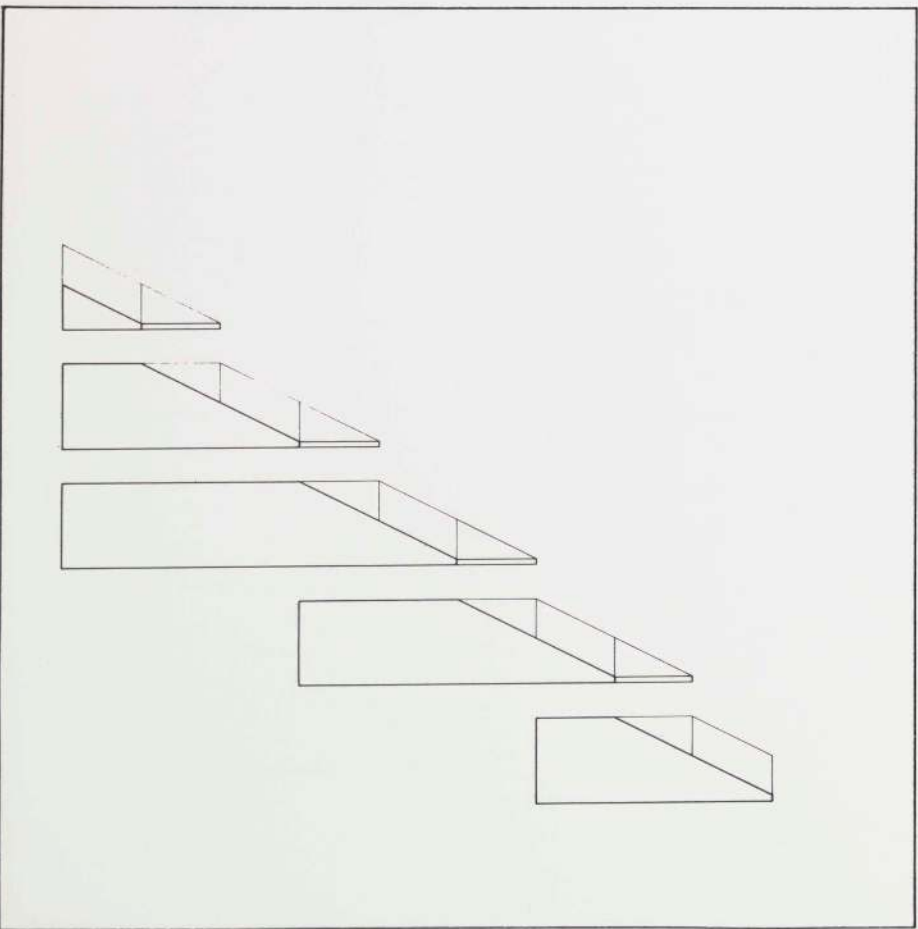
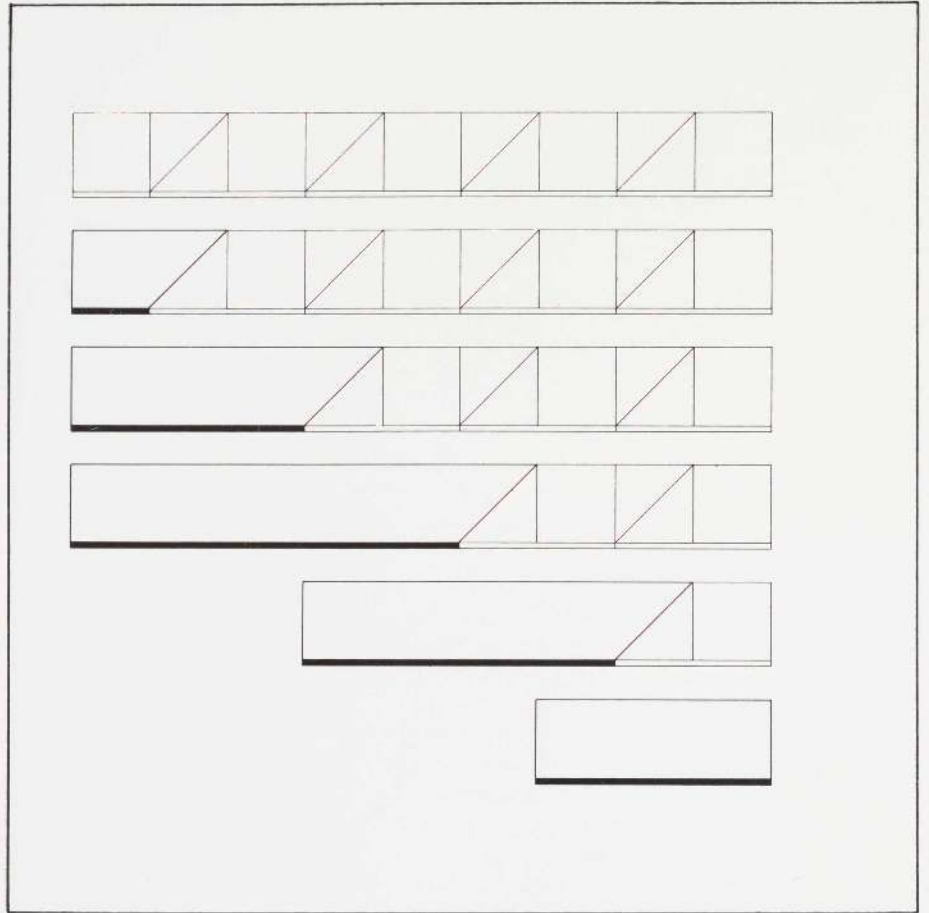
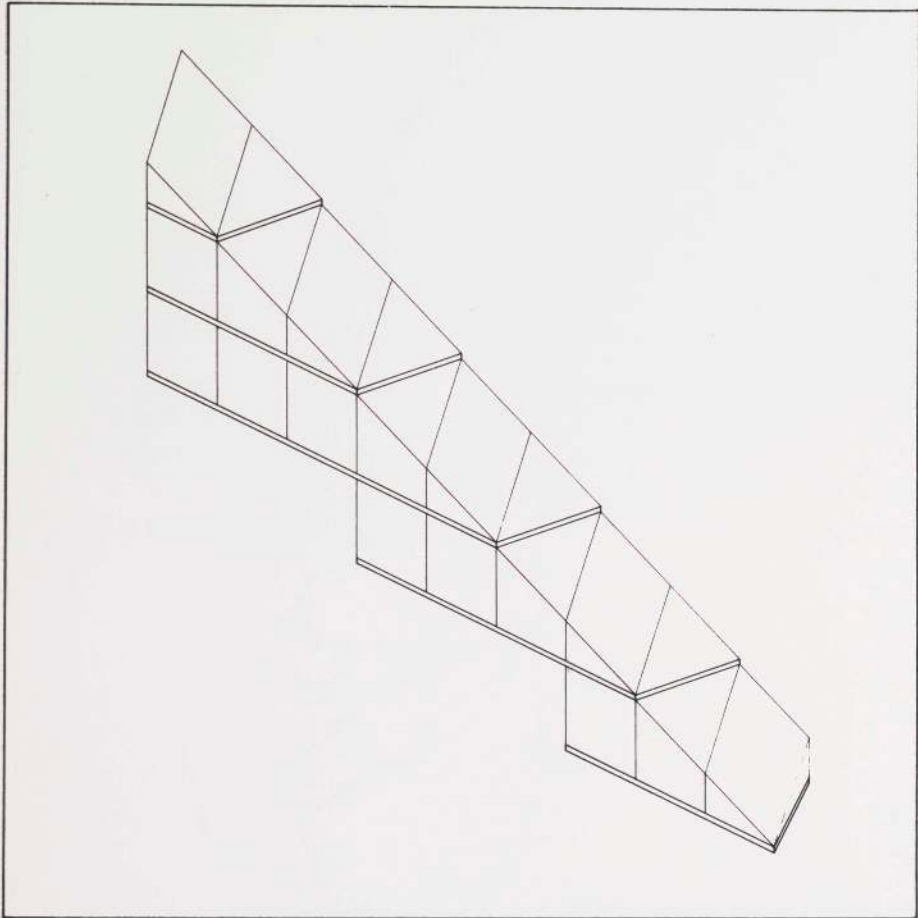

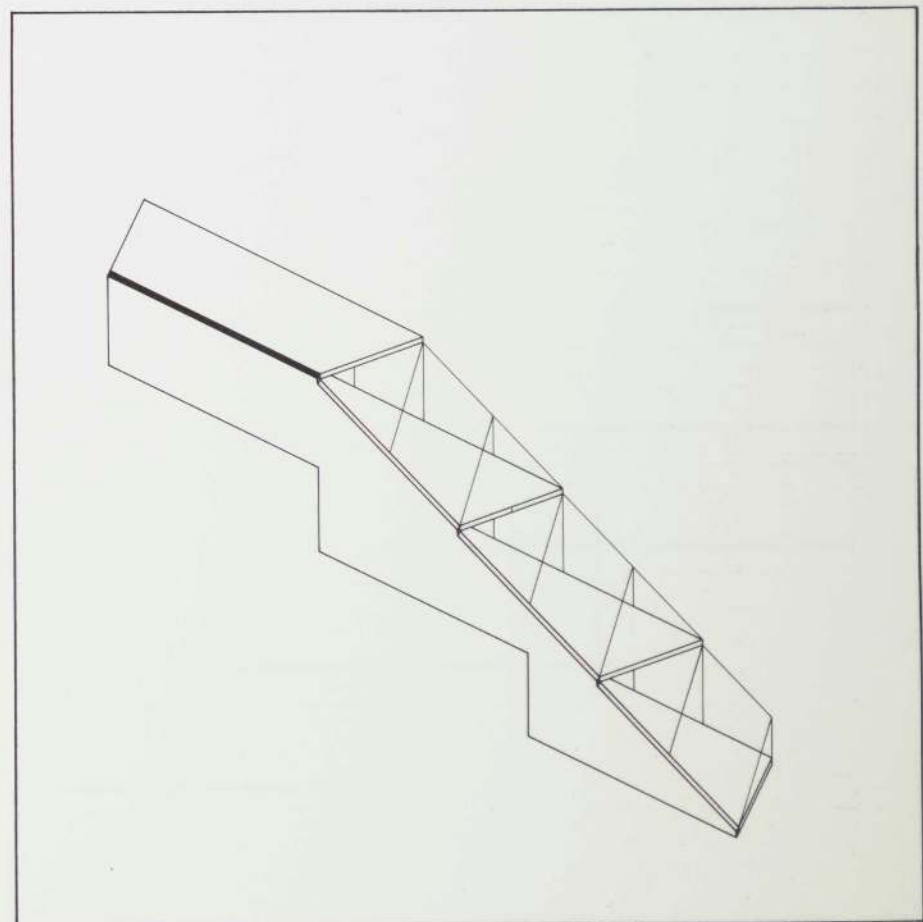
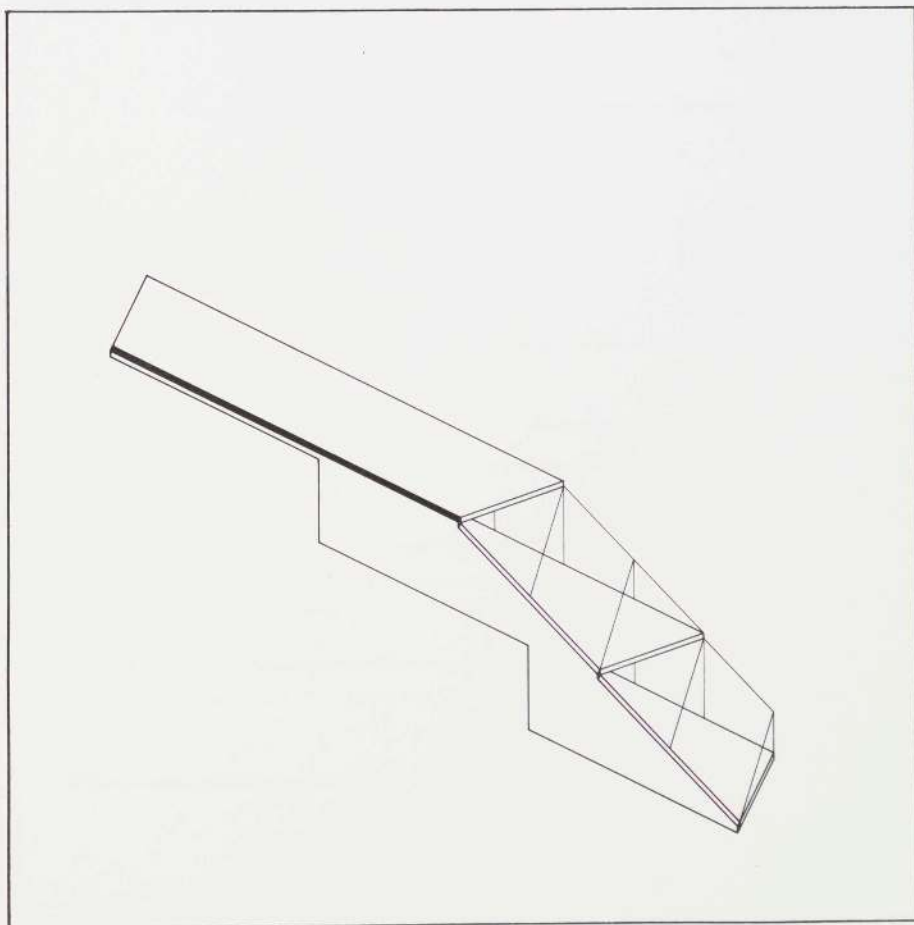
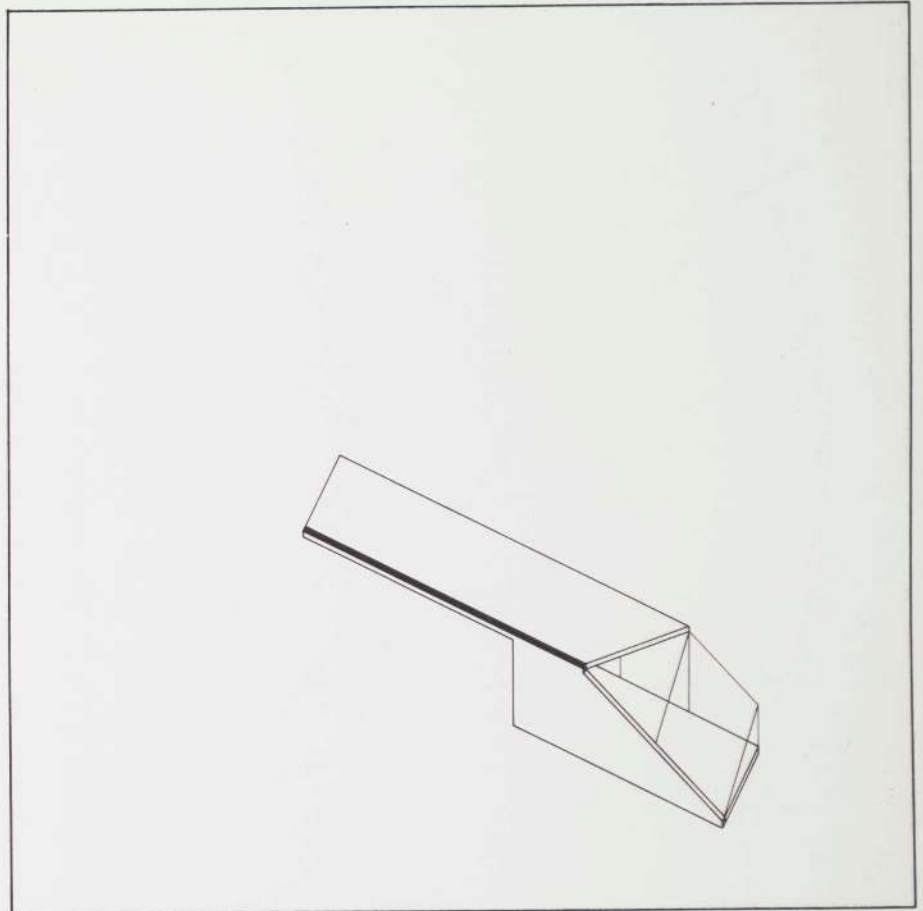
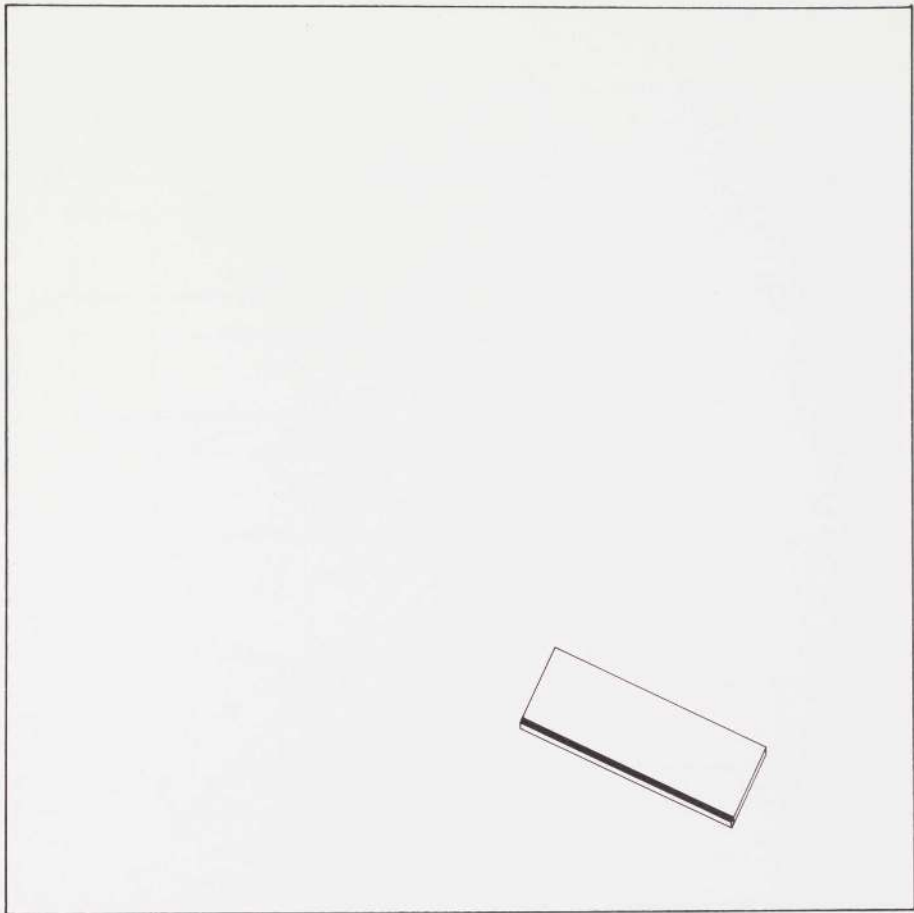

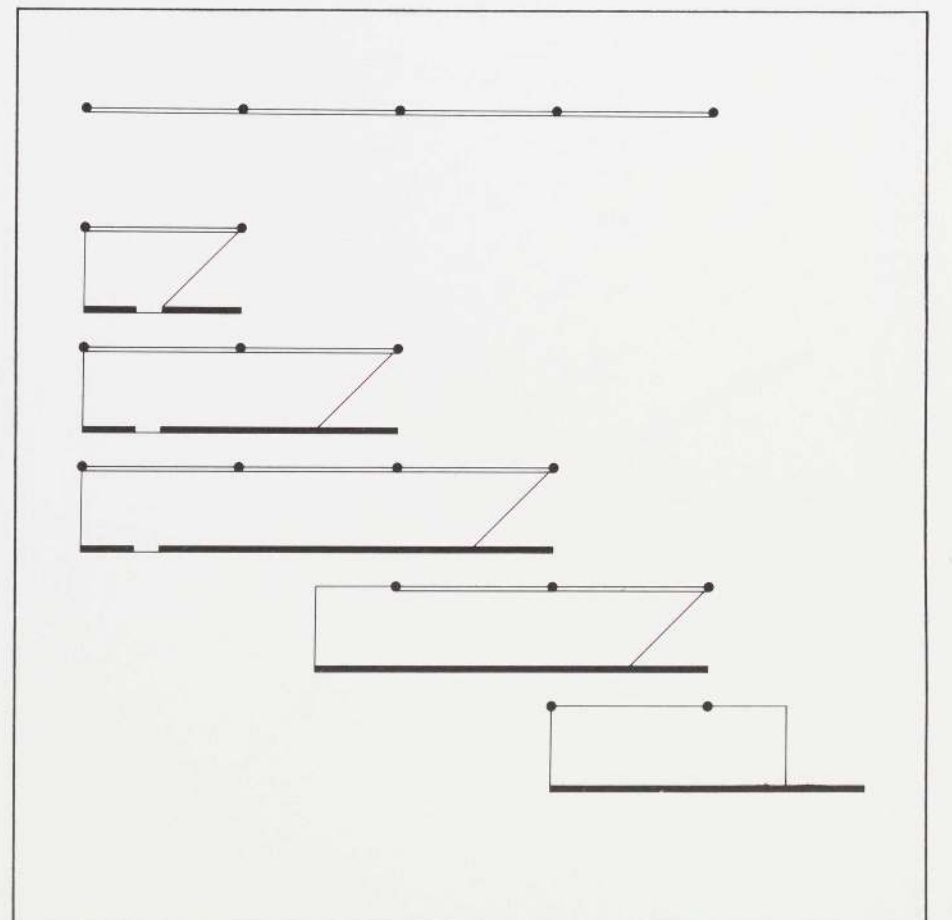
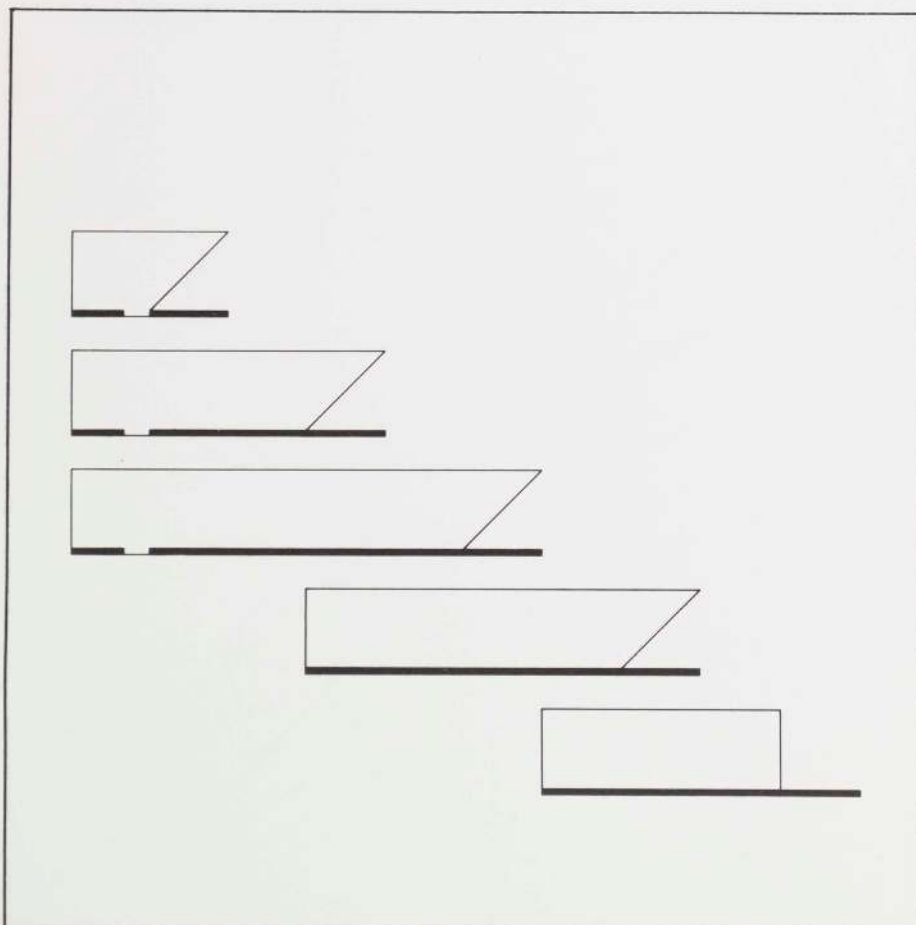
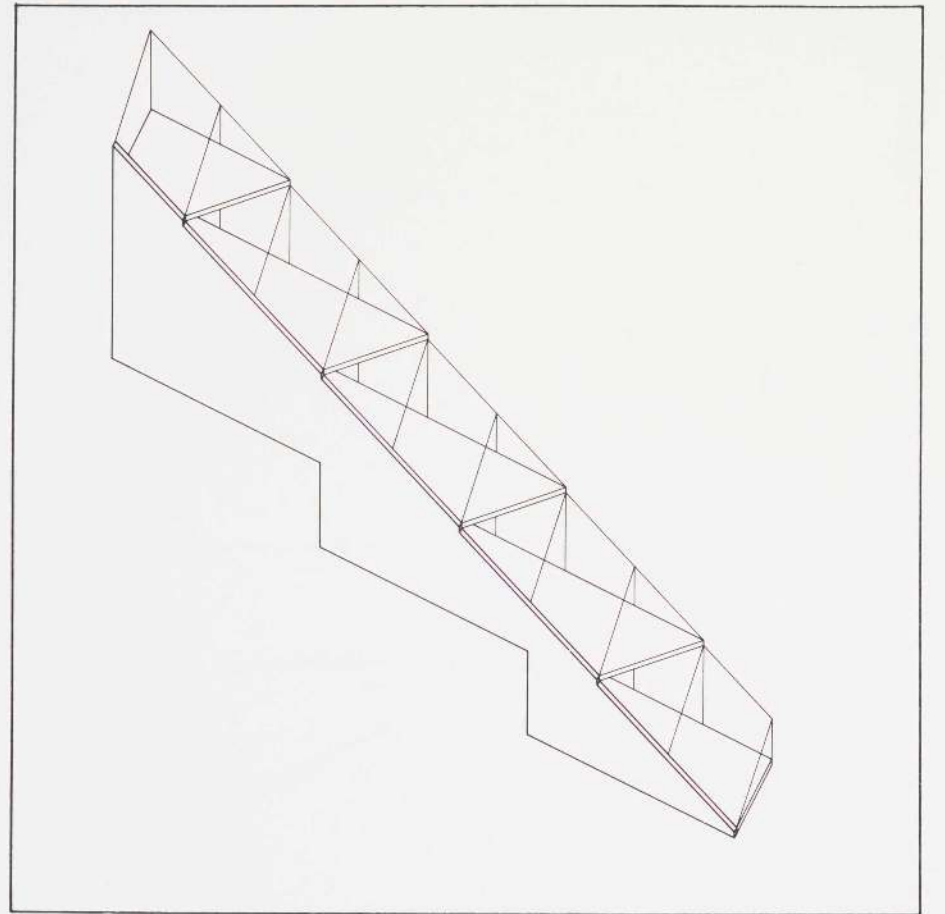
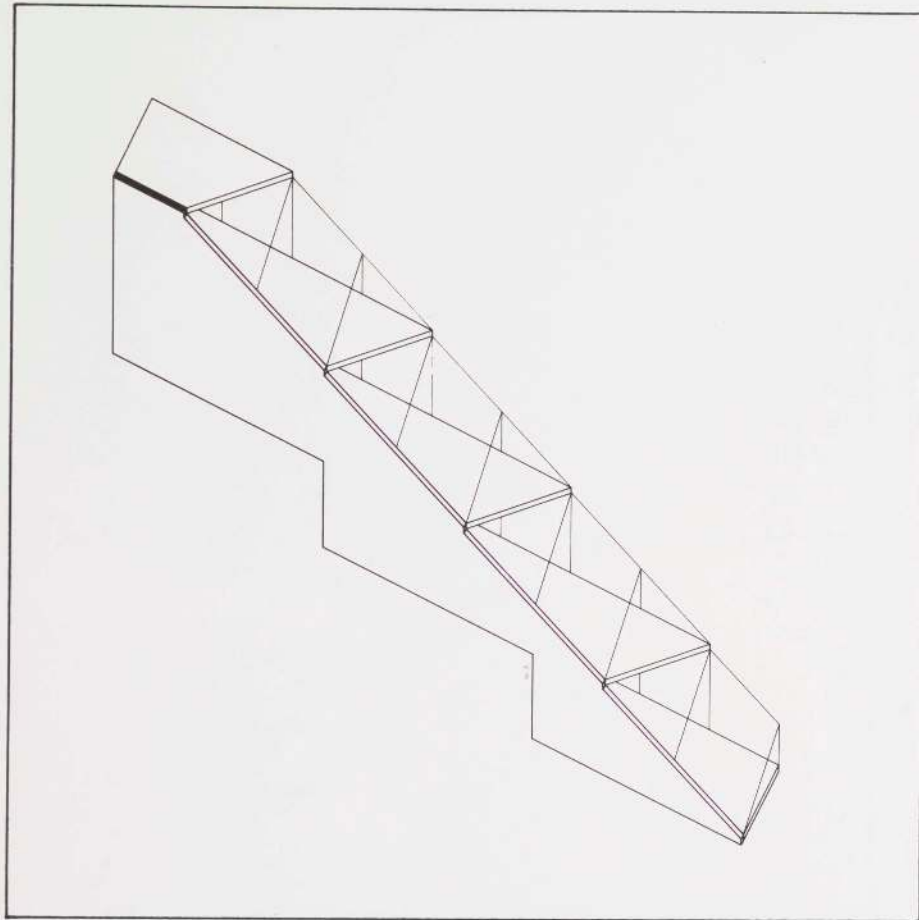

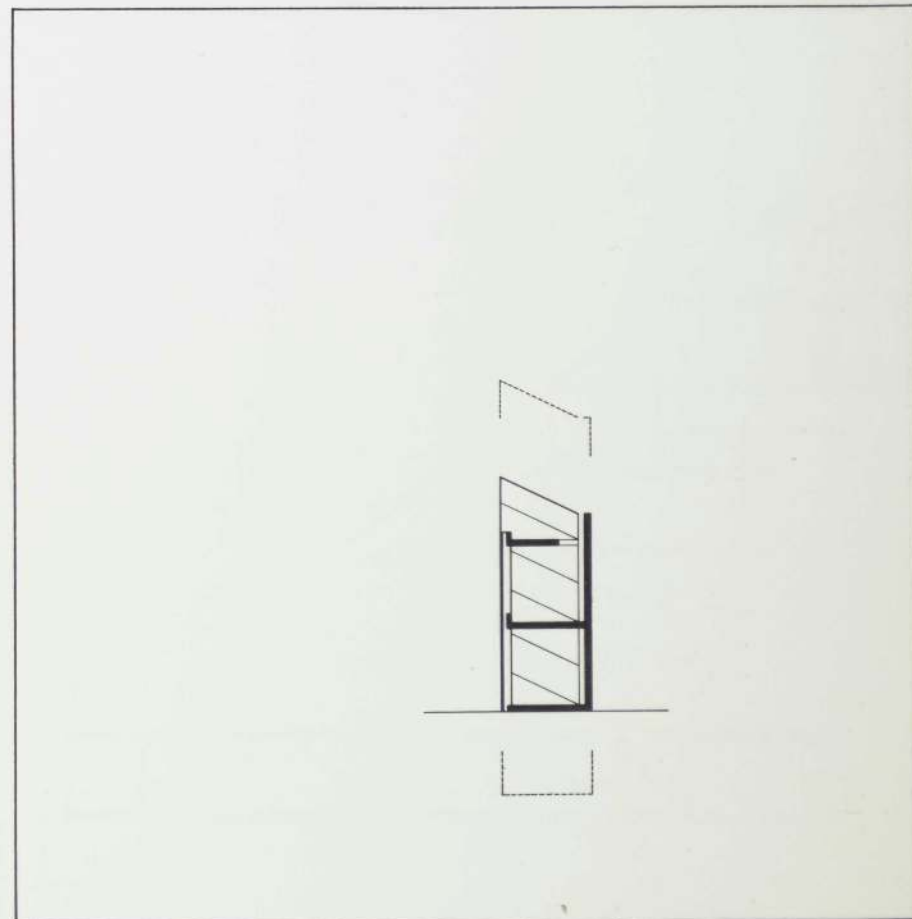
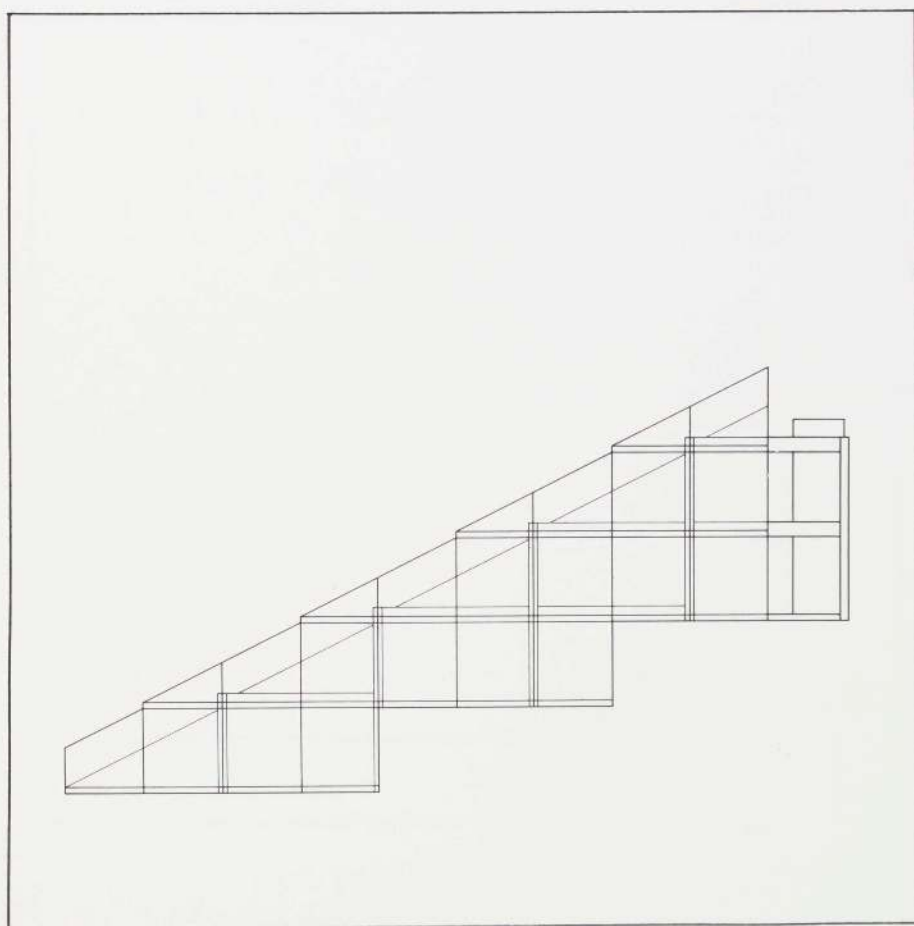
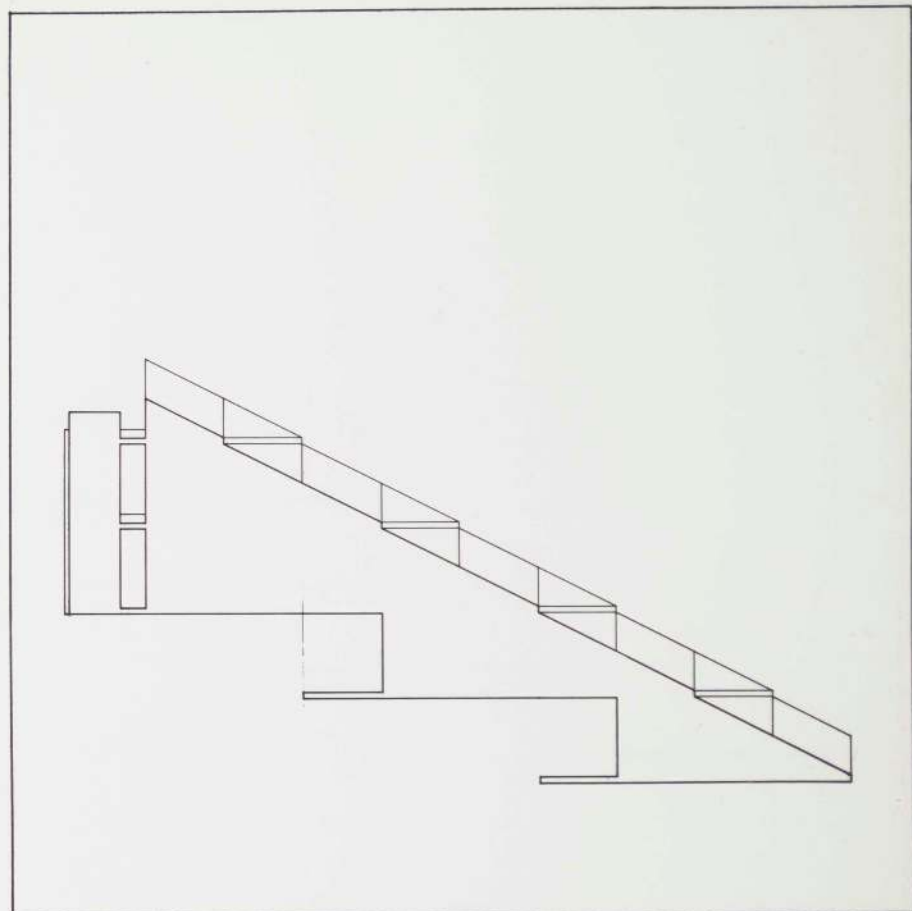
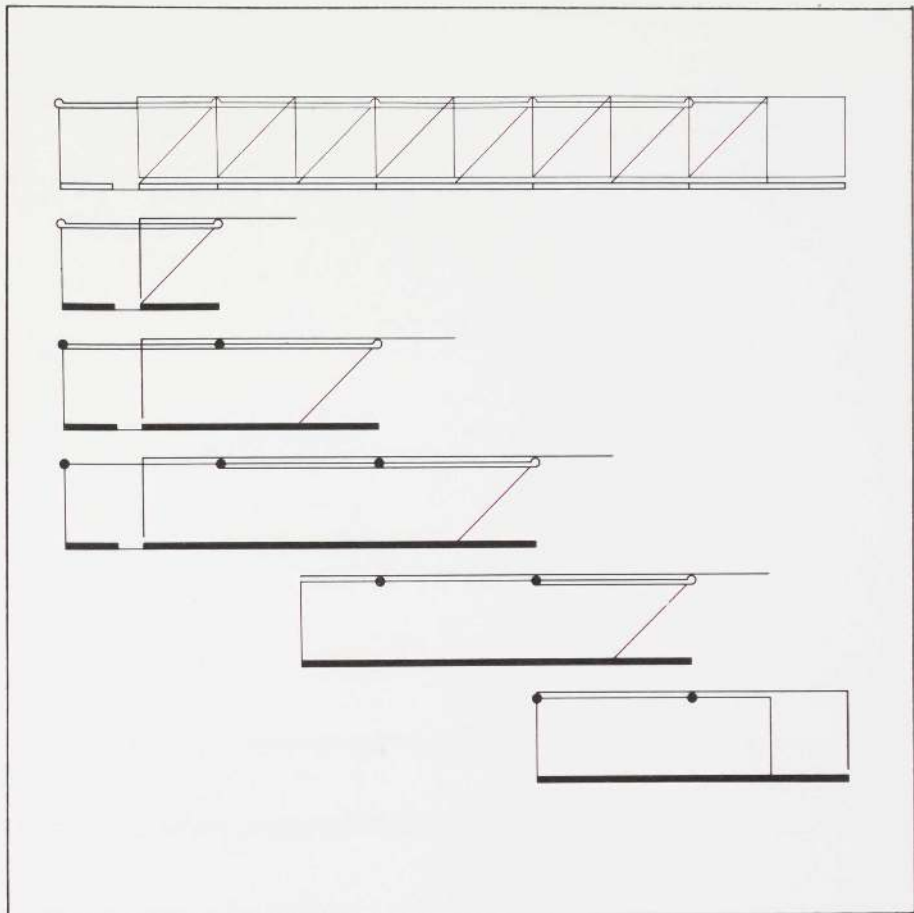

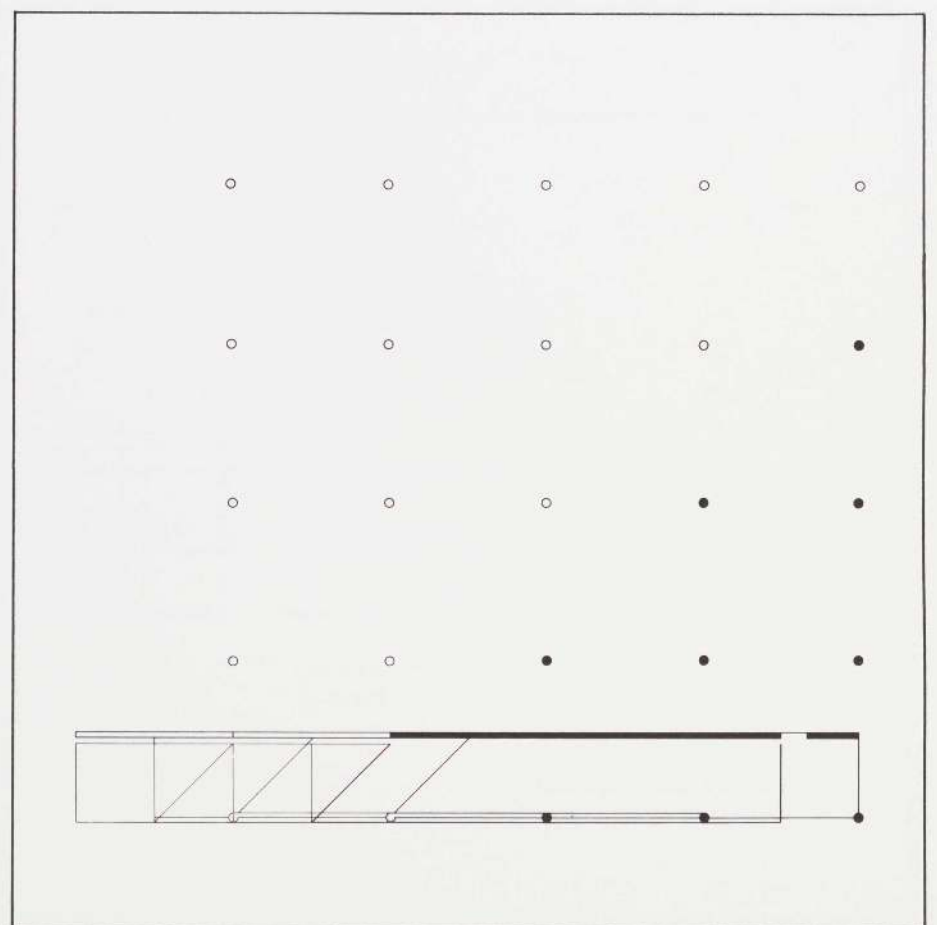
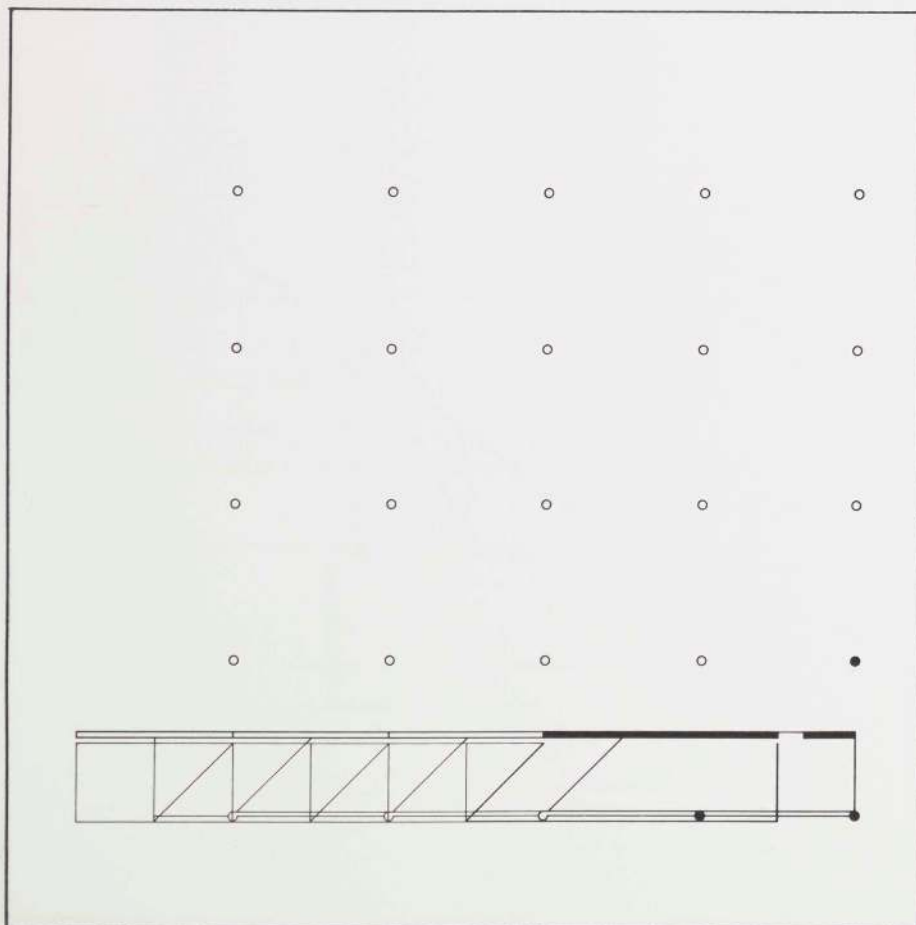
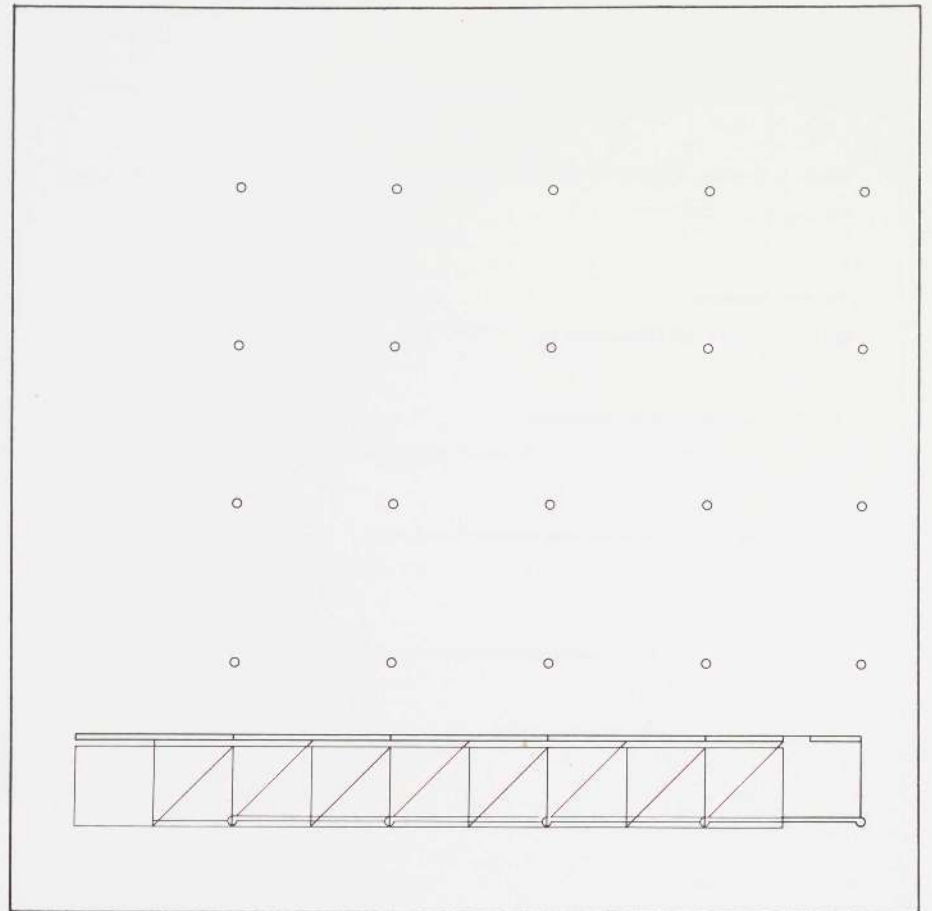
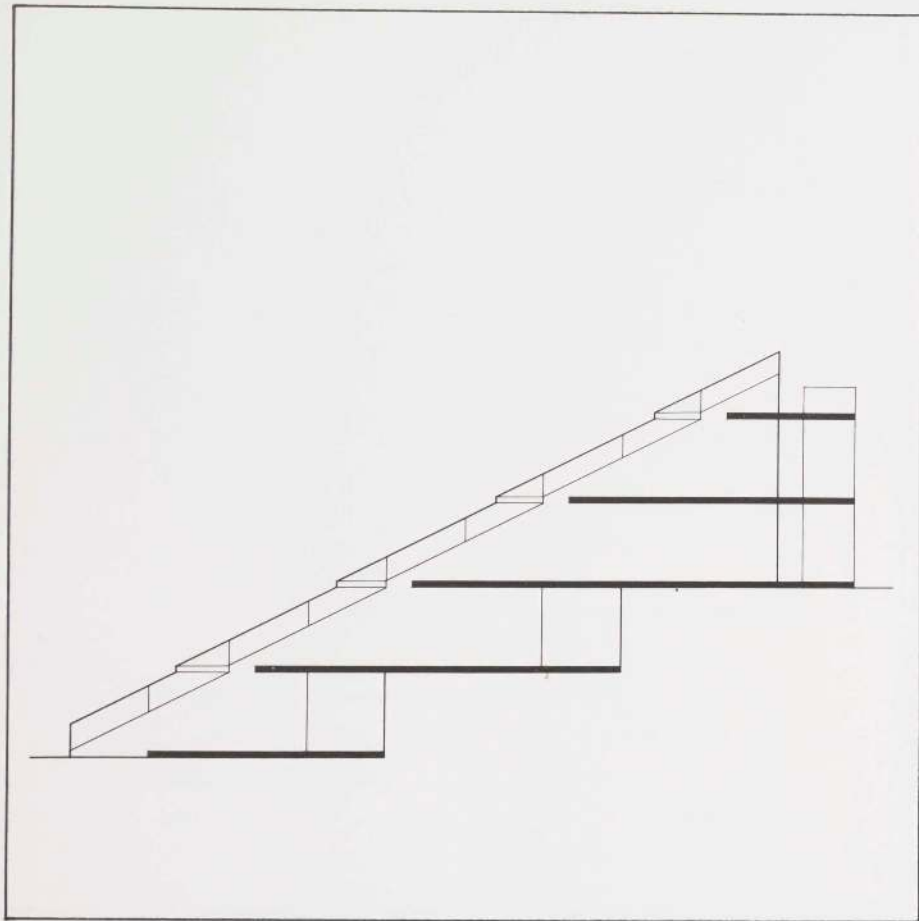

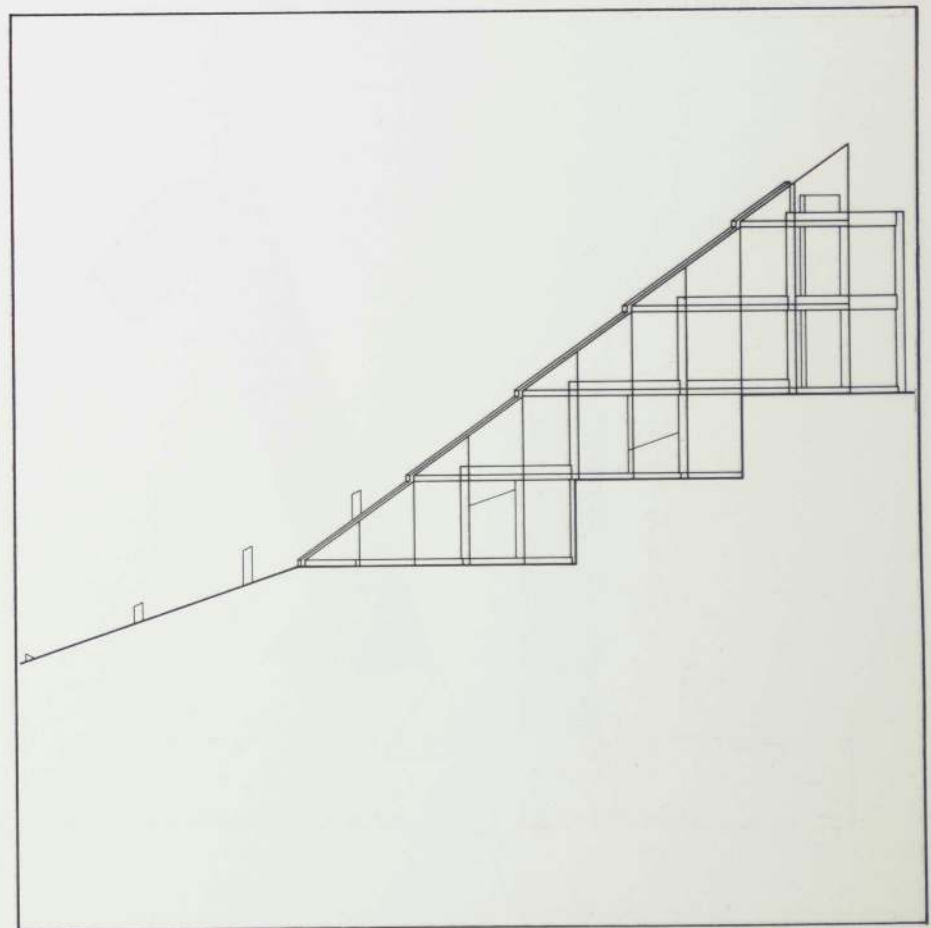
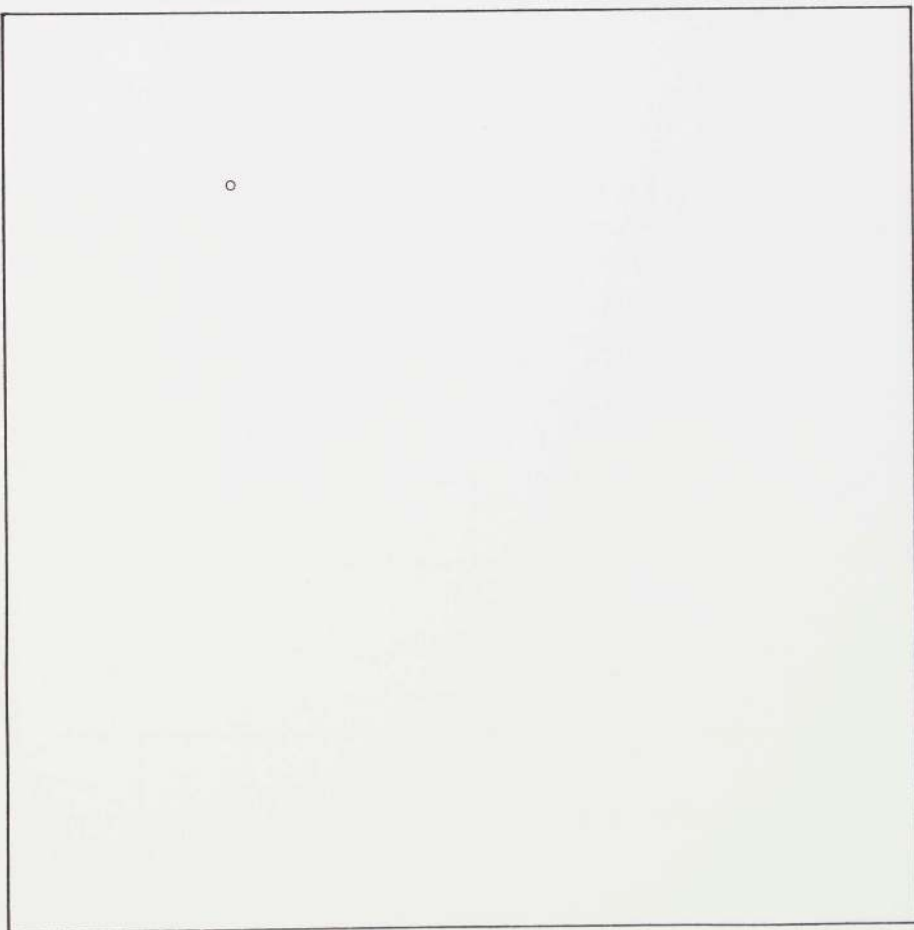
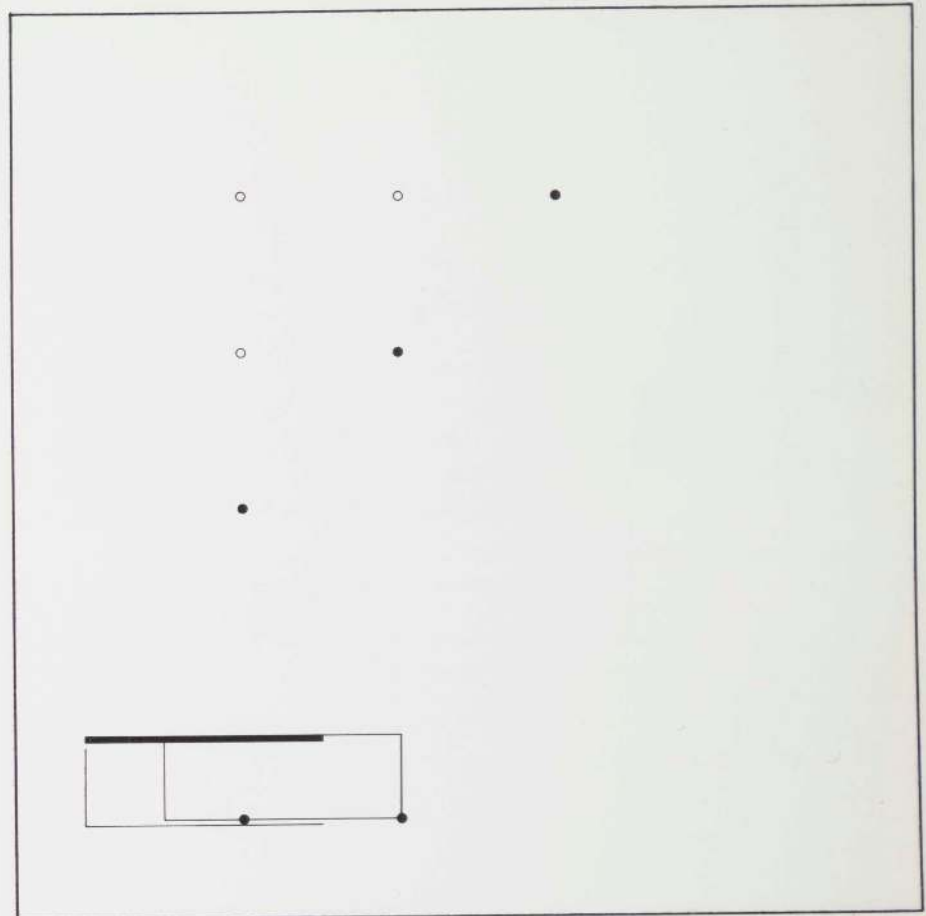
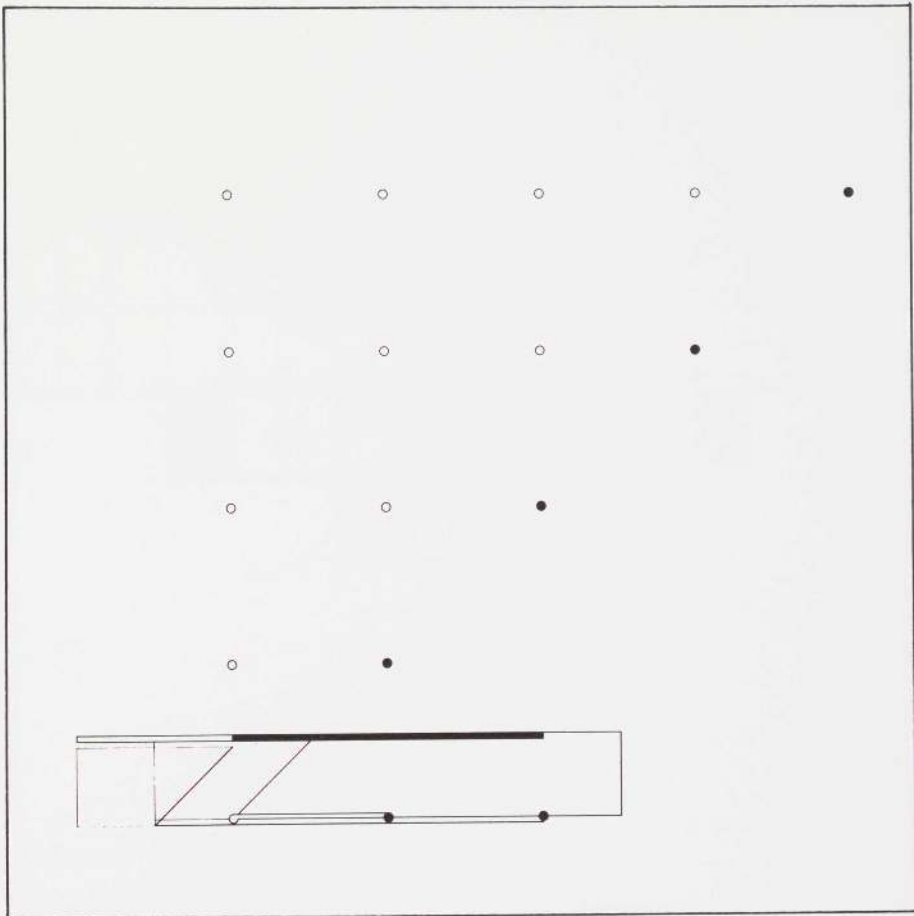

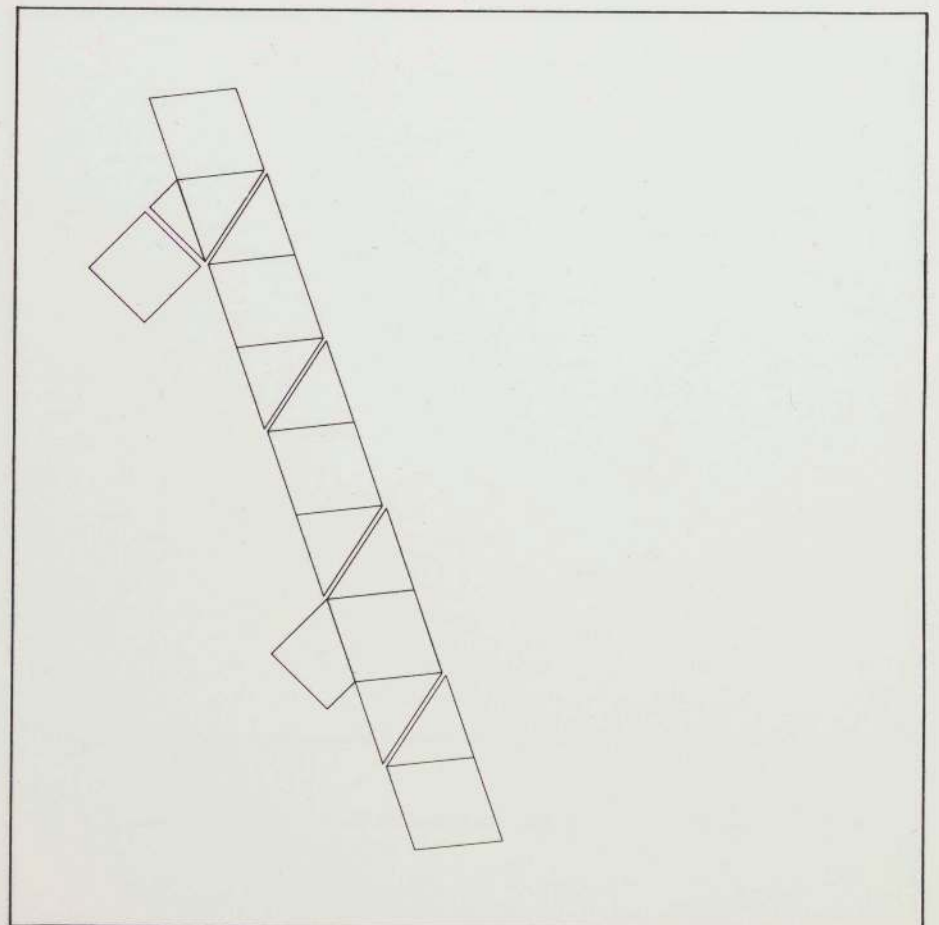
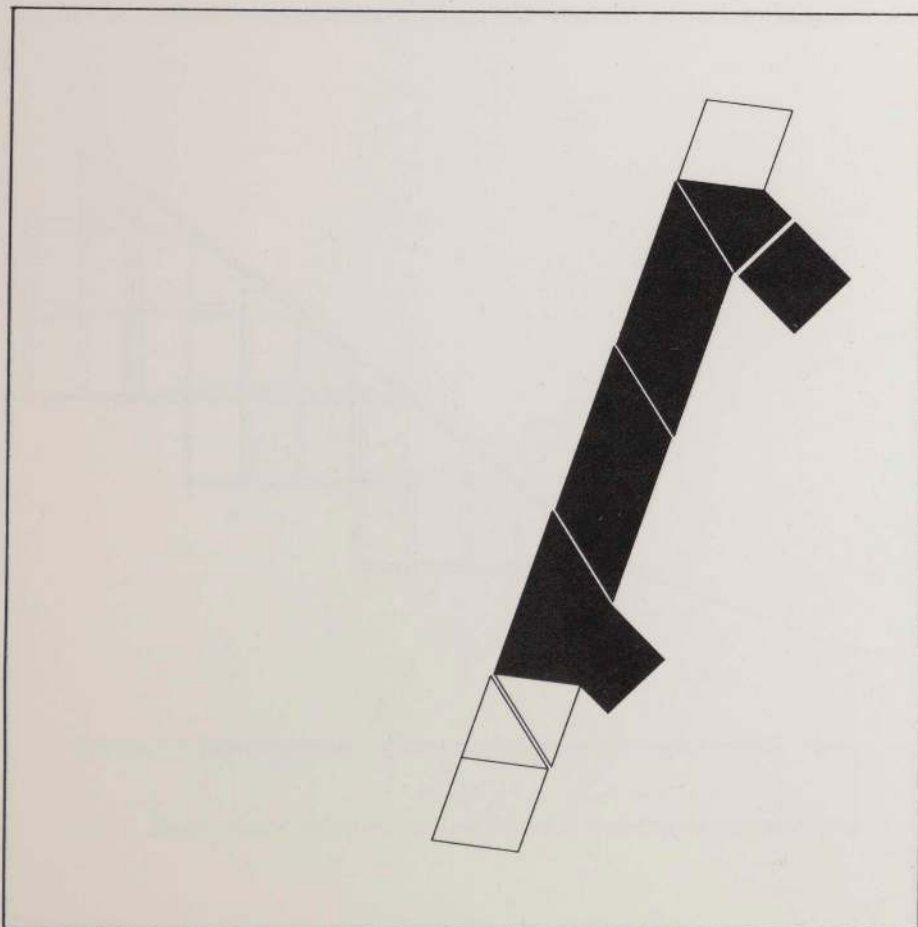
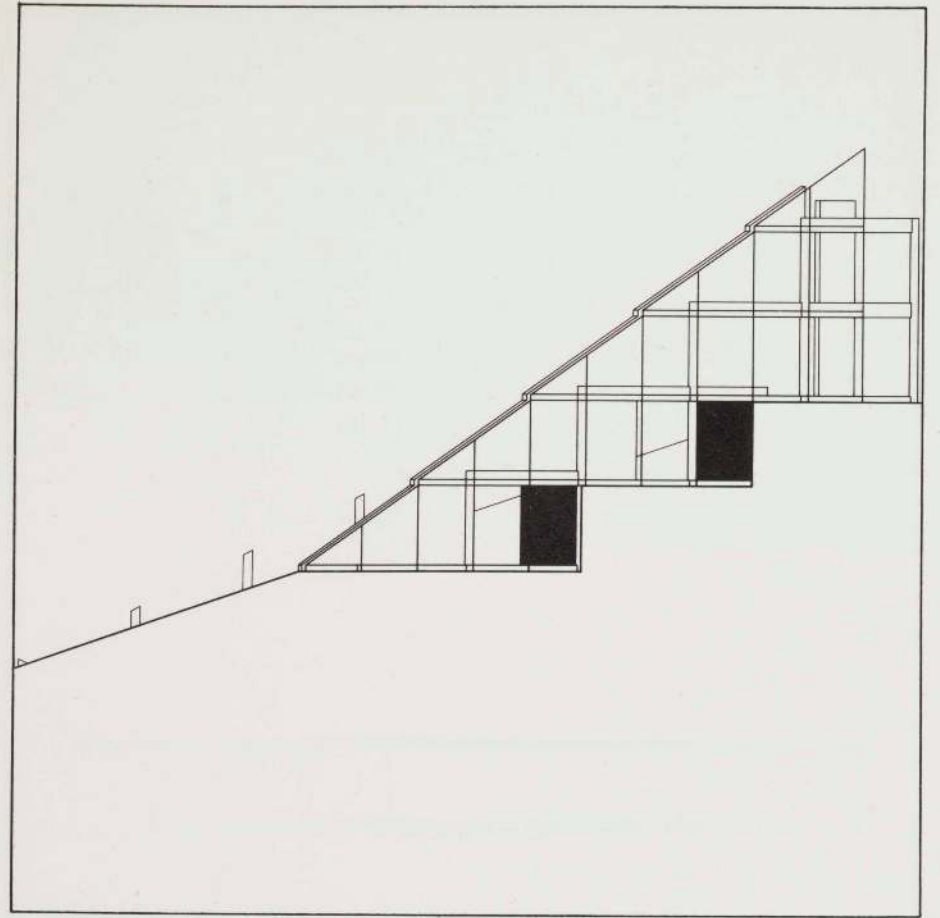
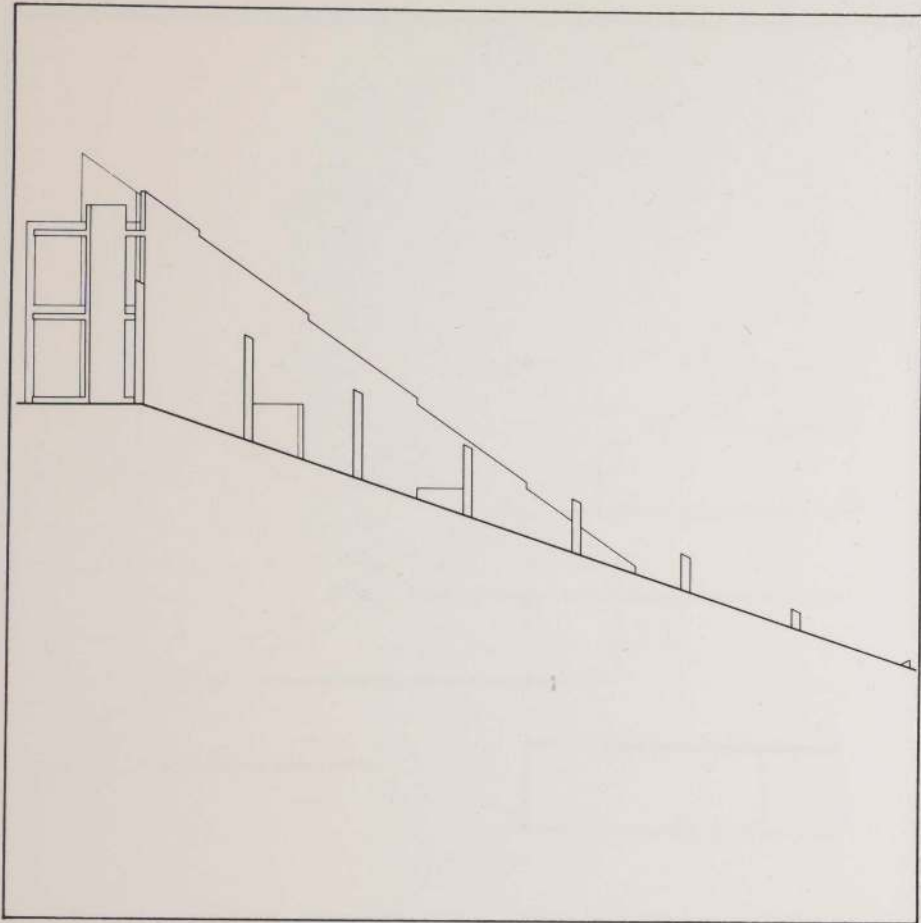

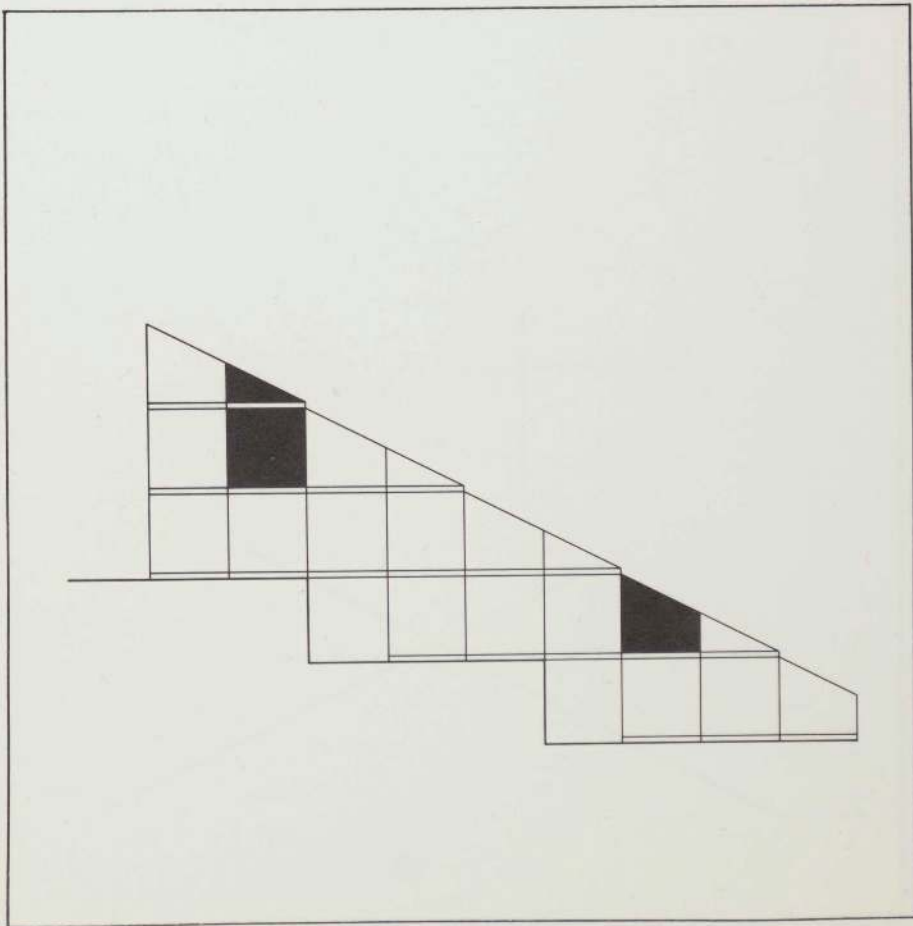
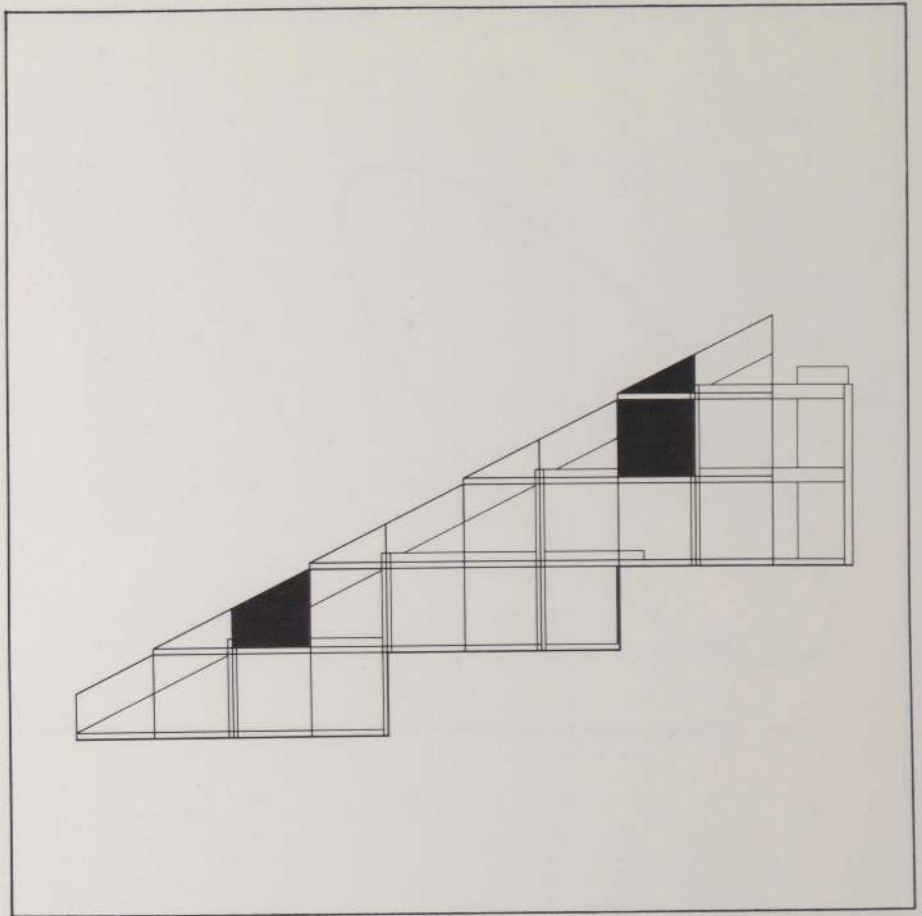
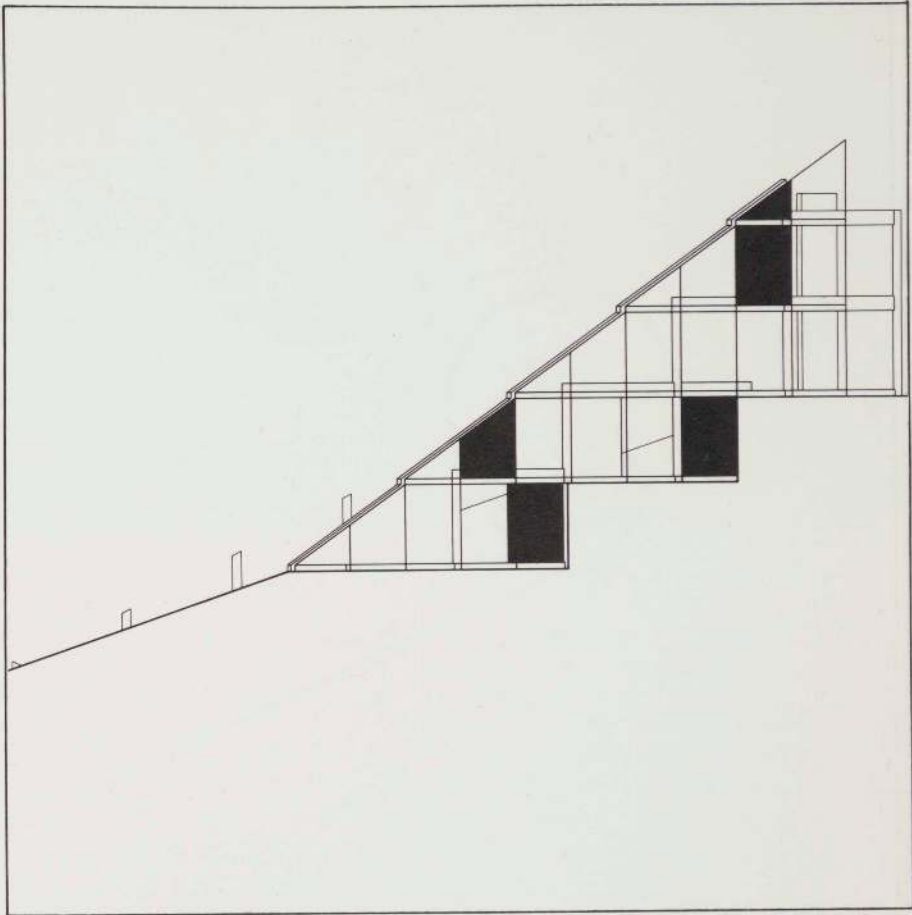

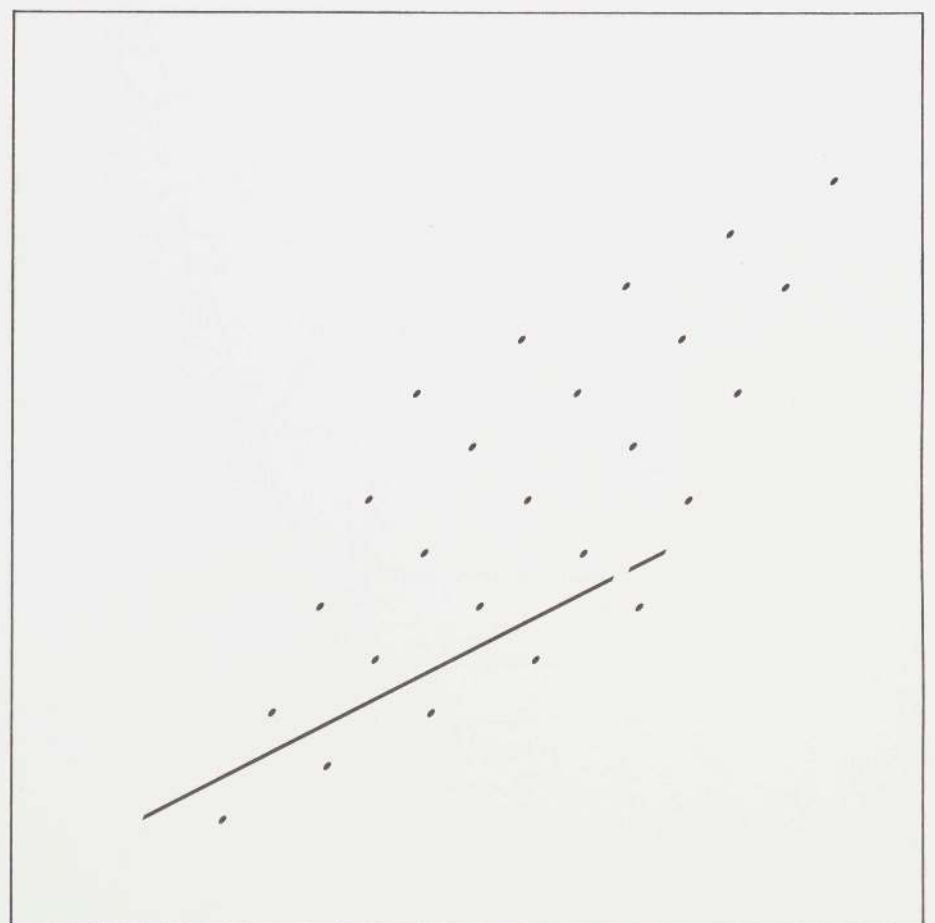
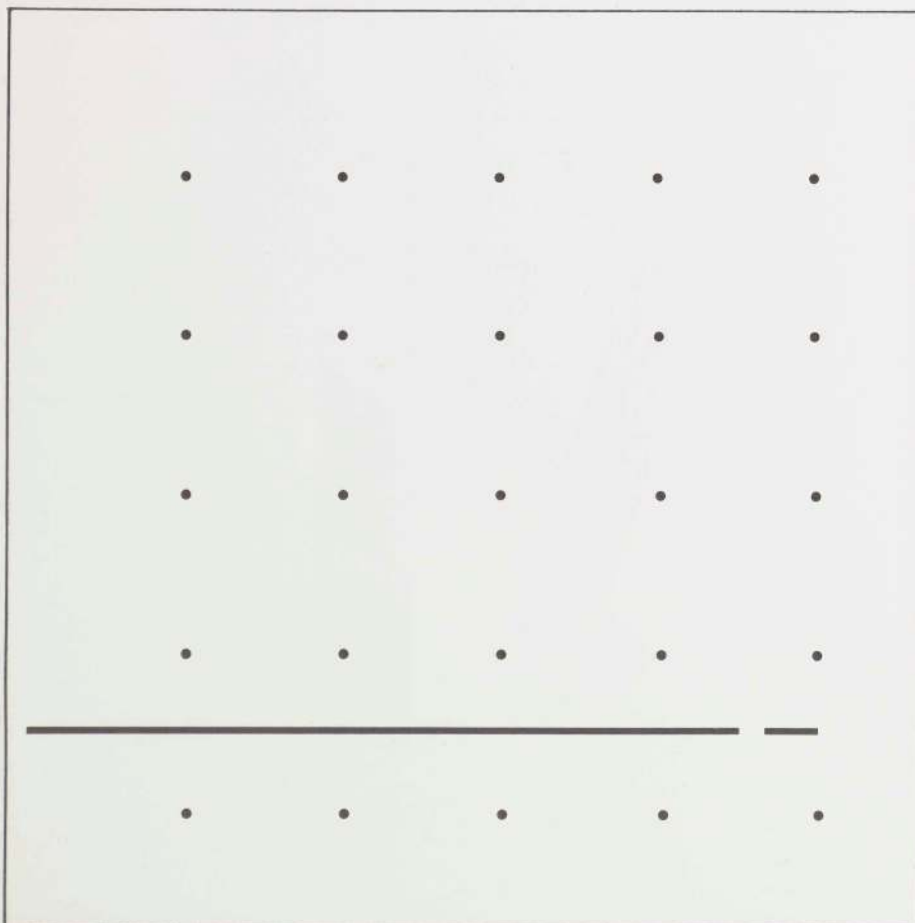
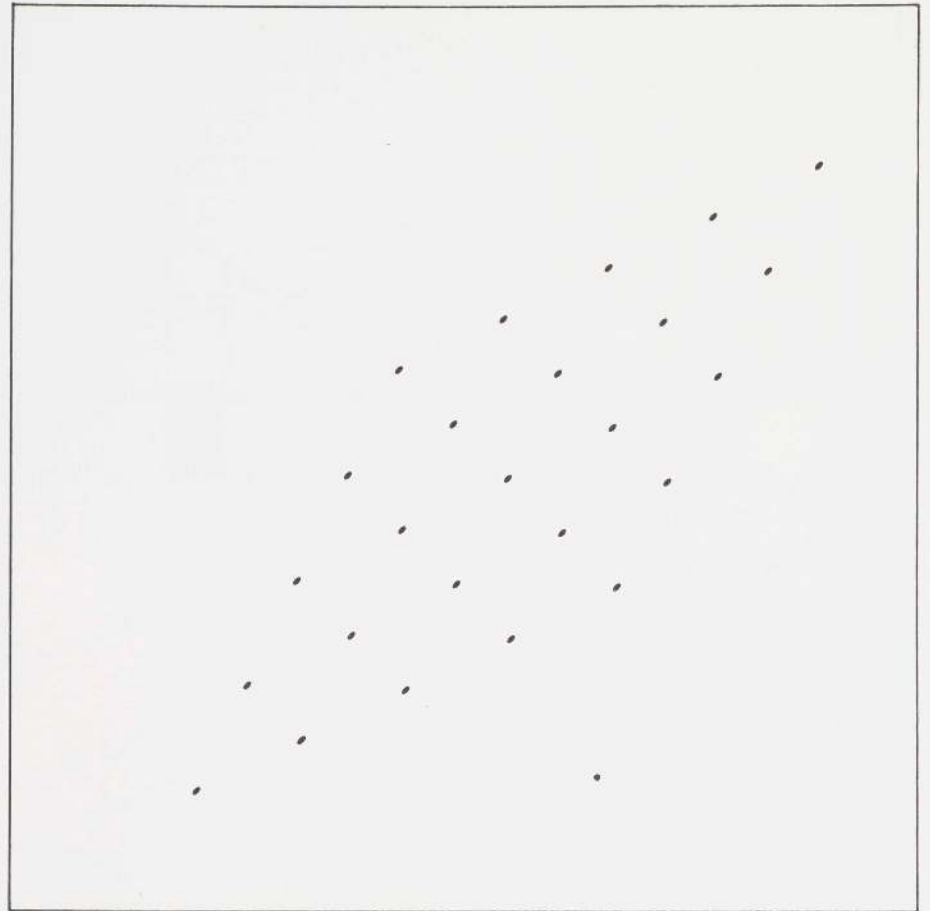
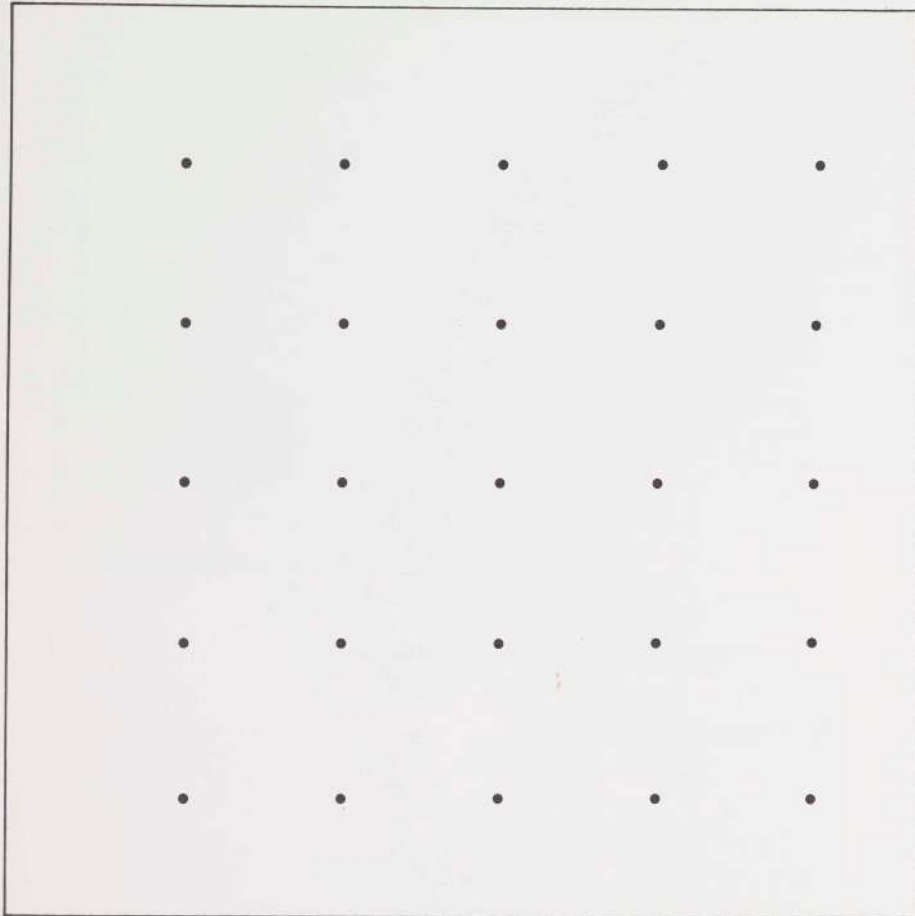

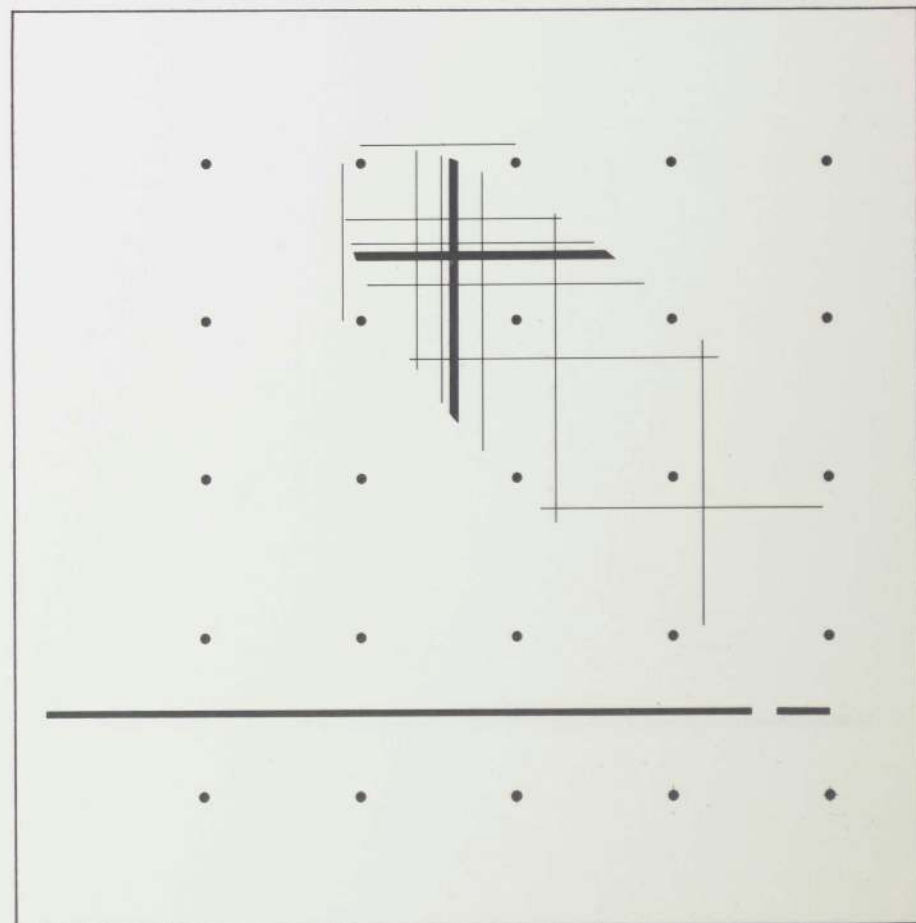
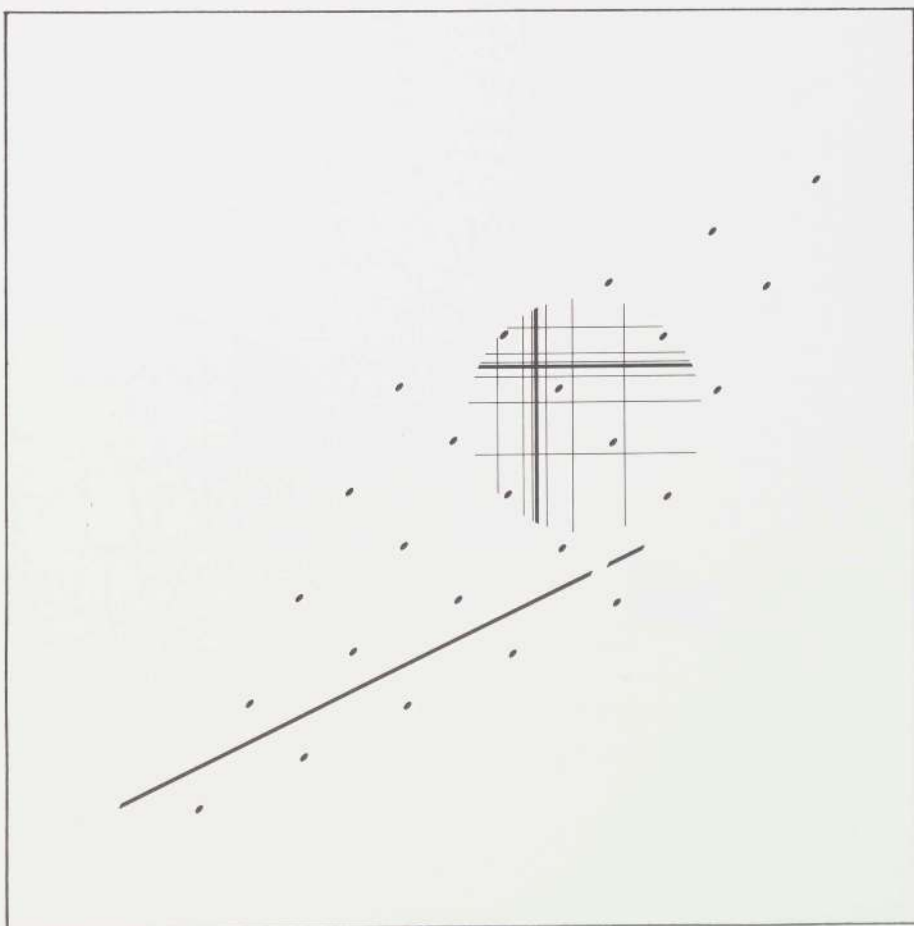
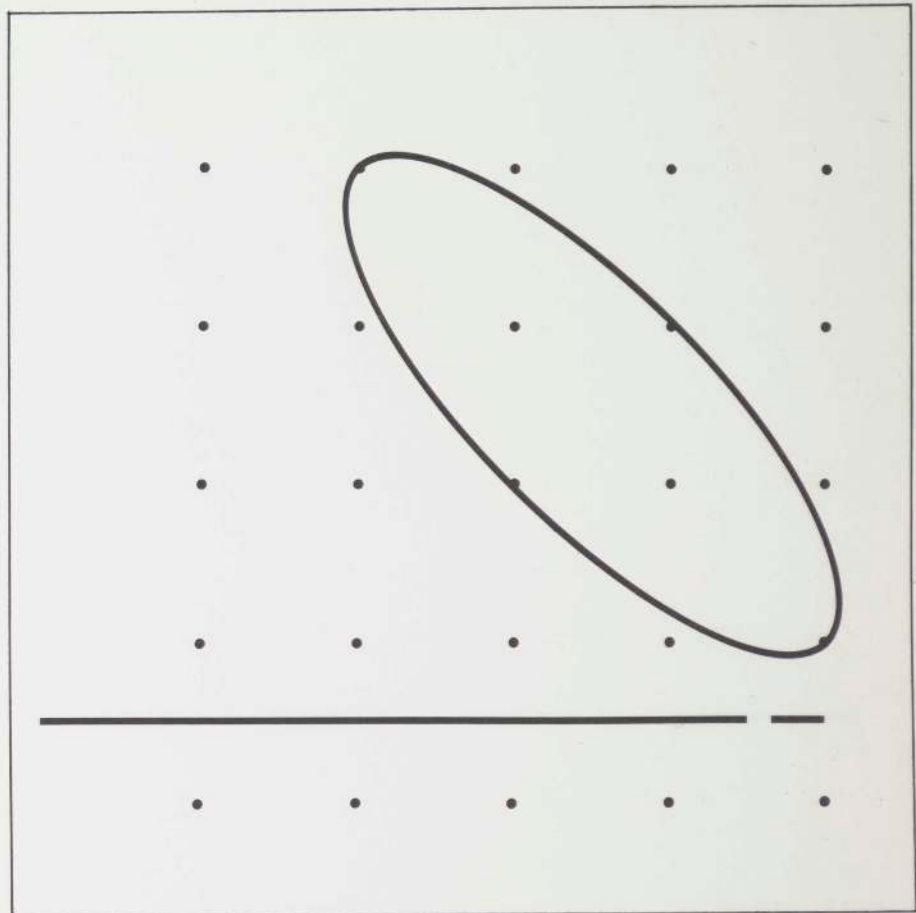
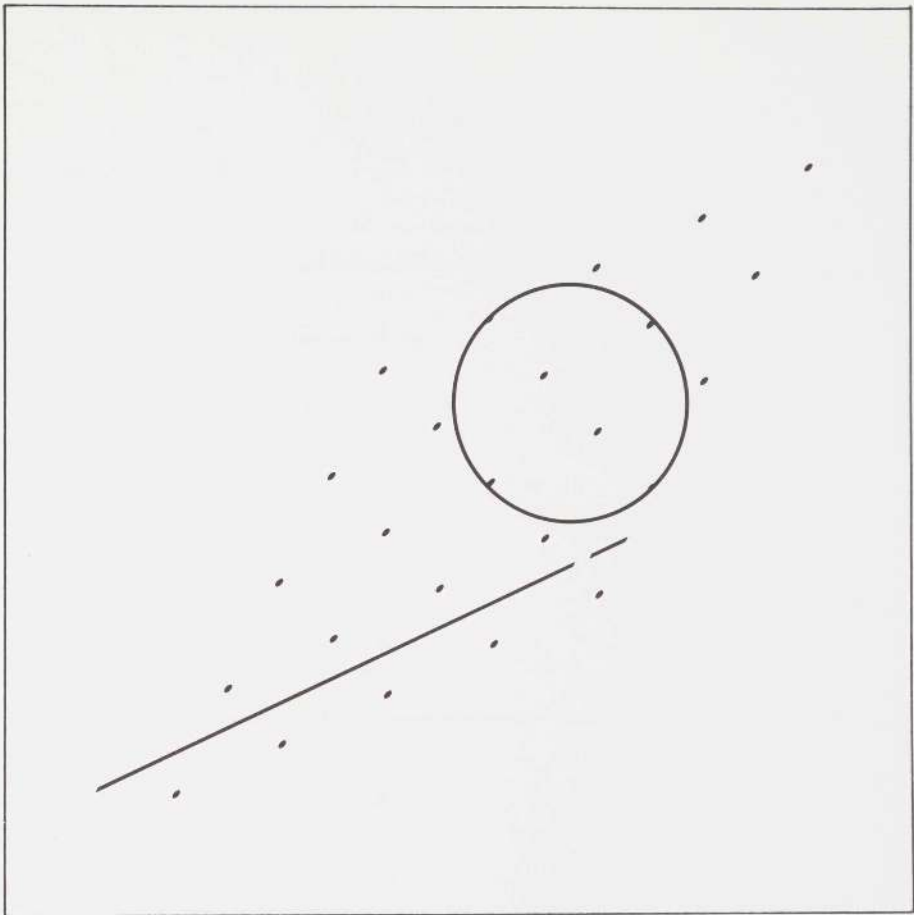

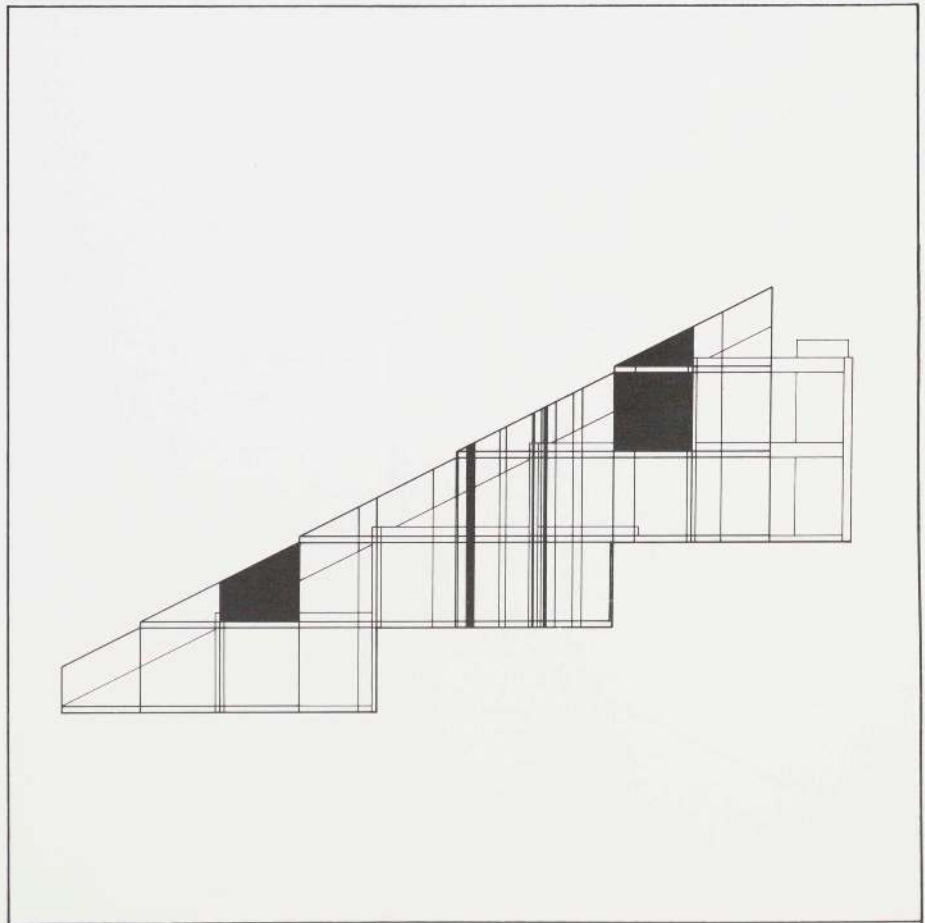
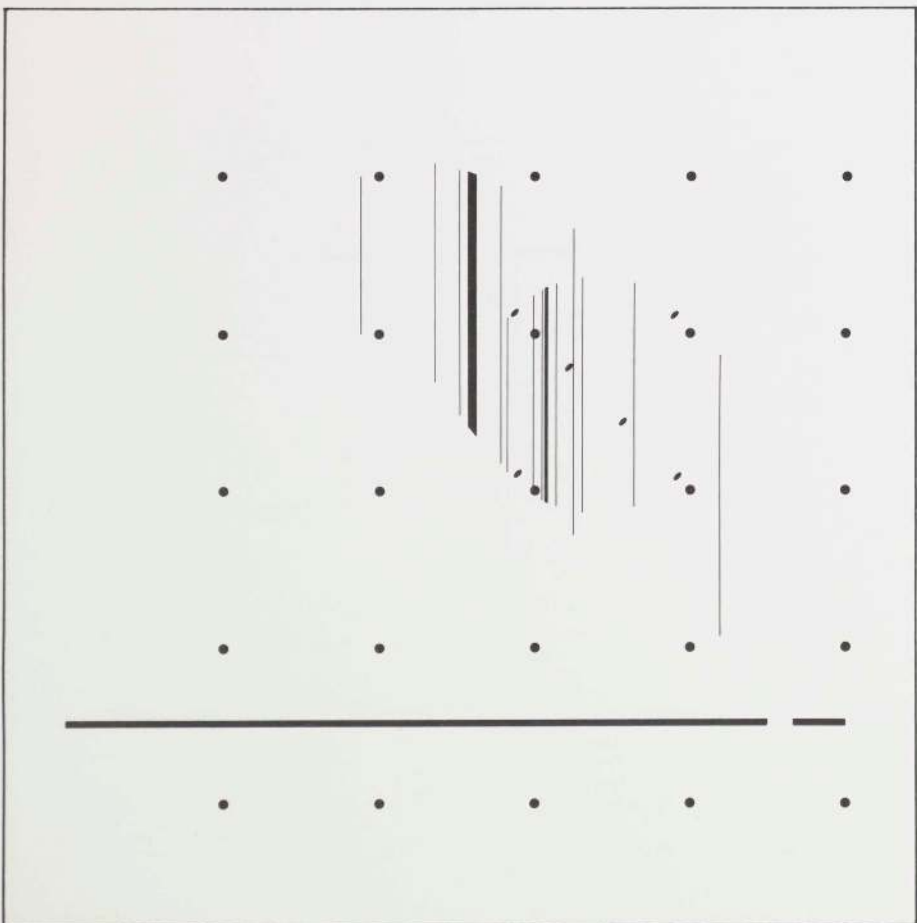
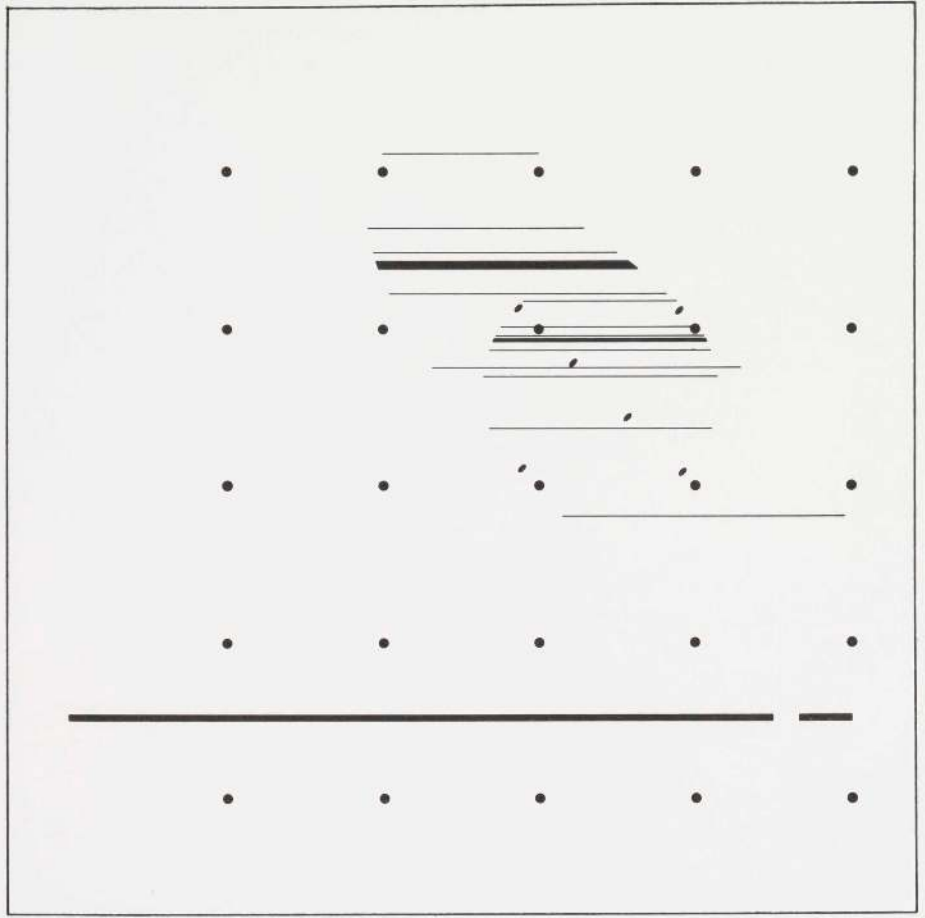
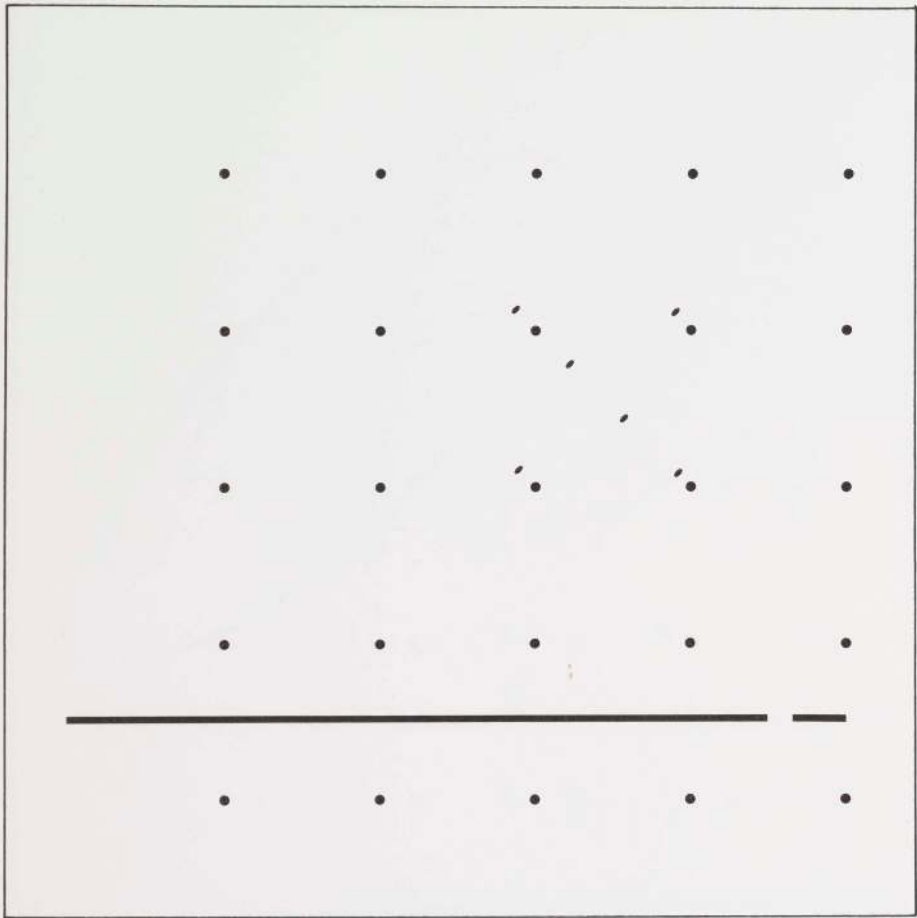



18

18

18

18

18

18

18

18

18

18

18

18

POSTSCRIPT. The model pictured on pages 295 and 300 was loaned to The Cooper Union by George E. Danforth, Director of the School of Architecture and Planning, Illinois Institute of Technology, where Mr. Rodriguez continued his work on this project. The students whose work appears in this book are listed below in alphabetic order; names are followed by dates of attendance at The Cooper Union and the numbers of the pages on which their work appears.

STUDENTS. Paul James Amatuzzo, 1964-69, 170-175/Carl Francis Anderson, 1968-present, 60-65/Edwin J. Aviles, 1964-69, 8-21/Carmi Bee, 1961-67, 84-89, 90-91/Paul Francis Bonfilio, 1962-67, 146-153/Roger Canon, 1965-70, 92-97/Theodore Michael Ceraldi, 1965-70, 106-111/Jammy Chin, 1969-present, 37/Jung Wor Chin, 1967-present, 40, 44-45/John Frederick Colamarino, 1963-69, 176-181/William John Cook, 1969-present, 43/Lewis Gary Cooper, 1965-70, 164-169/Richard Christoph Cordts, 1963-68, 190-191/Ralph Michael Desimone, 1962-67, 90-91/Michael Dolinski, 1963-68, 192-207/Steven Eliot Draper, 1970-present, 48/Frank Edwards, 1969-present, 60-65/Harold Jesse Ellis, 1965-71, 51, 52/Randy M. Epstein, 1969-present, 60-65/Steven M. Eskind, 1966-71, 118-121/Manuel I. Fernandez, 1962-68, 228-241/Roy P. Frangiamore, 1962-67, 266-271/Diana Viorica Georgescu, 1970-present, 26-27, 42/Lawrence Goldberg, 1964-69, 112-117/Harold C. Gross, 1968-present, 60-65/Werner Philip Kinkel, 1967-present, 24-25, 53/Geoffrey S. Koper, 1968-present, 60-65/Yan Korzybski, 1968-71, 272-279/Takuro Kuwabara, 1970-present, 41/Carl G. Larson, 1968-present, 60-65/Lawrence Eric Levine, 1964-69, 248-255/Diane H. Lewis, 1968-present, 57/Daniel Libeskind, 1965-70, 56, 78-83, 280-291/Peter Lung, 1965-70, 242-247/Matthew Mark MacDonald, 1969-70, 38/Richard Mangini, 1969-present, 39/James E. Miller, 1965-70, 130-135/Timothy Miller, 1970-present, 53/Julie Y. Quan, 1968-present, 28-29/Alfonso M. Rodriguez, 1962-67, 264-265, 294-301/Paul Joel Rosen, 1965-71, 72-77/Peter Saitta, 1969-present, 54-55, 66-69/Peter Richard Saltini, 1965-70, 210-225, 304-320/Kenneth A. Schiano, 1965-70, 50, 100-105/Nicholas John Schneider, 1962-67, 264-265, 302-303/William Kevin Schwartz, 1970-present, 30-33/Bartholomew Silberstang, 1962-67, 264-265/Joseph R. Simons, 1965-71, 49/Carl Stein, 1963-68, 182-189/Fred Travisano, 1962-67, 90-91, 136-145/Laurel Lovrek Travisano, 1962-67, 90-91, 122-129/George Sanford Ultan, 1963-68, 256-263/Clara Weinerth, 1967-present, 36/Lawrence Witzling, 1962-67, 154-161, 292-293.

FACULTY 1964-1971. Paul Amatuzzo / Arnold Arbeit / Louis Axelbank / Bertram Bassuk / Richard Bender / Samuel Brody / Peter Bruder / Arthur Bye / Anthony Candido / Roger Canon / Joseph D'Amelio / Richard Dattner / Lewis Davis / Anthony Eardley / Peter D. Eisenman / William C. Ellis / Ranger Farrell / Jay Fleishman / John Fowler / James I. Freed / John Hejduk / Richard Henderson / Lee F. Hodgden / Kenneth H. Kaiser / Richard D. Kaplan / Stephen Kiviat / Edward F. Knowles / Daniel Laitin / Oswaldo Lourenso / Thomas W. Luckey / Harry Mahler / Richard Meier / Carl Meinhardt / Julian J. Neski / David H. Oxman / James Stewart Polshek / John T. Roberts / David Roessler / Bernard Rothzeit / Irwin Rubin / Alan Schwartzman / Ricardo Scofidio / Sean Sculley / Ysrael Seinuk / Esmond Shaw / Robert Slutzky / Herman Spiegel / Bernard Spring / Stanley Tigerman / Fred Travisano / W. Todd Springer / Richard Stein / Edwin Stromsten / Allan Wallis / Irving Weiner / Norval White / Chester J. Wisniewski / Michael Wurmfeld.

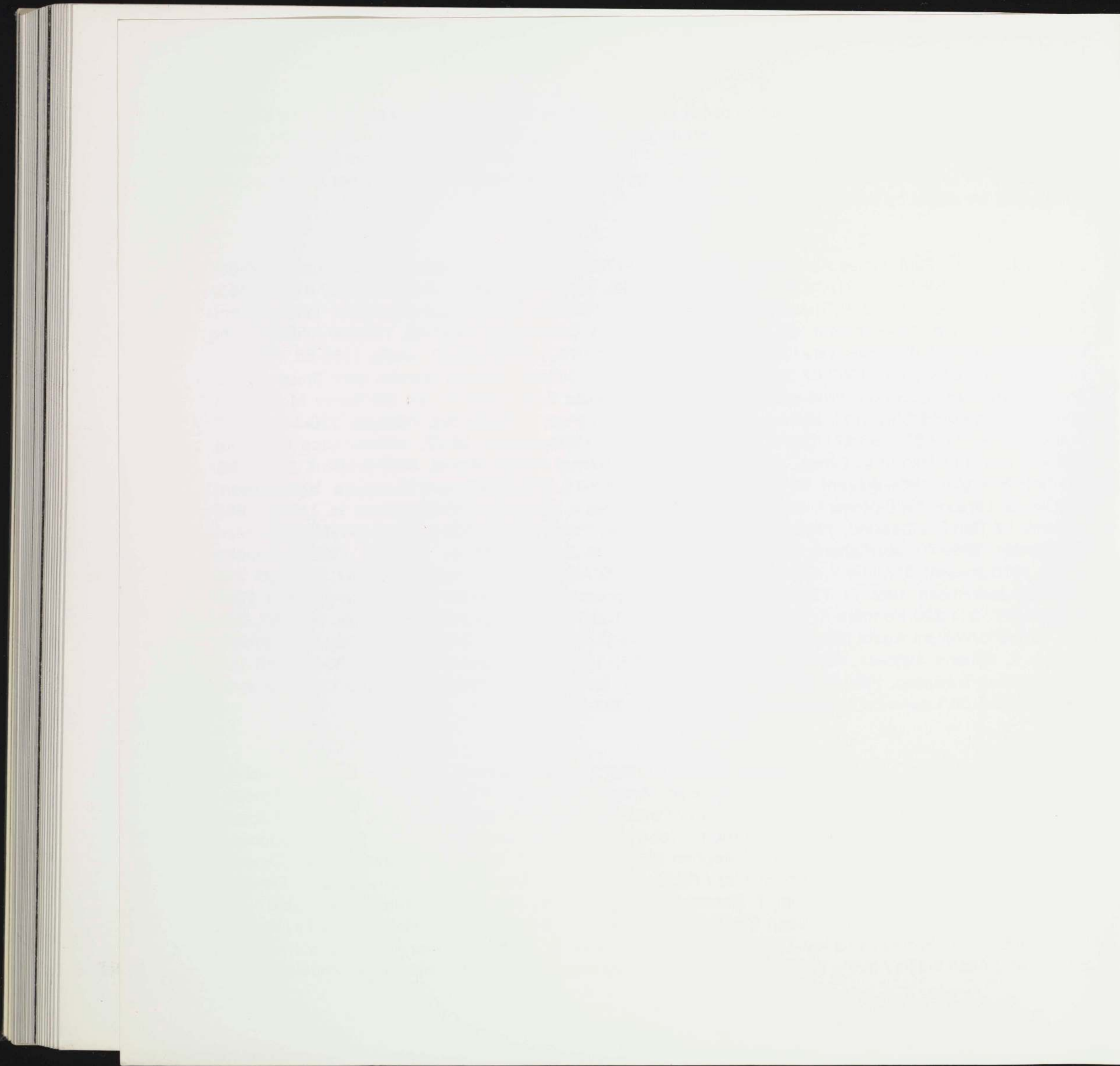

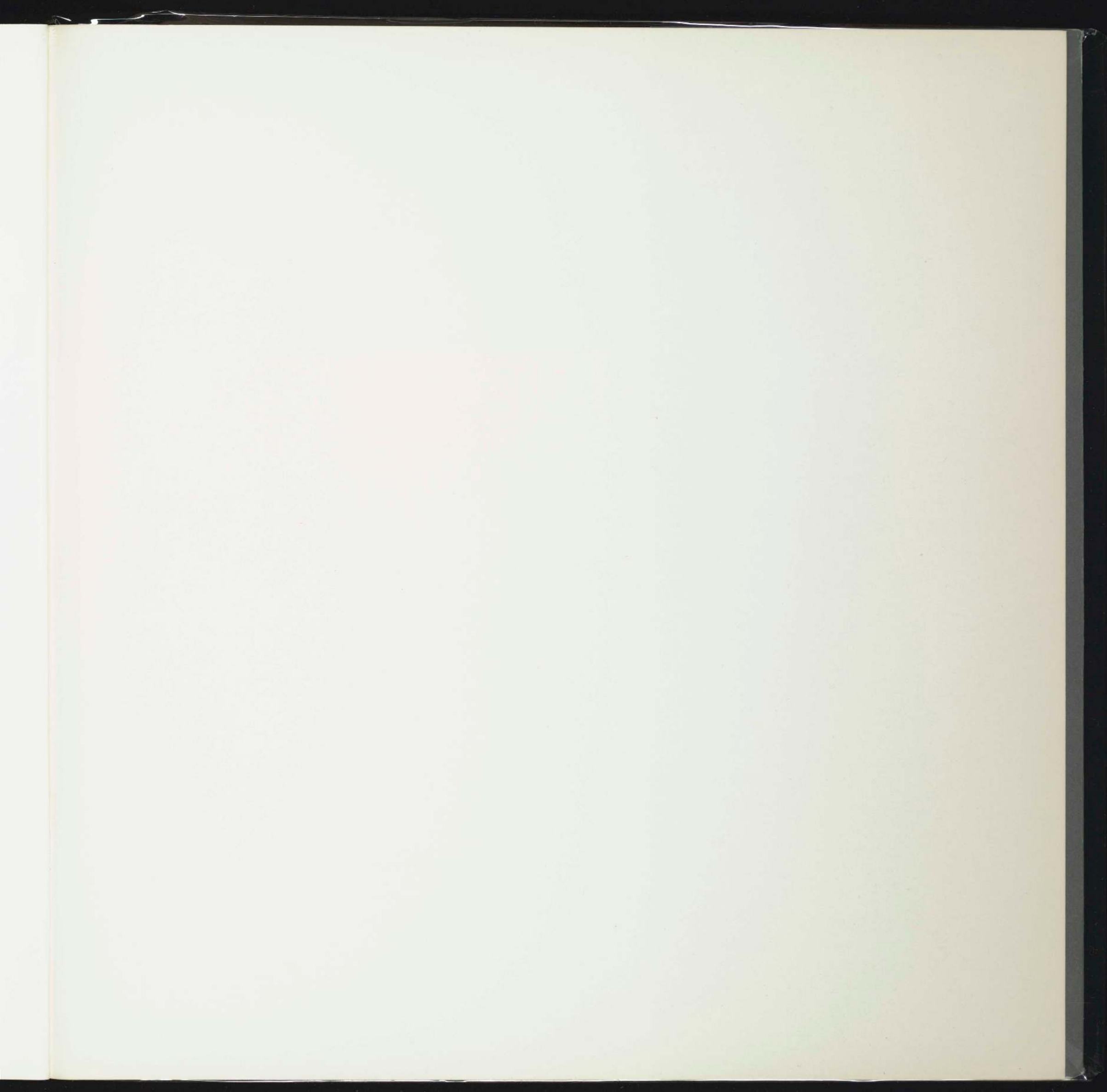

ARD
4/30/87

The Museum of Modern Art



300298971

